



ANIMAL HANDLING EQUIPMENT

ANIMAL HANDLING PRODUCTS

Dual-Access Animal Transfer Stations	<p>NU-617 NU-612 NU-610</p> 
Room to Room Pass-Through Biological Safety Cabinet	<p>NU-610</p> 
Class II Biological Safety Cabinet Procedural Station	<p>NU-629</p> 



Class II Biological Safety Cabinet
Animal Cage Changing Station

NU-602



Animal Bedding Disposal
Containment Cabinet

NU-607



Class II Biological Safety Cabinets

NU-425
NU-427
NU-430



Quality and Dependability for the Future

Animal Cage Changing Stations, Animal Bedding Disposal Cabinets, Animal Containment Enclosures, Laminar Airflow Workstations, and Class II Biological Safety Cabinets are some of the many unique, highly dependable, effective, and efficient NuAire products for use in animal facilities.

In every NuAire product you'll find brilliant and practical design, impeccable attention to detail in every phase of fabrication and assembly, outstanding value, and dependable service. This is the foundation for NuAire's international reputation, and the reason NuAire is universally recognized as the finest.



NU-607 Animal Bedding Disposal Containment Cabinet (see pg. 10).



NuAire, Inc.
Registered to ISO 9001
Certificate No. 368-98-04



NU-612 Vertical Laminar Flow Cage Changing Station

The NU-612 and NU-617 offer ISO Class 5 sterility and protection for your valuable research animals. These products also protect personnel from allergens shed by animals and bedding materials. These workstations improve productivity while offering personnel exceptional comfort and convenience through these many unique design features:

- Electric Auto-Lift to adjust work surface height at the touch of a button, or manual crank height adjustment.
- Wide 14" (356 mm) Access Opening on all sides of the station handles most standard mouse and rat cages and a wide variety of equipment.
- Extra large work area improves productivity and comfort.
- Exceptional laminar airflow—no recirculation and therefore no heat build up in the work area. Over 25 air changes per minute in the work zone.

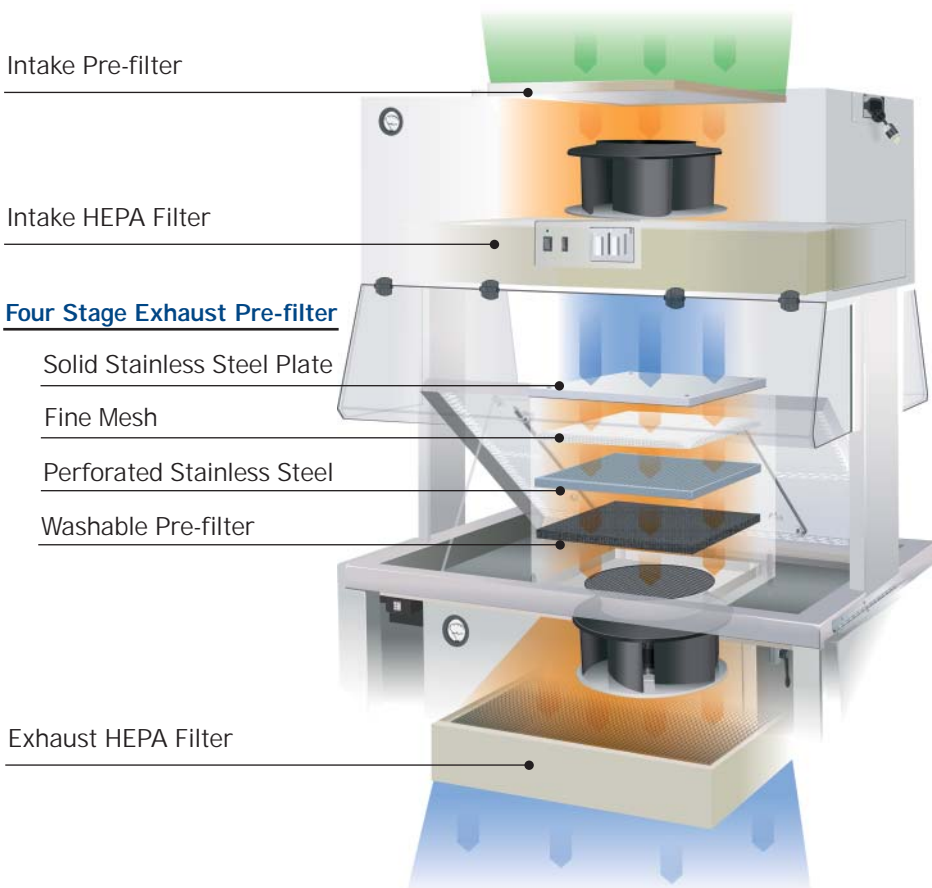

Push-Pull Airflow System

Room air passes through the pre-filter to the supply HEPA filter and is pushed downward in a uniform vertical pattern onto the work surface. Mixed air on the work surface is pulled through the work surface grills, passing through the 4-stage exhaust pre-filter and exhaust HEPA filter before being discharged back into the room.

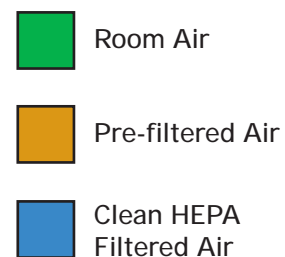

- Superb lighting from the top of the workstation provides excellent visibility.
- Flat, easy-to-clean Work Surface can be propped up with a holding rod and cleaned in place, or removed for sterilization in an autoclave.
- Pre-filter system is easy to access underneath the work surface. The system's four stage pre-filtration system above the exhaust HEPA extends filter life.
- Plenum under the work tray of welded and polished stainless steel is very easy to wipe down to maintain cleanliness.

Whether you chose the Stand-up NU-612 or the Sit-down NU-617 with spacious knee room, either AllerGard system will provide exceptional animal and personnel protection during the sensitive handling of small animals during the cage changing process.



NU-617 Vertical Laminar Flow Cage Changing / Procedure Cabinet

Specifications and Dimensions

Performance

Better than ISO Class 5 in work zone with improved allergen protection

Electrical

Model NU-612-400 / 500

Model NU-617-400 / 500

115 VAC, 60 Hz, Single Phase

Model NU-612-400E / 500E

Model NU-617-400E / 500E

230 VAC, 50 Hz, Single Phase

Note: 230 VAC models have a 10 ft. (3 m) fixed power cord.

Dimensions:

Model NU-612-400 (115 VAC)

Model NU-612-400E (230 VAC)

Overall: Inches (mm)

48 (1219) wide x 30 (762) deep x 80 (2032) to 88 (2235) high

Work Area: Inches (mm)

42⁵/₈ (1083) wide x 28¹/₄ (718) deep x 27 (686) high

Work Surface: Inches (mm)

42⁵/₈ (1083) wide x 28¹/₄ (718) depth

Model NU-612-500 (115 VAC)

Model NU-612-500E (230 VAC)

Overall: Inches (mm)

60 (1524) wide x 30 (762) deep x 80 (2032) to 88 (2235) high

Work Area: Inches (mm)

54⁵/₈ (1387) wide x 28¹/₄ (718) deep x 27 (686) high

Work Surface: Inches (mm)

54⁵/₈ (1387) wide x 28¹/₄ (718) depth

Model NU-617-400 (115 VAC)

Model NU-617-400E (230 VAC)

Overall: Inches (mm)

48 (1219) wide x 30 (762) deep x 80 (2032) to 88 (2235) high

Work Area: Inches (mm)

42⁵/₈ (1083) wide x 28¹/₄ (718) deep x 27 (686) high

Work Surface: Inches (mm)

42⁵/₈ (1083) wide x 28¹/₄ (718) depth

Model NU-617-500 (115 VAC)

Model NU-617-500E (230 VAC)

Overall: Inches (mm)

60 (1524) wide x 30 (762) deep x 80 (2032) to 88 (2235) high

Work Area: Inches (mm)

54⁵/₈ (1387) wide x 28¹/₄ (718) deep x 27 (686) high

Work Surface: Inches (mm)

54⁵/₈ (1387) wide x 28¹/₄ (718) depth



Work surface height is adjustable from 33" (838 mm) to 41" (1041 mm) in standard configuration.



The interior cross grill pattern divides the work surface into quadrants for improved cross-contamination protection from cage to cage.

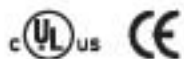

All models are designed to meet UL, CUL, CE and criteria for safety and performance.

LABGARD 610 DUAL-ACCESS CAGE CHANGING STATION



NU-610

Pass-Through Application

The LabGard 610 can be built into a wall as a clean pass-through separating room from room. The LabGard 610 provides easy access from both sides through the large window access openings.

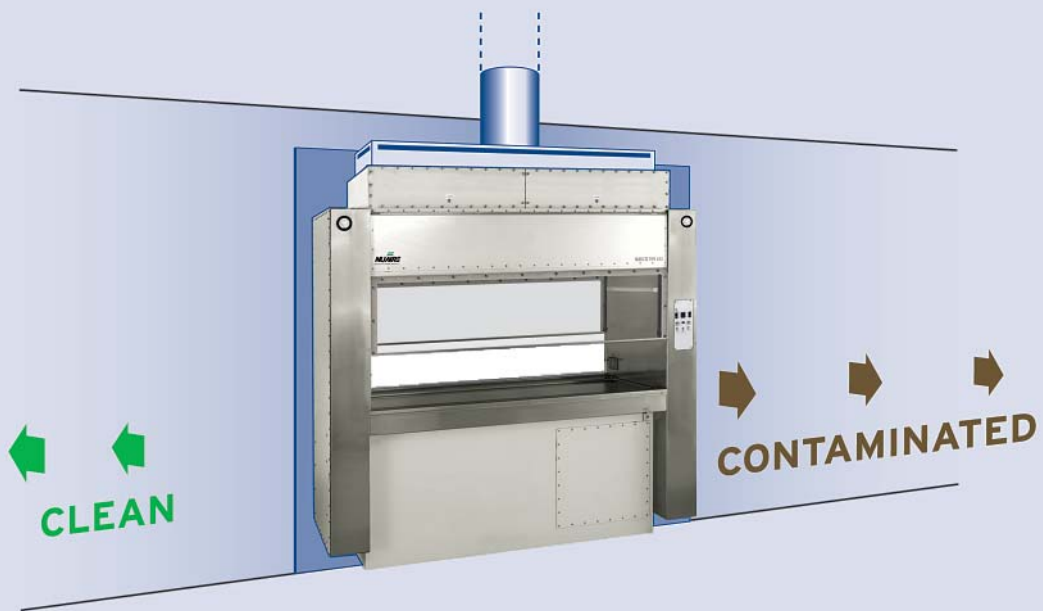

Class II, Type A2 Biological Safety Cabinet

The LabGard 610 is a Dual-Access Biological Safety Cabinet providing product, personnel and environmental protection. The LabGard 610 was especially designed to allow two laboratory technicians additional control in handling small animals during sensitive cage transfers. The Dual-Access Biological Safety Cabinet offers the following features for comfort and convenience:

- Easy access from both sides through large access opening set at an operating height of 12" (305 mm).
- Use as a mobile freestanding unit, or as a fixed pass-through from room to room.

True Laminar Airflow

- Uniform down flow velocity throughout the entire work zone.
- Minimal turbulence or cross contamination— aerosols generated within the work zone flow into the front and back work surface grills with no lateral movement.
- High Efficiency Particulate Air (HEPA) filtration at 99.99% efficient on removal of particles for supply (recirculated) and exhausted air.

HEPEX™ Zero Leak Airflow System

- All contaminated ducts, plenums, and gaskets are under negative pressure or surrounded by negative pressure to eliminate the possibility of cabinet or gasket leaks and to guard against HEPA filter failure.

Custom Design

Consult NuAire for features suitable for your laboratory requirements.

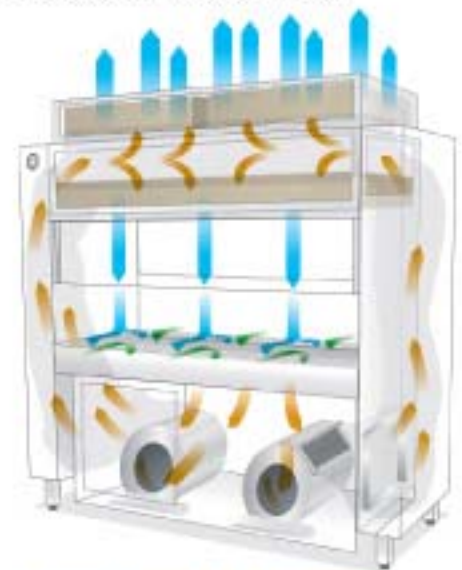

HEPEX™ Zero Leak Airflow System

- HEPA Filtered Air
- Contaminated Air
- Room Air

Specifications and Dimensions

LabGard 610 Specifications

The NU-610 is available in a 6 ft. size only

Work Access Opening

Inflow Velocity

Model NU-610-600
12" (305 mm) -
105 LFFM (0.53 m/s)

Airflow Control System

Exhaust Choke

Internal, manually operated.

Motor Speed Controller

Regulated motor/blower speed control.

HEPA Filters

Two exhaust filters, one supply filter. Efficiency rating: 99.99%

Dimensions

Model NU-610-600

Overall: 79" (2007 mm) wide x
32 1/4" (829 mm) deep x
83" (2108 mm) high

Interior: 64" (1626 mm) wide
x 28 1/4" (718 mm) deep x
25" (635 mm) high

Standard Features

- HEPEX System
- Hinged Viewing Window
- Leg Levelers
- Removable Work Tray
- Liquid Drain Valve
- Fluorescent Lights
- Two [2] Electrical Circuits w/circuit breakers
- Two [2] Duplex Outlets w/GFI
- Magnehelic Gauges
- Pre-filters

Optional Features

- Ultraviolet Lighting
- Exhaust Alarm Systems
- Additional Service Valves
- Exhaust Transition



All models are designed to meet CE criteria for safety and performance.

Comfort, Convenience Improves Productivity

The NU-629 offers Class II sterility for animals and procedure work, and bio-hazard containment for scientists and technicians. Whether standing for cage changing or sitting for procedure work, this flexible workstation is designed with many features to improve productivity:

- Electric Auto-lift to adjust work surface height at the touch of a button.
- 12" (305 mm) high access opening handles most standard mouse and rat cages and a wide variety of equipment. Sliding window opens to 19" (483 mm) for larger items.
- Large work area improves productivity and user comfort.



NU-629



The Ti j Gard 629 features a redesigned front panel to allow the user to stand closer to the unit, providing a better sight line to the work surface.



The work surface can be lifted or removed quickly without tools to allow for routine disinfection, or cleaning liquid spills.



The height of the work surface is adjustable within a 13/4" (337 mm) range from a minimum of 25 3/4" (654 mm) to a maximum of 39" (991 mm). This flexibility allows a user to sit or stand, as well as accommodating a wide range of user heights.

- Cool non-glare white lighting from the inside of the cabinet allows total visibility of the work zone and gives the user extra space in front of the cabinet.
- Easy to reach pre-filter and smooth stainless steel surfaces are easy-to-clean.
- Flat, easy-to-clean Work Surface can be propped up with a holding rod and cleaned in place, or removed for sterilization in an autoclave.

- Pre-filter is easy to access and clean; the pre-filter and drawer can be autoclaved along with the work surface.
- Large flat work tray can be easily propped up to clean the bottom spill area. A drain valve is provided to assist in the collection of liquids.
- Optional exhaust transition and flex duct, for connection to building exhaust system when working with toxic or volatile substances, do not compromise adjustability.

- Armrest to support elbows and forearms for procedure work.
- Frameless polished edge window maximizes visibility.
- Exceptional legroom underneath the work zone when seated at the cabinet.
- Centrally located control center.
- Optional Ergonomic Accessories: Elbow Rest, Footrest, Foam armrest pad, stainless steel turntable.

Effective, Flexible Features Improve Efficiency, Reliability and Maintenance

- A removable drawer in the back wall of the work zone contains a pre-filter that captures hair, dander or bedding material to prolong the life of the HEPA filters.

- Optional UV light that is interlocked with the sliding window to operate only when the window is fully closed for safety.

Ergonomic Features for Maximum Comfort and Productivity

- Electric Auto-lift to adjust work surface height so that users of any height can sit or stand at the cabinet comfortably.

Specifications and Dimensions

Specifications

LabGard 629 Class II, Type A2 Biological Safety Cabinet

Performance

NSF/ANSI 49:2002*

Electrical

115 VAC, 60 Hz, Single Phase
230 VAC, 50 Hz, Single Phase

Retracted Height:

82 1/2" (2096 mm)

Extended Height:

95 1/2" (2426 mm)

Work Surface Retracted Height:

25 3/4" (654 mm)

Work Surface Extended Height:

39" (991 mm)

Net Weight:

NU-629-400: 750 lbs. (340 kg)

NU-629-600: 880 lbs. (398 kg)

Dimensions:

Model NU-629-400

Overall (lowered): Inches (mm)

53 5/8 (1362) wide x
32 7/8 (835) deep x
82 1/2 (2096) high

Work Area: Inches (mm)

46 3/8 (1178) wide x
23 1/2 (597) deep x
28 1/2 (724) high

Work Surface: Inches (mm)

46 3/8 (1178) wide x
19 (483) deep

Model NU-629-600

Overall (lowered): Inches (mm)

77 5/8 (1971) wide x
32 7/8 (835) deep x
x 82 1/2 (2096) high

Work Area: Inches (mm)

70 3/8 (1787) wide x
23 1/2 (597) deep
x 28 1/2 (724) high

Work Surface: Inches (mm)

70 3/8 (1787) wide x
19 (483) deep



Mobility in the Animal Facility

The NU-629 can be easily lowered with the electric auto-lift and moved from one room to another through standard doorways. From an overall height of 95 1/2" (2426 mm), the cabinet can be lowered to 82 1/2" (2096 mm) for transport. Work surface height is also adjustable from 39" (991 mm) to 26" (654 mm). These height ranges can be adjusted to meet the specific needs of any facility.



All models are designed to meet UL, CUL and CE criteria for safety and performance.

*Tested to meet NSF Std. No. 49 at NuAire.

Cabinet Consists of a Stainless Steel Top and a CRS Base Forming a Monolithic Structure



NU-602

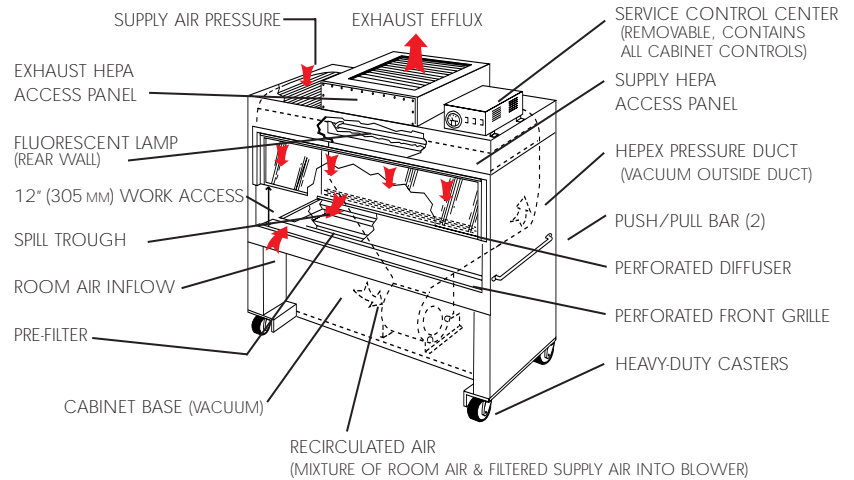

3 CONFIGURATIONS AVAILABLE

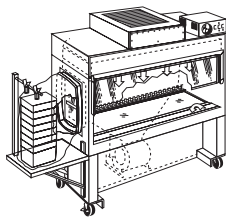

(A)

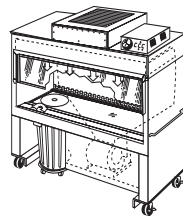

(B)

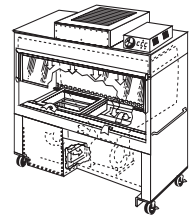

(C)

Dirty Cage Collection Option (A)

- Pass-through feature allows operator to place dirty cage from cage-changing procedure through a door in side wall and into a biohazard bag for transport to autoclave.
- This Class II Biological Safety Cabinet provides protection for user from biohazardous materials in cages, animals from cross contamination, and used cages are conveniently collected and ready for sterilization.

Refuse Disposal Option (B)

- Convenient system located below work surface allows user to easily dispose of waste materials from procedures performed within work area.
- Available on the six foot (1800 mm) model.
- Double bag disposal system includes outer bag fastened to underside of plenum with metal ring; inner bag fits snugly to the work tray to hold the refuse.
- Easy-to-manuever refuse receptacle on casters holds the bags.

Sterile Cage Delivery Option (C)

- Autoclaved, sterile cages are placed in the sterile cage delivery system where wraps are removed in clean airstream.
- Sterile cages are easily accessed by the operator through the cabinet work surface as the spring-balanced platform moves cages vertically into position.
- Delivery system maintains 12 or more mouse cages or six larger rat cages at one time.
- Sterile cages are used one at a time for continual, safer cage changing.

Class II Biological Safety Cabinet Designed to Protect

The LabGard 602 is an Animal Cage Changing Station providing personnel, product, and environmental protection during sensitive animal cage transfers. The NU-602 offers:

- Greater visibility with large 12" (305 mm) access opening
- Minimal turbulence or cross contamination-aerosols generated within the work zone flow into the front and back work surface grills with no lateral movement.
- Ease of mobility with heavy-duty casters and push-pull bars to maneuver cabinet to a convenient work location.

Ergonomic Auto-Lift

- Electronically adjustable work surface height from 31" (787 mm) to 38" (965 mm) offers the user comfort and convenience, and is versatile for multiple users.
- Prevents operator fatigue during repetitive operations.

HEPA Filtration

- High Efficiency Particulate Air (HEPA) filtration is 99.99% efficient on removal of particulates for supply (recirculated) and exhausted air.
- Automatically compensating high-capacity blower protects filter and extends filter life by providing a minimum 150% increase in static pressure across the HEPA filter.
- Adjustable internal damper and motor speed control further extend filter life.
- Pre-filters prevent large particulates from reaching HEPA filter, thus increasing HEPA filter life.

HEPEX™ Zero Leak Airflow System

The LabGard 602 is the only portable cabinet to offer this exclusive NuAire design that ensures operator safety even when cabinet has been moved from room to room.

- All contaminated ducts, plenums, and gaskets are under negative pressure or surrounded by negative pressure to eliminate possibility of cabinet or gasket leaks and to guard against HEPA failure.

LabGard 602 Specifications

Performance Specifications

The NU-602 is available in 4 ft., 5 ft. and 6 ft. sizes.
*NSF Std. No. 49

Work Access Opening

Inflow Velocity

Model NU-602-400
12" - 105 LFPM
(305 mm-0.53 m/s)

Model NU-602-500
12" - 105 LFPM
(305 mm-0.53 m/s)

Model NU-602-600
12" - 105 LFPM
(305 mm-0.53 m/s)

Airflow Control System

Exhaust Choke:

Internal, manually operated balancing damper establishes an optimum air balance between the cabinet's recirculated air system and the exhaust air system.

Motor Speed Controller:

Blower speed is regulated by a solid state triac motor voltage stabilizer/regulator.

HEPA Filters:

Two (exhaust and supply) disposable extended media, dry type filter.

Utility Connections/Installation

Duplex Outlet:

One standard, right side wall

Plant Duct Static Pressure:

0.050" - .1" H₂O Vacuum

Exhaust Flow:

NU-602-400, 407 cfm
NU-602-500, 512 cfm
NU-602-600, 617 cfm

Electrical Requirements

115 VAC, 60 Hz, Single Phase
230 VAC, 50 Hz, Single Phase

Heat Rejected:

24 to 43 BTU/min,
depending on model

Power Cord:

12/3 SJT, NGMA 5-20P plug
For 220 VAC, 50 Hz, add
suffix "E" to model number.

Standard Features

HEPEX Pressure System
Locking (Low Profile)
Swivel Casters
(Stainless Steel)

Electric Auto-lift

Stainless Steel Interior
Removable Work Tray
Liquid Drain Valve
Fluorescent Lighting
12" Access Opening (305 mm)
105 LFPM Air Barrier
(0.53 m/s)
Tempered Glass View Screen
Pre-filter
Magnehelic Gauge

Optional Features

Ultraviolet Light
Ground Fault Interrupter
Petcocks
Three Optional Configurations

Dimensions

Retracted Height:

All Models: 77" (1956 mm)

Extended Height:

All Models: 84" (2134 mm)



All models are designed to meet UL, CUL, and CE criteria for safety and performance.

*Tested to meet NSF Std. No. 49 at NuAire.

Model NU-602-400

Overall: Inches (mm)

50½ (1283) wide x
31¼ (806) deep x
77 (1956) high

Work Area: Inches (mm)

46½ (1181) wide x
24½ (622) deep x
26½ (673) high

Model NU-602-500

Overall: Inches (mm)

62½ (1588) wide x
31¼ (806) deep x
77 (1956) high

Work Area: Inches (mm)

58½ (1486) wide x
24½ (622) deep x
26½ (673) high

Model NU-602-600

Overall: Inches (mm)

74½ (1892) wide x
31¼ (806) deep x
77 (1956) high

Work Area: Inches (mm)

70½ (1791) wide x
24½ (622) deep x
26½ (1956) high

Safe and Dependable Animal Bedding Disposal Containment Cabinet

The AllerGard 607 Class I Animal Bedding Disposal Containment Cabinet offers the Animal Research Professional the opportunity to work with the first cabinet of its kind. The 607 minimizes the risk of exposure to allergens and animal infections for the technician handling low to moderate risk material.

Cleaning cages and handling infested bedding is an unpleasant task at best, but the AllerGard 607 makes it easier, safer and more efficient.



NU-607

CONFIGURATION FLEXIBILITY



The AllerGard 607 is available with three different chutes to handle small and large animal cages.

Portably convenient

- Rugged casters with locking brakes make the NU-607 portable, yet secure.
- Cabinet fits through standard doorways.
- Push-pull bars on each side of the cabinet make it easy to maneuver into the most convenient work location and lock into place.
- Heavy-duty 22 gallon (83 liter) waste receptacle has its own platform with casters to aid movement with the cabinet when receptacle is full.

Optimum Protection from Controlled Air Inflow

- Personnel protection provided by uniform air barrier across front access.
- 14" (356 mm) access opening.
- Inflow velocity of 100 FPM (0.5 m/s) prevents migration of contaminants from work zone into the room.

Visibility and Light-Clearly Superior

- Clear visibility of work area from clear acrylic side panels and polycarbonate front window.
- Well-lit work area provided by externally mounted fluorescent light.
- Easily accessible work surface through cabinet's full width work access opening.

Built-in Safety from Dual Alarm Electronic Airflow Monitor

- Electronic airflow monitor ensures adequate airflow through work access opening.
- Audiovisual alarm warns technician if airflow falls below minimum set point.

Dependable Efficiency from Better Filtration

- Air enters work zone from laboratory and is drawn up under negative pressure through NuAire's exclusive three-filter design.
- A pre-filter preserves the life of the HEPA filter.
- A 99.99% efficient HEPA filter removes particulates.
- A sorbent, activated charcoal filter downstream from the HEPA filter removes odors before air exits from top rear of the cabinet.

Simplified Maintenance for Increased Safety over a Longer Operational Life

- Easily accessible service compartments are hinged for convenience.
- No requirement for special tools to perform routine Maintenance.

AllerGard 607 Specifications

The NU-607 is available in a single 4 ft. size.

Standard Features

- Baked White Urethane Exterior Filter Module
- Fluorescent Light (Outside Work Zone)
- Enclosed All Stainless Base Cabinet
- Activated Sorbent Filter (Odor Removal)
- HEPA Filter Exhaust, 99.99% on 0.3 micron
- 100 FPM Air Barrier-14" (356 mm) access opening
- Airflow (Alarm) Monitor
- Stainless Steel Work Surface
- Top Access Bag Installation
- Large Castered Waste Receptacle
- Castered Base Cabinet (With Doors)
- Front Filter Removal
- Small Animal Bedding Disposal Chute

- Pre-filter
- Hinged Viewing Window
- Clear ½" (13 mm) Acrylic Side Panels
- Automatic Triac for Line Voltage Stability
- Instrument Panel at Eye Level
- Bang Bar

Electrical Requirements

- 115 VAC, 60 Hz, 5 amps
- Heat Rejected: 15 BTU/min
- Power Cord: 14/3 SJT, NEMA 5-15P plug
- For 220 VAC, 50 Hz, add suffix "E" to model no.

Optional Features

- Spare Disposal Bags
- Double Square Chute Design
- Spare Disposal Can
- Large Animal Single Square Chute
- Replacement Filters

Model NU-607-400

Dimensions

Overall: Inches (mm)

50 (1270 mm) wide x
29 (737 mm) deep x
79 (2007 mm) high

Work Area: Inches (mm)

43¼ (1099) wide x
27½ (699) deep x
24 (610) high





NU-125-SPEC

NuAire has developed a custom enclosure to fit over the top of Garb-el disposal systems used in animal facilities to dispose of non-hazardous bedding materials. The system is a self-contained, stand-alone Class I Safety Enclosure that operates independently of the waste system, and includes the following features:

- Low Profile 16 $\frac{1}{4}$ " (413 mm) filter module with spacious 24" (610 mm) access opening for dumping soiled cages,
- Removable pre-filter protects the 3" (76 mm) thick HEPA filter.
- Personnel protection from allergens and other aerosolized particulates generated in the dumping process by a 100 FPM (0.5 m/s) air barrier across the access opening.

- Well-lit work area provided by fluorescent light mounted on the back wall of the enclosure.
- HEPA module mounted on a 16 gauge stainless steel wrap that is bolted through a gasket to the top of the Garb-el disposal.
- Optional charcoal filter controls odors from bedding materials.
- Pre-assembled safety enclosure with Garb-el disposal or retrofit safety enclosures to Garb-el systems in the field.

NU-125-SPEC: Enclosure for Garb-el Disposal System:

Overall Dimensions:

81 $\frac{1}{2}$ " (2064 mm) High x
47 $\frac{5}{8}$ " (1210 mm) Wide x
23 $\frac{1}{2}$ " (587 mm) Deep

NuAire Enclosure Only:

46 $\frac{1}{2}$ " (1181 mm) High x
47 $\frac{5}{8}$ " (1210 mm) Wide x
23 $\frac{1}{2}$ " (587 mm) Deep

Electrical:

120V 60 Hz, 9 amps,
Single Phase.

Garb-el Disposal System Only:

34 $\frac{3}{4}$ " (2064 mm) High x
47 $\frac{5}{8}$ " (1210 mm) Wide x
23 $\frac{1}{2}$ " (587 mm) Deep

Electrical:

208/240V, 3-Phase



The NuAire NU-125-Spec enclosure provides personnel protection from allergens and other aerosolized particulates generated in the dumping process, by a 100 FPM (0.5 m/s) air barrier across the 24" (610 mm) access of the enclosure.

CUSTOM BEDDING DUMP STATION

NuAire has developed many custom enclosures designed to protect personnel from allergens and odors associated with dumping procedures in animal facilities.

From small requirements for a limited number of cages to high volume facilities, NuAire can offer a safety enclosure tailored to meet the needs of nearly every animal resource facility.

The Dual Dump Station (pictured) is an enclosure designed for a high-volume facility. Characteristics of this custom station include:

- 16 gauge welded stainless steel design.
- Ergonomic adjustable height base stand allows users to adjust to comfortable work-surface height.
- Easily cleanable work zone is barrier and crevice free.
- Large front access opening protected by 100 FPM (0.5 m/s) Class I air barrier ensures that allergens and aerosolized particulates are retained by HEPA filter.
- Optional charcoal filter controls odors from bedding materials, or enclosure may be exhausted from the building through an optional thimble-type transition on top of the enclosure.

Where mobility is an issue, consider the NU-607 bedding disposal cabinet. If containment of biohazardous bedding is required, the NU-602 can be modified for refuse disposal.



NU-607-SPEC Custom Bedding Disposal Station:

Dimensions:

Height: Adjustable 77"-85" (1956 mm - 2159 mm)

Width: 80" (2032 mm)

Depth: 51½" (1308 mm)

Electrical:

120V, 60 Hz

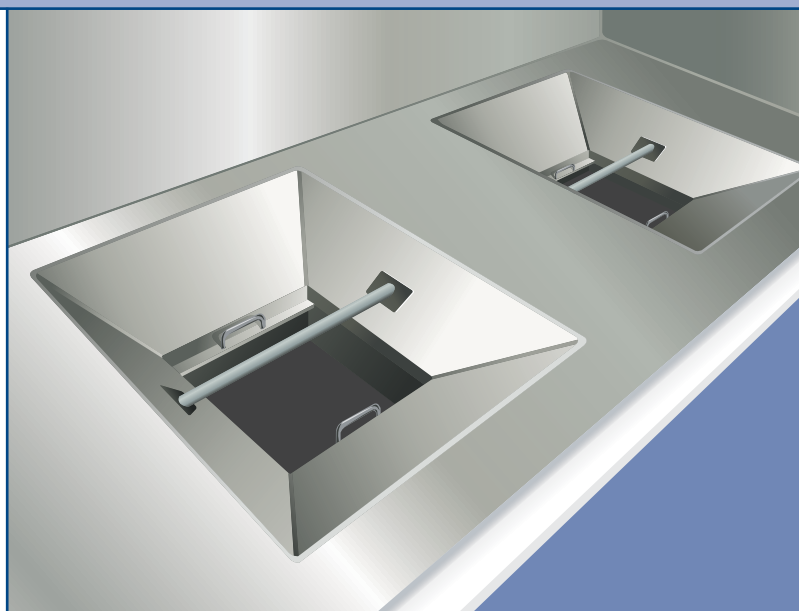

This unit was specially designed with two 16 gauge welded stainless steel dump chutes, which allows two users to work side-by-side.

LABGARD 400 SERIES BIOLOGICAL SAFETY CABINETS



NU-425



NU-427



NU-430



LabGard 425 Class II, Type A2

NuAire's LabGard 425 Biological Safety Cabinet is a gastight model which prevents cross contamination of biologicals and protects the user-technician from exposure to hazardous agents within the work zone.

For better personnel and product protection, dependability, ease of operation, configuration and flexibility with less maintenance, the LabGard 425 is the clear choice.

LabGard 427 Class II, Type B1

The LabGard 427 is a Class II, Type B1, Laminar Flow Biological Safety Cabinet offering a monolithic, low profile design. This new generation of design incorporates NuAire's exclusive High Efficiency Particulate Air (HEPA) filtration within the proprietary NuAire Flow System.

The improved design means increased personnel protection, improved product safety, simpler maintenance, lower life cycle cost and greater dependability.

LabGard 430 Class II, Type B2

The LabGard 430 Laminar Flow Biological Safety Fume Cabinet offers superior combined performance in a gastight, 100% Total Exhaust cabinet which operates as a biological safety cabinet or fumehood.

A unique combination of True Laminar Airflow, Highest Quality HEPA filters, and the HEPEX Zero Leak Airflow Filtration System delivers a level of quality construction, reliability and value unequaled anywhere.

LabGard 425 Class II, Type A2

Performance Specifications

NSF/ANSI 49:2002

Models, Work Access Opening and Inflow Velocity

Model NU-425-200

8 inches, 105 LFPM

Model NU-425-300

8 inches, 105 LFPM

Model NU-425-400

8 or 10 inches, 105 LFPM

Model NU-425-600

8 or 10 inches, 105 LFPM

Standard Features

- HEPEX Zero Leak Airflow System
- Single Piece Stainless Steel Cabinet
- External Fluorescent Lighting
- Removable Work Tray
- Sliding Glass View Screen
- Front Filter Removal
- Interior Duplex Outlet
- Removable Service Control Center
- Magnahelic Pressure Gauge
- Motor Voltage Stabilizer/Regulator

LabGard 427 Class II, Type B1

Performance Specifications

NSF/ANSI 49:2002

Models, Work Access Opening and Inflow Velocity

Model NU-427-400

8 inches, 105 LFPM

Model NU-427-600

8 inches, 105 LFPM

Standard Features

- HEPEX Zero Leak Airflow System
- Single Piece Stainless Steel Cabinet
- External Fluorescent Lighting
- Removable Work Tray
- Sliding Glass View Screen
- Front Filter Removal
- External Duplex Outlet
- Integral Exhaust HEPA filter
- Electronic Exhaust Flow Warning System
- Electronic Exhaust Interlock System

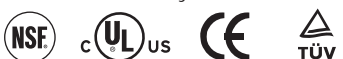

All models are designed to meet UL, CUL, CE and TÜV criteria for safety and performance.

LabGard 430 Class II, Type B2

Performance Specifications

NSF/ANSI 49:2002

Models, Work Access Opening and Inflow Velocity

Model NU-430-400

8 inches, 105 LFPM

Model NU-430-600

8 inches, 105 LFPM

Standard Features

- HEPEX Zero Leak Airflow System
- Single Piece Stainless Steel Cabinet
- External Fluorescent Lighting
- Removable Work Tray
- Sliding Glass View Screen
- Front Filter Removal
- External Duplex Outlet
- Digital Electronic Safety System
- Exhaust Interlock Alarm
- Low Exhaust Alarm



-86° Glacier Blue



-86° Chest Freezer



NU-5500



NU-8700

Ultralow Temperature Freezers

NuAire Ultralow Temperature Freezers combine quality and performance to meet your requirements for research, clinical and industrial applications. Fully utilizing the most advanced compressor technology with state-of-the-art electronic technology and CFC-Free Refrigerants, the Ultralow Freezers from NuAire deliver a level of quality, reliability, and value unequaled anywhere.

AutoFlow Incubators

NuAire leads the world with the introduction of the innovative family of AutoFlow Incubators. Today's laboratory professional requires a higher level of performance and dependability for optimum growth conditions. NuAire meets and exceeds the demand for a higher level of performance and dependability with the AutoFlow Incubators—designed with the most advanced features available for research and laboratory work using in vitro models of in vivo environments.

ACCESSORIES



[A]



[B]



[C]



[D]

Airflow Sentry System [A]

Can be used for applications requiring monitoring the mass flow of an airstream for minimum acceptable airflow set points. System automatically warns of low airflow conditions by audio and visual means.

Model No.
NU-AIN-315BSC;
NU-AIN-350CEM; NU-956

Stainless Steel Butterfly Valves [B]

Design features all stainless steel construction and silicon gasketing for high reliability. Valves can be operated manually or actuation motors can be added for automatic operation.

Model No.
NU-940; NU-951

Portable Ultraviolet Light [C]

Germicidal ultraviolet light is primarily intended for the destruction of surface bacteria and other microorganisms in the air or on exposed surfaces. Available in two and four foot sizes. 115 VAC, 60 Hz.

Model No.
NU-959-200; NU-959-400

Exhaust Transitions [D]

Exhaust air duct transitions enable Class I, II Biological Safety Cabinets as well as the NU-607 Animal Bedding Disposal Cabinet to be connected to an in-house exhaust system. Two transition configurations are available, low-profile and thimble. NuAire's exhaust transitions can be easily installed for gastight or air-gap configurations.

Model No.
NU-927; NU-928; NU-929

TESTING

Full factory testing is your assurance of reliability in the laboratory. Each NuAire product is thoroughly inspected in our factory prior to final shipment, and that's just the final step in a rigorous system of quality control – from superior designs and materials, to finished product and final testing for certified performance. Whenever quality cannot be fully assessed in final assembled form, products are thoroughly inspected during sub-assembly fabrication.

WARRANTY

We continually believe our customers deserve the best equipment available in terms of performance, safety, and service. We have implemented this objective by offering our customers the strongest warranty in the market. NUAIRE wants you to have the best. You have purchased the best... now we want you to have a warranty that is the best. We want you to know that your confidence is well placed in NUAIRE products.

CUSTOMER SALES AND SERVICE

Our customers say the nicest things about us. NUAIRE has redefined customer service, as exemplified by our expertly trained staff who have happily created strong relationships with our customers. NUAIRE service extends throughout the world. We extend to you, our valued customer, a service concept unique in the market.

"we give you consistently the best we have to offer."

For product selection assistance, please contact Customer Service at **1.800.328.3352**.



www.nuaire.com

WITH NUAIRE YOU KNOW



2100 Fernbrook Lane
Plymouth, MN 55447
U.S.A.
Phone: 763.553.1270
Fax: 763.553.0459
1.800.328.3352

www.nuaire.com



COMFORT

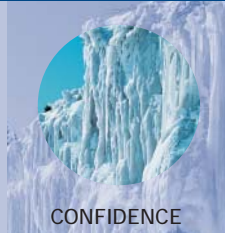

CONFIDENCE



CONTROL

Process 9-1068P Rev. 6 7/05