

GENERAL NOTES:

1. UNIT WEIGHT: 950 lb
2. SHIPPING WEIGHT: 1070 lb
3. CRATED EXTERIOR DIMENSIONS:
57" [1448] L X 63" [1600] W X 80" [2032] H
4. HEAT REJECTION TO ATMOSPHERE:
PEAK HEAT REJECTION = 4500 BTU
AVERAGE HEAT REJECTION = 3500 BTU
5. AMBIENT OPERATING CONDITION:
TEMPERATURE = 10-30° C
RELATIVE HUMIDITY = SEE MANUAL
6. (3) SHELVES INCLUDED:
SHELF CAPACITY: 120 lb EACH
ADJUSTABLE BY 1" INCREMENTS

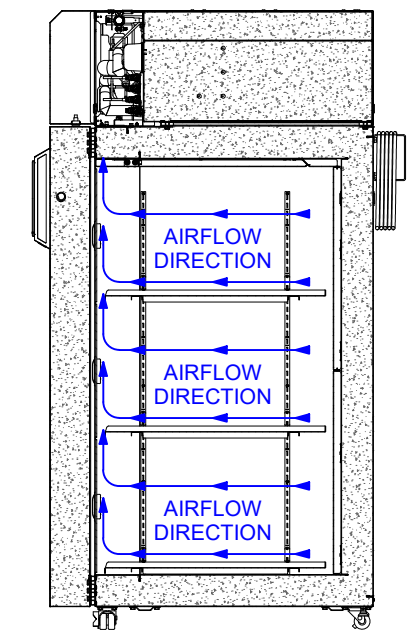
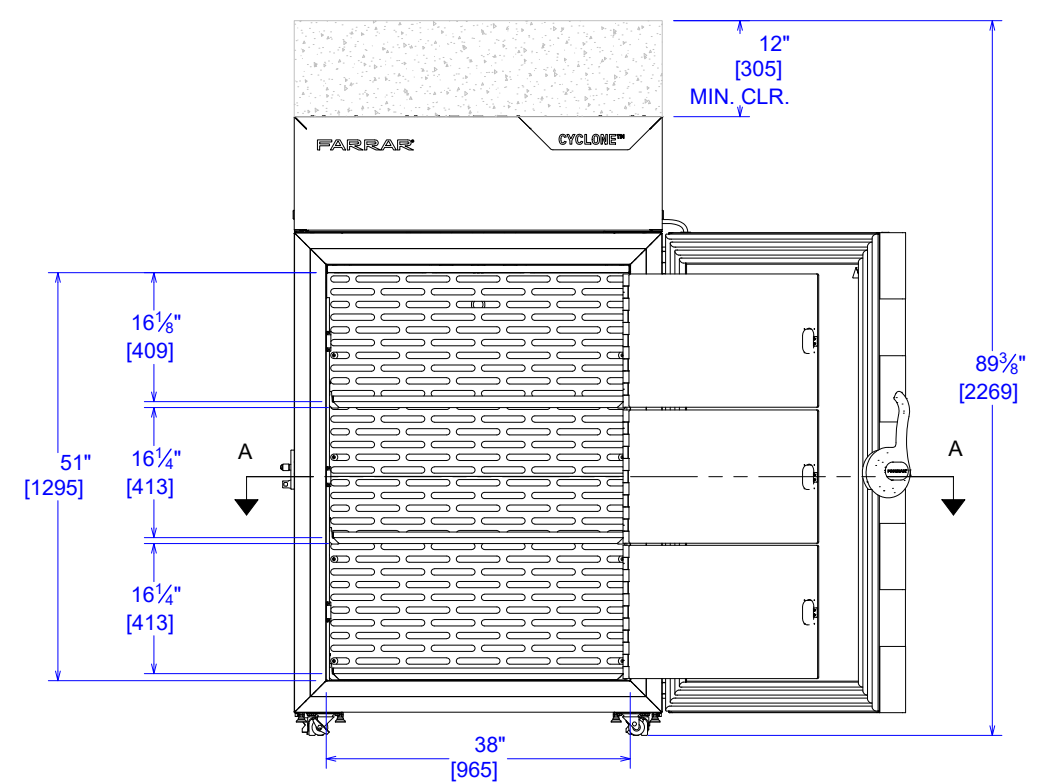
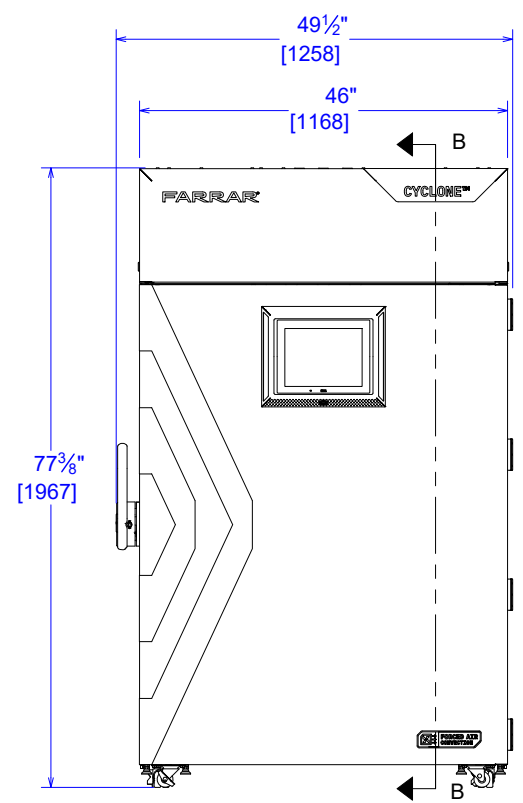
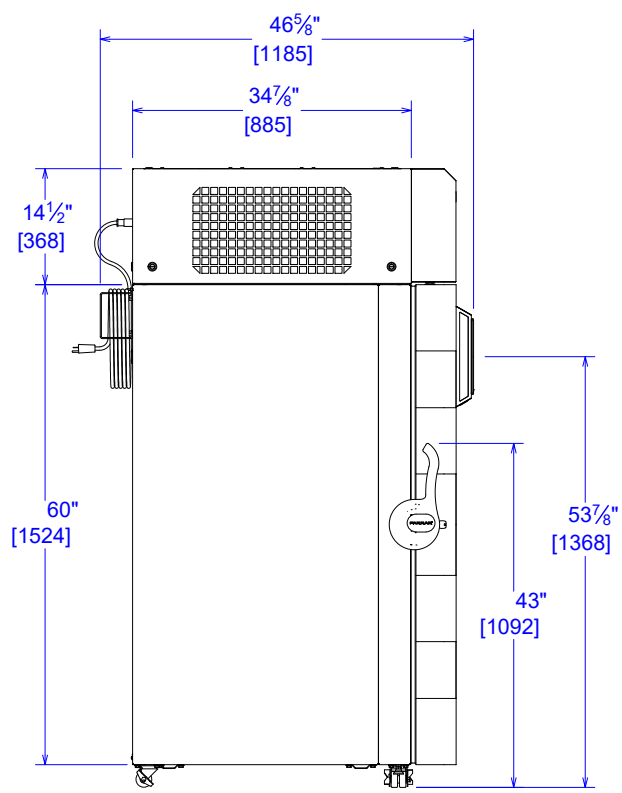
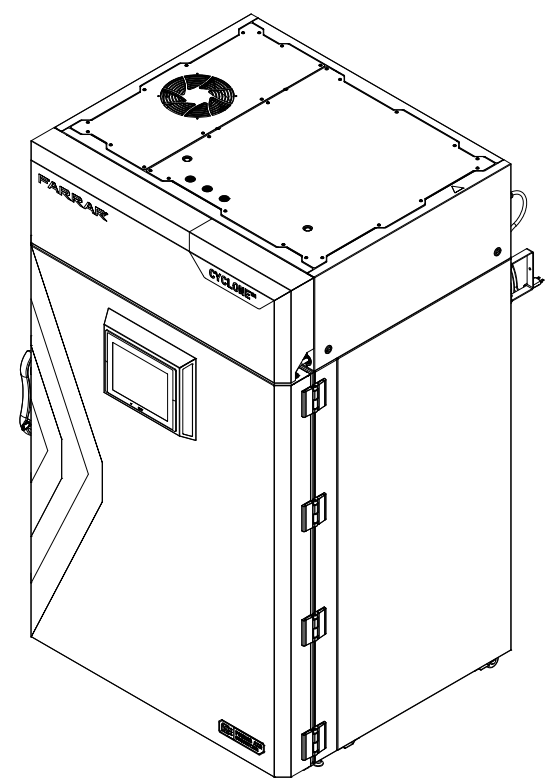
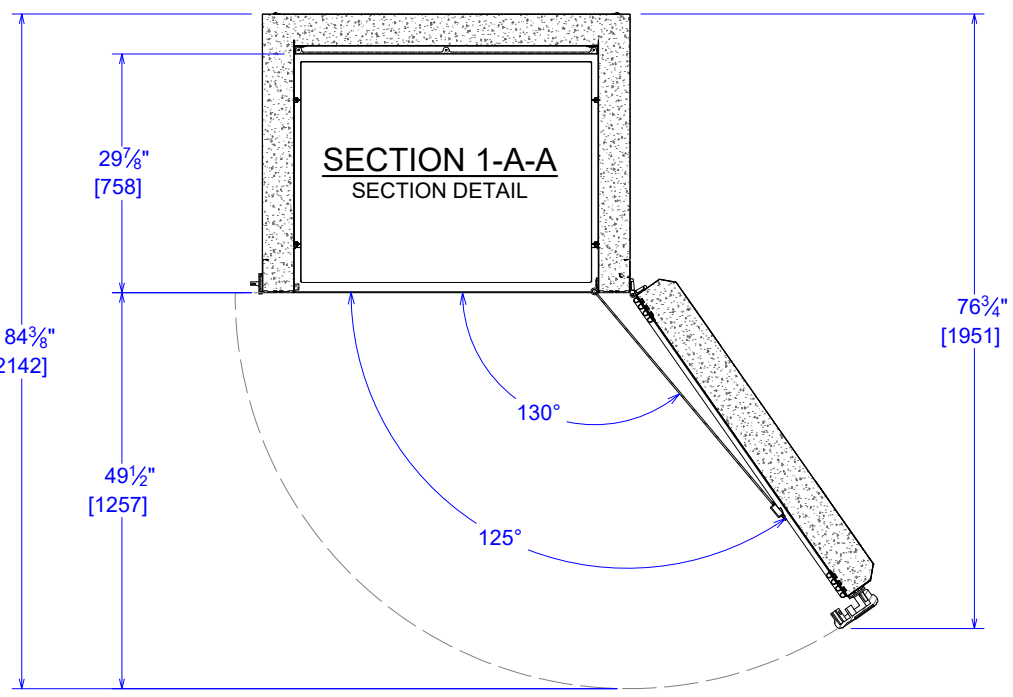
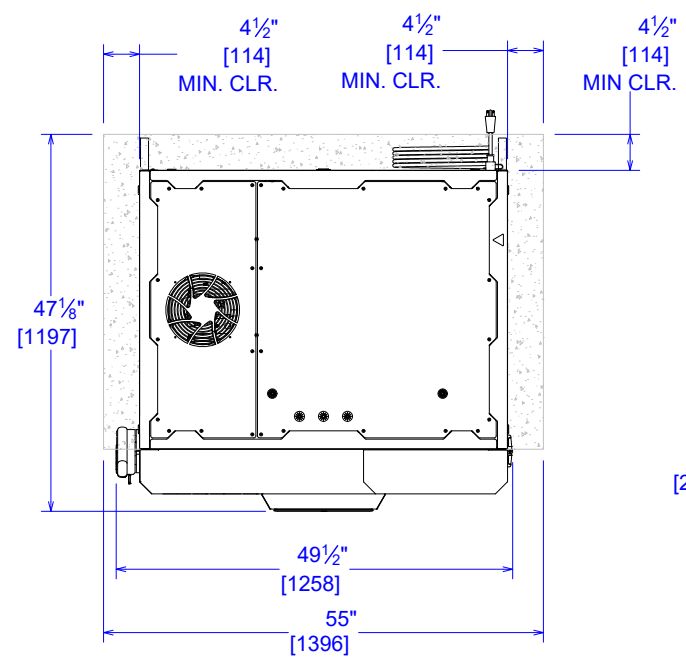

POWER REQUIREMENTS

TOLERANCES

THIS DOCUMENT CONTAINS PROPRIETARY INFORMATION AND SUCH IS NOT TO BE DISCLOSED TO OTHERS FOR ANY PURPOSE OR USED FOR MANUFACTURING PURPOSES WITHOUT THE WRITTEN PERMISSION OF TRANE TECHNOLOGIES.

SPECIFICATIONS, CYCLONE

- .x ±.1
- .xx ±.03
- .xxx ±.015
- .xxxx ±.0005
- ANGLE ±1°
- FRACTIONAL ±1/4
- DIMENSIONS ARE IN INCHES UNLESS OTHERWISE SPECIFIED



30765 OH-7 | MARIETTA, OH | 45750 | ph. 740.374.8300 | fx. 740.374.8310

SIZE B	DWG NO SPEC SHEET, CYCLONE	REV 1
------------------	--------------------------------------	-----------------

ELECTRICAL REQUIREMENTS	BREAKER SIZE	CORD
-------------------------	--------------	------

220-240 VAC - SINGLE PHASE - 50/60 HZ 10.13 FLA: 2 WIRES + GND	15A	NORTH AMERICA - C19 NEMA 6-15 EU/WORLD - C19 CEE 7/7 (SCHUKO) UNITED KINGDOM - BS1363 (UK/SASO)
---	-----	---

DRAWN BY B. IRWIN	DRAWN DATE 3/21/2025
APPROVED BY S. MASIELLA	APPROVAL DATE 3/21/2025
REFERENCE N/A	SCALE 1 / 24
SHEET 1 OF 1	