

Ultra Low Temperature Freezer User Manual L2X-3-ULT85

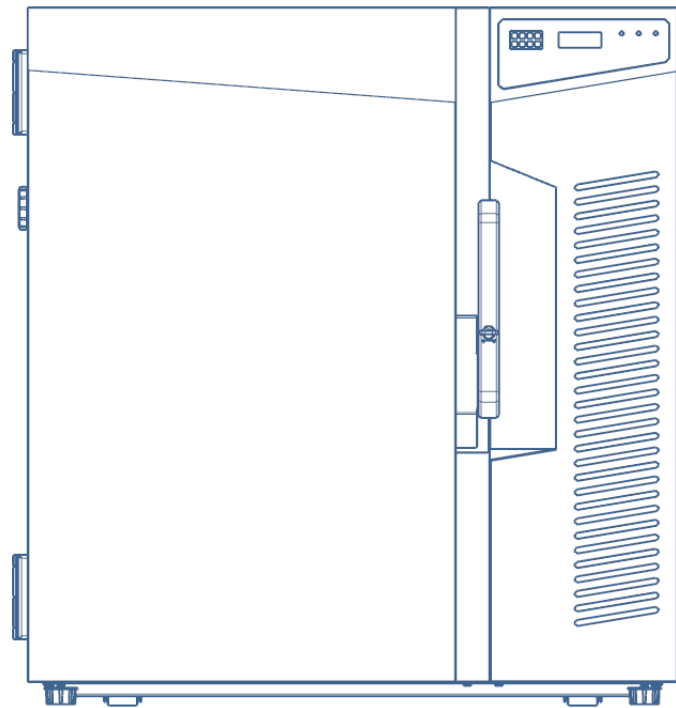

- Please read this manual carefully before use.
- The appearance of the product is subject to the actual product.
- In case of product technology or software upgrade, without prior notice.

Ultra Low Temperature Freezer

.

This manual covers below models:

L2X-3-ULT85

Read before using this equipment.

This product is intended for use by trained personnel only.



Contents

Precautions for Safe Operation.....	2
Usage Precautions	6
Product Installation	7
■ Installation environment.....	7
■ Installation site	7
■ Preparation before use	8
■ Power on the first time.....	9
■ Operation after a power outage	10
Product Description	11
■ Freezer Components.....	11
■ Control panel.....	11
Usage.....	12
■ Check the ambient temperature	12
■ Mute the alarm sound.....	12
■ Key lock	12
■ Key unlock.....	12
■ Parameter setting	12
■ USB data export.....	13
Display and Operational Anomaly Warnings	13
■ Remote alarm terminal	14
Cleaning and Maintenance	15
■ Cleaning of components.....	15
■ Cleaning the freezer	15
■ Clean the condenser filter.....	16
■ Defrosting on the inner wall	16
■ Battery maintenance	16
■ Scrapping of the freezer	17
Recycle of Rechargeable Battery	18
■ Location of the battery	18
■ Removal of the battery	18
Trouble Shooting	19
Freezer principle and circuit diagram	20
■ Freezer schematic diagram	20
■ Circuit diagram	21
Specification and technical data	22
■ Packing list.....	22

Precautions for Safe Operation

Please read this manual for safe operation and use of this product.

■ Safety Labels Safety Precautions



Hazard point



Electric shock

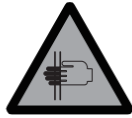

Risk of crushing



Highly flammable substances



Warning
Low temperature



Grounding

■ Precautions for safe operation



Warning

Failure to observe WARNING signs could result in a hazard to personnel possibly resulting in serious injury or death.



Caution

Failure to observe CAUTION signs could result in injury to personnel and damage to the unit and associated property.



Actions or operations which are prohibited



Actions or operations which must be followed

❗ When CO₂/LN₂ backup is activated, the location place must be well ventilated. Increased CO₂ or N₂ gas in the air may be harmful and even fatal. If the ventilation is poor, other methods should be considered in order to ensure safe working environments.

❗ If there is a leakage of petroleum gas or other flammable gas, close the gas supply valve and open doors and windows to ventilate the air. Do not plug or unplug your freezer unit in order to avoid potential explosion or fire.

❗ Only professional technicians or service personnel can install the unit. Failure to do so, may cause electric shock or result in a fire hazard.

❗ The freezer must be securely installed on a firm floor. Installation on an uneven

surface may result in the product tipping over, thereby causing injury and damage.

! Please use the dedicated power supply indicated on the product label to avoid the risk of fire and electric shock.

! If the voltage in use is 10% higher than the rated voltage, a regulator with a capacity of 4000 W or greater must be installed.

! If the power cord needs to be extended, the cross-section of the extended cable must be no less than 14 AWG and no longer than 9 feet for products operating at 220V-240V/50Hz or 220V/60Hz, and no less than 12 AWG and no longer than 3 meters for products operating at 115V/60Hz, in order to avoid the risk of fire or electric shock.

! Your ULT unit is equipped with a standard three-prong power plug (grounded) complying with the standard three-prong socket (grounded) rated 10A. Removal of the ground prong be securely plugged into the socket. A loose plug in the socket may cause fire.

! Never install your ULT in an unprotected area. If the unit is exposed to moisture, there is a high danger of electric shock.

⊘ Do not install your ULT in a damp area or an area subjected to water spray, as this may reduce the degree of insulation and thereby cause electrical leakage or electrical shock.

⊘ Never directly pour water into the unit, as it may cause electrical shock or a short circuit.

⊘ Do not place heavy objects on top of the unit, as a falling object may cause injury.

⊘ Never use gas lines, water mains, telephone lines, or lightning rods as the grounding device for your ULT unit. This type of improper grounding may cause electric shock or other dangers.

⊘ Do not touch any electrical components, switches, or power cords with wet hands. Such actions may lead to electric shock.

! When unplugging the power cord from the socket, please grip the plug itself and pull it out. Do not pull on the power cord as this may strip the wires out of the plug thereby causing electric shock and fire.

! Should there be any Malfunction in the equipment, power off the unit and unplug the power cord from the power supply. Continued operation in an abnormal condition may result in electric shock and fire.

-
- ❗ User must not dismantle, repair or modify the equipment. Such operations may result in fire or personal injury.
 - ❗ Before any repair and maintenance of the freezer, please disconnect the power to avoid electric shock or injury to personnel.
 - ❗ When repairing and maintaining your freezer, take precautions not to inhale any chemicals or aerosols floating inside and outside the unit. They may be harmful to your health.
 - ❗ If the unit is not to be in use for a long period of time, make sure the power cord is unplugged. Deteriorated insulation of the power cord may lead to electric shock or fire.
 - ❗ The freezer must be disposed of by qualified specialized personnel.
 - ⊘ Do not use any unapproved electrical components with the freezer.
 - ⊘ Never store flammable, explosive, or volatile materials inside the unit, and refrain from using any flammable spray near it, as this could potentially lead to an explosion or fire.
 - ⊘ Never store any corrosive chemicals with acid or alkaline properties within the unit, as this may result in damage to its internal components.
 - ⊘ Avoid using glass containers with the unit, as they may shatter at low temperatures, posing a risk of injury.
 - ⊘ Do not climb on top of the unit or place any objects upon it, as falling equipment can lead to potential injury or property damage.
 - ⊘ Do not use any hard objects such as nails or wires in openings or gaps like air ventilation ports. Strictly prohibit accidental contact between hard objects and moving parts to prevent potential electric shock or injury.
 - ❗ After restarting your unit following a power outage or shutdown, ensure that all settings are accurately configured. Unauthorized or accidental alterations in settings may compromise the integrity of stored products.
 - ❗ In the event of a power outage and subsequent restoration, kindly wait for a minimum of 5 minutes before restarting the unit to prevent potential damage to compressors and the refrigeration system.
 - ❗ It is crucial to regularly clean the air filter for the condenser, as a dirty filter can result

in malfunctions or an increase in freezer temperature.

- ❗ During any repair operations, it is essential to wear gloves to safeguard against potential injuries caused by sharp edges or corners.
- ⊘ Strictly refrain from using bare hands to handle any stored products directly, as the frigid temperature of the products and interior walls poses a significant risk of frostbite.
- ❗ When moving the unit, ensure it is not tilted more than 45 degrees.
- ❗ When relocating the unit, please exercise caution to prevent injury to personnel and potential damage to the unit.
- ⊘ It is prohibited to put your hands on the bottom of the storage box door or the compartment door to lift or move the equipment, as this may cause damage to the equipment or lead to injury of personnel.
- ⊘ Do not attempt to use the handle to lift or move the unit to avoid damaging the freezer or injuring personnel.
- ❗ We strongly advise having the unit installed and maintained by a certified professional to mitigate any potential electrical hazards. Furthermore, the replacement of any spare parts, including batteries, should be performed by technicians authorized by the manufacturer.
- ❗ Ensure that all ventilation openings in the enclosure or the built-in structure remain unobstructed.
- ⊘ Do not employ mechanical devices or alternative methods to expedite the defrosting process, except for those specifically recommended by the manufacturer.
- ⊘ Do not damage the refrigerant circuit.
- ⊘ For equipment which use flammable insulation blowing gases, the instructions shall include information regarding disposal of the equipment.
- ❗ The instructions for split-systems that use a flammable refrigerant shall include the substance of the following warning:
 - ❗ In order to reduce flammability hazards the installation of this equipment shall only be carried out by a suitably qualified person.

Usage Precautions

- During normal operation, the unit frame near the front door may feel slightly warm. This is normal, as hot tubing is embedded there to prevent condensation on the frame.
- Before loading samples, ensure the unit temperature has reached the set point. Load samples in batches, not exceeding 1/3 of the unit's capacity per batch, to prevent temperature rise during loading.
- The temperature display reflects the sensor's location inside the chamber. It may differ from the center temperature but will converge over time.
- The left side wall of the equipment is equipped with one access port which can be used as the pass-through for thermocouple wires during testing and validation. Once all test wires are through the access port, ensure that the gap in the port is properly sealed with insulation materials. Failure to seal the access port may affect the operation of the equipment, and the port ring on the outer wall may also accumulate frost and ice.
- Use mild or neutral detergent to clean the unit. Avoid hard wire brushes, acids, gasoline, powder detergents, polishing powders, or hot water, as they can damage paint and plastic components. Do not use gasoline or volatile chemicals on plastic or rubber parts.
- After prolonged use, frost may accumulate on the interior liner and doors. When the frost layer becomes too thick, it can impact refrigeration performance and increase energy consumption. If the thickness reaches approximately 5 mm (1/5 inch), use the provided scraper to remove the frost.
- Before defrosting, temporarily relocate stored samples to another freezer to prevent temperature rise from damaging them.
- The interior walls house numerous refrigeration lines. Avoid using knives, ice picks, or screwdrivers to clear ice and frost as they may damage the liner and refrigeration tubes.
- If the freezer is not in use for an extended period, turn off the power and backup battery, and unplug the power cord.
- EMC Test Claims: The freezer's refrigeration system operates normally, ensuring temperature cooling functionality within the box.
- Electromagnetic Compatibility Requirements:
 - a) This machine meets the emission and immunity standards specified in EN 61326-1.
 - b) Designed and tested as Class A equipment in accordance with CISPR, this machine may cause radio interference in domestic environments, requiring protective measures.
 - c) It is recommended to assess the electromagnetic environment prior to use.
 - d) Using this machine near strong radiation sources (e.g., unprotected video sources) is prohibited, as it may interfere with normal operation.

Product Installation

■ Installation environment

- Ambient temperature: 10°C to 32°C. The optimal temperature range is 18°C to 25°C. If required, utilize an air-conditioning system to maintain the desired ambient conditions.
- Environmental humidity: less than 80% RH.
- Avoid excessive dust accumulation.
- Avoid mechanical shaking or vibration.
- Atmospheric pressure 80kPa-106kPa.
- Mains/power supply: **Rated voltage \pm 10%**.
- Mains/power frequency: 50Hz-60Hz.
- Current consumption: 100V-230V(50Hz) 15A-6A;
100V-220V(60Hz) 12A-6A.
- Transient state: Category II (over voltage category).
- Pollution Degree: 2.

Caution

- A ULT is highly sensitive to its operational environment, and if it is not installed in accordance with the aforementioned conditions, its reliability may be compromised.
- This unit is exclusively designed for indoor use.

■ Installation site

- Avoid installing the unit in a confined space. Ensure the doorway is wide enough to allow for easy and seamless movement of the unit into and out of the room, if necessary. This facilitates prompt and straightforward repairs, preventing potential property damage.
- Choose a flat and stable surface for installation.
- Ensure good ventilation and avoid direct sunlight exposure.
- Do not share the power socket with other devices. Ensure the power plug is securely inserted into the socket.
- The freezer's power cord should not be twisted or pinched.
- The freezer must be properly grounded.
- If the socket is not equipped with a grounding wire, it must be installed by a professional engineering technician before use.

Warning

- Do not ground the freezer through gas lines, water mains, telephone lines, or lightning

rods, as this strictly prohibits the risk of electric shock.

- After installation, ensure the power plug is readily accessible for unplugging in case of emergency. Additionally, no object should obstruct the ventilation port of the freezer.

■ Preparation before use

1. Remove all packaging materials and straps.

2. Verify Supplied Accessories

Check the items in the package against the enclosed packing list. Should any discrepancy arise, please contact the manufacturer.

3. Placement Conditions

Maintain a minimum clearance of 30cm around the freezer for adequate ventilation.

4. Adjust Leveling Legs

Rotate the leveling legs clockwise to extend them and level the unit with the floor, ensuring stability during use.

5. Standing

After adjusting and cleaning the unit, do not immediately connect the power cord. The freezer needs to be placed in its intended location for at least 24 hours before connecting the power to ensure stable operation.

6. Indoor use; not use in wet condition.

To handle the freezer before unpacking, a forklift or package carrier may be used. If using a forklift, insert the tines at the bottom of the blocking panel from the front or back of the freezer to move it. If using a package carrier, lift it from the bottom of the blocking panel and only lift from one side of the freezer.

After unpacking, to move the freezer, you may push it using the wheels.

During handling, ensure the inclination angle of the freezer does not exceed 45°.

Please be careful not to slip while pushing the freezer.

■ Power on the first time

When starting the unit for the initial time, please adhere to the following procedures:

Figure 1

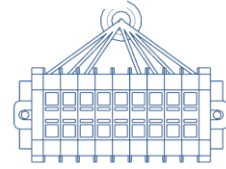
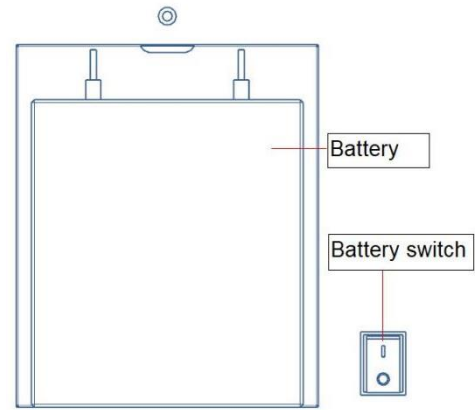
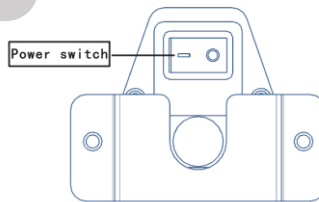

Figure 2



1. While keeping the unit empty, please plug in the power cord to a dedicated power socket that meets all electrical requirements.



2. To connect the freezer to the power supply, first plug it into a dedicated power socket. Then, locate the power switch on the rear of the freezer (as illustrated in Figure 1) and turn it on. After that, open the freezer door, find the battery switch next to the battery (as illustrated in Figure 2), and activate it.

3. If the unit is equipped with an optional backup cooling system, please ensure that the backup system is turned off.

4. Set the unit to the desired temperature. After freezer reaching set temperature, monitor its performance for 24 hours to ensure it is functioning properly and undergoing normal cycling.

5. Once the unit is confirmed to be operating properly, it is ready to be loaded with samples. Load the samples into the unit in batches, ensuring each batch comprises less than one-third of the unit's total capacity. Ensure that the unit is capable of maintaining the set temperature for at least 8 hours without cycling excessively.

6. If the unit is equipped with an optional backup cooling system, activate it.

- Your ULT unit should be maintained and monitored by trained personnel. It is recommended to inspect and record the unit's working status every 2 to 4 hours on a daily basis. If a malfunction occurs and the freezer temperature rises, promptly address the issue. If the problem cannot be resolved promptly, remove the stored samples and transfer them to another unit that meets the required temperature to prevent potential damage to the samples.
- Before storing samples in the freezer, ensure that the freezer's temperature has reached the desired set point to prevent any potential damage or loss.
- All ultra-low temperature storage units are designed for low-temperature storage. It is advisable not to load excessive amounts of samples into the unit simultaneously, as overloading may compromise its performance and lead to overheating of the freezer and compressors. Samples should be loaded in batches, gradually decreasing the temperature setting with each batch. This process should be repeated until the final desired temperature is achieved.
- Do not utilize unauthorized mechanical tools or any other unauthorized methods to expedite the defrosting process.
- Do not damage the refrigeration circuit.
- Do not use any unapproved electrical components in the freezer.

■ Operation after a power outage

Warning

- Your ULT freezer's control settings are stored in its memory system, enabling it to resume operation with the previous settings after a power outage and recovery.
- Before turning the power unit back on after an outage and to avoid damaging the compressors, ensure that the refrigeration system has been off for at least 5 minutes.
- If the unit is not in use for a long period of time, ensure that the power cord is unplugged to prevent potential electric shock or fire due to deteriorated insulation of the power cord.

Product Description

■ Freezer Components

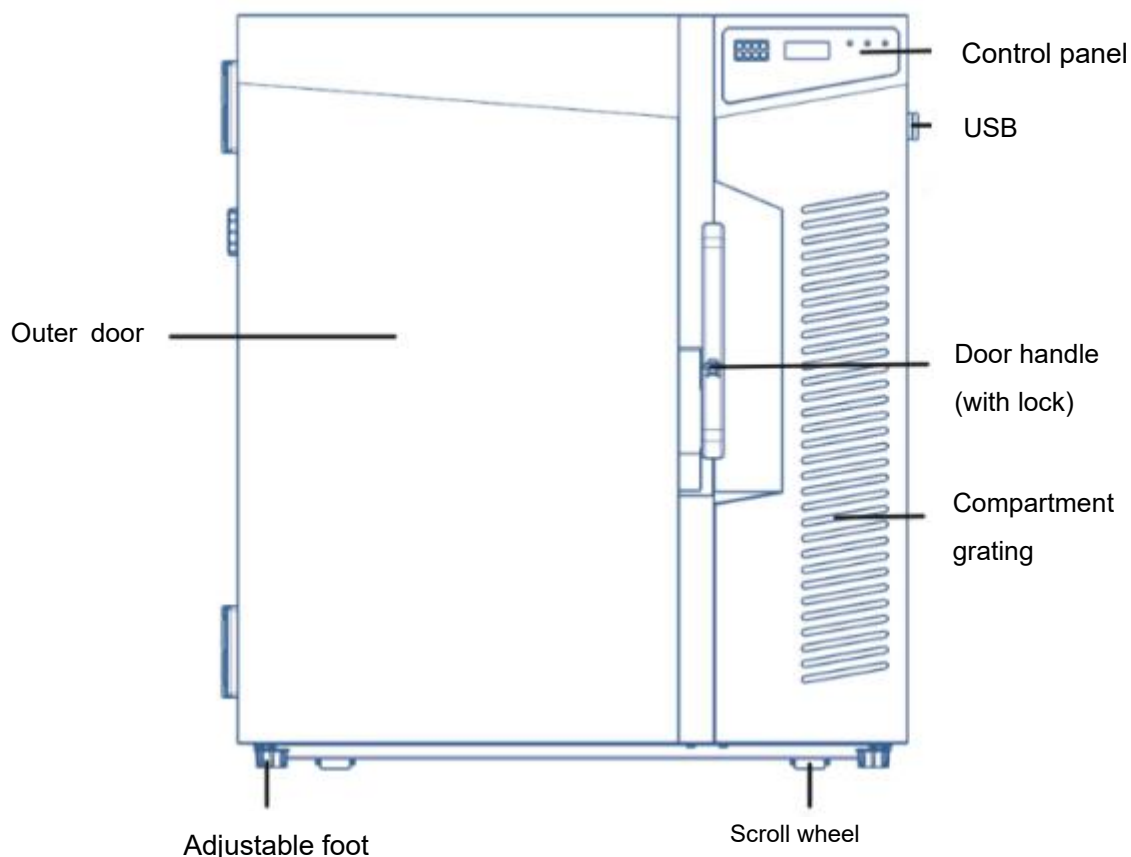

■ Control panel

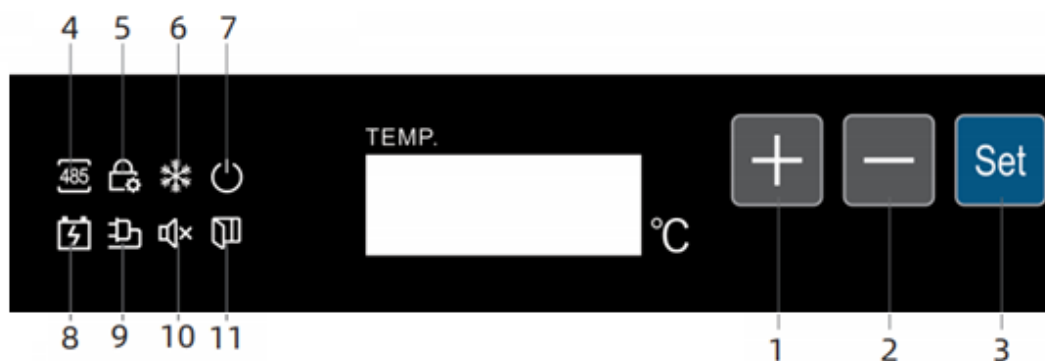

Description of buttons and icons

1 - Increment ; 2 - Decrement; 3 - Set/mute button

4 - 485 communication; 5 - Key lock; 6 - Compressor start; 7 - Power

8 - Low battery; 9 - Power failure; 10 - Alarm mute; 11 - Door opening indication

Usage

■ Check the ambient temperature

When the key is locked, press "Set", and the digital tube displays the ambient temperature. After 5 seconds of no operation or pressing "+" or "-", it returns to normal display. When the button is not locked, press "Set", and the digital tube displays the ambient temperature. After 5 seconds of no operation, it returns to normal display.

■ Mute the alarm sound

When the alarm sounds, press "Set" to cancel the alarm and enter the view of ambient temperature status;
When the alarm tone is canceled, press "Set" to restore the alarm tone and enter the view ambient temperature status;
When the button is not locked and the ambient temperature status is being viewed, pressing "Set" can cancel or resume the alarm sound.

■ Key lock

When the keys are not locked, no key operation for 60 seconds or pressing "+" and "-" simultaneously for 3 seconds (the buzzer sounds twice when the key operation is locked) will lock the keys. When the keys are locked, you can view the ambient temperature and mute, but other key functions are locked and the buzzer sounds twice during operation.

■ Key unlock

In the key locked state, press "+" and "-" simultaneously for 3 seconds. The digital display will show "0000". Adjust the password to "5" using "+" and "-". After the password is correct, it will return to normal display, and the buzzer will sound once.

■ Parameter setting

When the button is not locked, long press the set button for 3 seconds, the digital tube displays "PS1", press "+" and "-" buttons to switch between menus and corresponding parameters, press "Set" and "+" and "-" buttons to select menus or adjust parameters, long press "Set" for 3 seconds to save the parameters and exit the parameter setting.

Menu	Description	Settings Range	Default Settings	Unit
Set	Temperature Settings	-86.0~-40.0	-80.0	°C
H	High Temperature Alarm Setting	0.0~10.0; 0: Cancel Alarm	10.0	°C
L	Low Temperature Alarm Setting	0.0~10.0; 0: Cancel Alarm	10.0	°C
n	Check current time - Year	--	--	/
y	Check current time - Month	--	--	/
r	Check current time - Day	--	--	/
S	Check current time - Hour	--	--	/
F	Check current time - Minute	--	--	/
PT	Print Interval	0~240	30	min
tH1	Ambient Temperature High Alarm Setting	20.0~80.0	35.0	°C
PS1	User Menu Password	0~9999	5	/
b1	Hardware Version	--	2.0	/
b2	Software Version	--	2.2	/

■ USB data export

When the USB disk is connected to the USB interface, the buzzer of the recorder will sound once, and the upper digital tube will display "USB" and the lower digital tube will display "ON"; When the data code "on" is transmitted, a PDF file of the data for the current month and the previous month is generated on the USB disk. After the data transmission is completed, the buzzer beeps once and the digital tube displays "End". After 6 seconds, the digital tube returns to normal display.

Note: When there is less data, the digital tube does not display the "USB""on" and "end" prompts.

Display and Operational Anomaly Warnings

Code	Status
H1	High inner temperature alarm
L1	Low inner temperature alarm
H2	High ambient temperature alarm

H3	Hot condenser alarm
E1	Main sensor fault
E3	Ambient temperature sensor fault
E4	Condenser sensor fault
bL	Low battery alarm
PF	Power alarm
do	Door opening alarm
Er	When the recorder is not masked and the recorder is not connected.
Pr	When the recorder is not masked and an error occurs in file generation on the USB drive.

 **Caution**

- 1.The light alarm cannot be canceled until the fault is resolved; however, when the alarm sound is active, it can be canceled by pressing the "Set" button, which also displays the ambient temperature.
- 2.When the alarm sound is canceled, it can be restored by pressing the "Set" button, which also displays the ambient temperature.
- 3.When the keys are not locked and you are viewing the ambient temperature, pressing "Set" can cancel or restore the alarm sound.
- 4.During normal operation of the freezer, it is necessary to turn on the battery switch to charge the battery.
5. In the event of a sudden power outage, the battery will supply power to the display screen to ensure normal operation. When the battery power is insufficient, the battery will stop providing power and the display screen will no longer function.
6. If you want to completely cut off power when the battery is capable of normal power supply, simply unplug the AC power cord and then turn off the battery switch on the freezer. At this point, the display screen will not show anything.

■ Remote alarm terminal

The remote alarm terminal is installed on the rear side of the freezer's engine cabin, and the alarm signal will be output by this terminal. The load capacity of the terminal is DC 30V, 2A.

The remote alarm terminal is divided into: Normally open, normally closed, common terminal. Users may select normal open or normal close according to their own requirements.

Standard RS485 port can be used to transmit freezer temperature data to customer's software for monitoring.

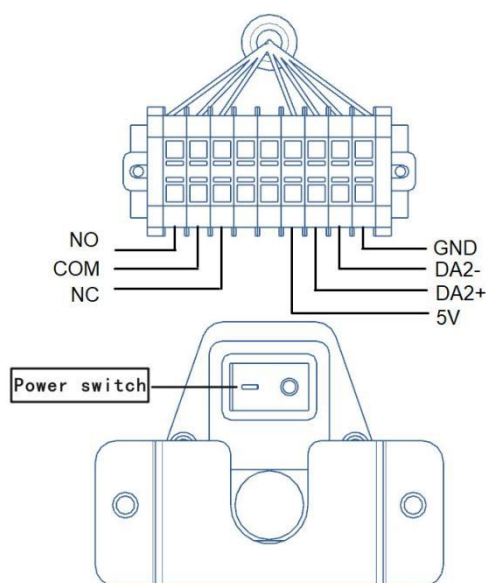

Cleaning and Maintenance

■ Cleaning of components

- Before undertaking any repairs to the freezer, make sure to switch off the power supply to prevent electrical shock or injury to personnel.
- Make sure to not inhale any medication or suspended particles around the freezer during maintenance, as this may be harmful to your health.

■ Cleaning the freezer

- The freezer needs to be cleaned in a timely manner.
- Use a dry cloth to wipe off a small amount of dust on the outside of the freezer, inner chamber and all accessories. If the storage box is very dirty, use a clean cloth soaked in neutral detergent to remove dirt and wipe off the remaining detergent with a wet cloth, then use a dry cloth to wipe.
- Do not pour water on the outside of the freezer or in the freezer, otherwise it may damage the electrical insulation and cause failure.
- Compressors and other mechanical parts are completely sealed and do not require lubrication.
- Remove frost or ice from the inner wall and clean the condenser filter once a month.

■ Clean the condenser filter

It is recommended to clean the filter once a month. If the filter is blocked, it will affect the cooling effect of the storage box and reduce the service life of the product. Please follow the following steps to clean the filter:

1. Open the higher cover;
2. Remove the grid installed behind the cover;
3. Pull the filter out of the cabinet grid upwards;
4. Wash the filter with water and dry it;
5. Put the filter back into the grid.

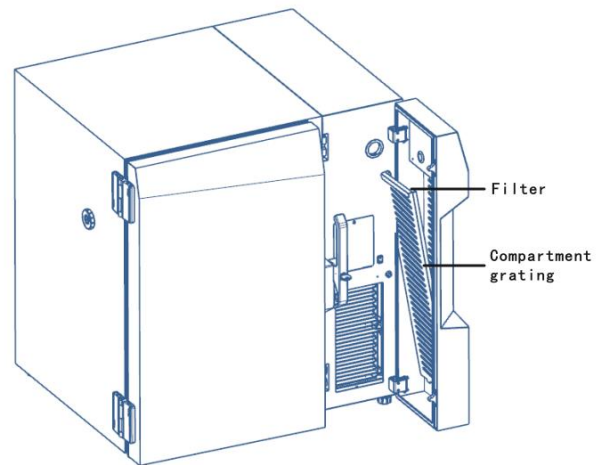

■ Defrosting on the inner wall

Frost may cause cracks between the box and the door seal, resulting in poor insulation. Use the defrosting shovel included with the storage box to defrost the inner door.

The following steps are for natural defrosting:

If there is an auxiliary cooling device, turn it off.

Remove the items from the box and transfer them to an environment suitable for their storage.

Turn off the power switch.

Open the outer and inner doors of the freezer to allow the outer door to open naturally for a period of time to defrost.

Wipe the water accumulation at the bottom of the box with a dry cloth.

After cleaning the box and inner door, restart the freezer.

Replace the items in the fully cooled box.

If there is an auxiliary cooling device, restart it.

Please note that do not use sharp tools such as knives or screwdriver to defrost.

■ Battery maintenance

- When the storage box is continuously powered on, please check the battery level every fifteen days. When the battery level is low, please make sure the battery switch is in the "ON" position, and the battery will be charged. After the battery is charged for one week, please retest the battery level. Normally, the battery level should be sufficient at this time. If the battery level is still low, it is recommended to replace the rechargeable battery.
- Batteries are consumables, and the battery life is about 2 to 3 years. If the battery is used

for more than 3 years, there may be a situation where the power is cut off without an alarm. It is recommended that users contact our after-sales service personnel in advance.

■ **Scrapping of the freezer**

- If the freezer is left unused in an unsupervised area for a long time, make sure children do not approach the freezer and the door is not completely closed.
- Disposal of the freezer shall be carried out by relevant personnel. To prevent incidents such as suffocation, the door must be removed.

Recycle of Rechargeable Battery

The freezer is equipped with a rechargeable battery, which is recyclable. When the battery reaches the end of its service life, please contact the local relevant battery recycling agency for inspection or dispose of the battery properly.

■ Location of the battery

The built-in battery is used for power failure alarm, and the battery is located in the battery compartment. After opening the cabinet door, you can see the cover of the battery compartment. To prevent electric shock, the disassembly work should be carried out by professional engineers.

■ Removal of the battery

1. Turn off the power switch and unplug the power plug from the socket.
2. First open the left door of the strongbox, and then open the right cabin door.
3. Unscrew the screw of the battery compartment cover to remove the battery compartment cover;
4. Remove the battery and unplug the battery connector;
5. Recycle or dispose of the battery correctly according to regulations.

Note: When replacing the battery, make sure the brown wire is connected to the positive pole of the battery and the black wire is connected to the negative pole of the battery. Do not reverse it. Otherwise, it is easy to burn out the charging circuit of the computer board, resulting in the computer board unable to charge the battery.

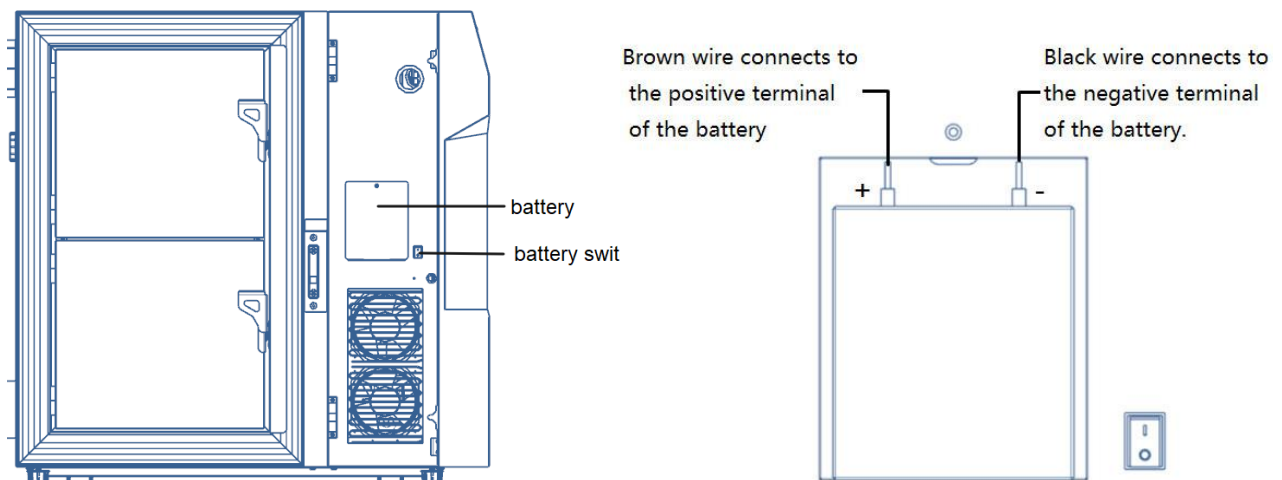

Trouble Shooting

Please take below chart as reference for some common malfunction.

Fault	Troubleshooting solution
Start failure of the box	Is the power connection normal? Is the power switch in the "ON" position?
	Is the power voltage too low?
	Check if there is input voltage from outside?
Poor cooling	Is the ambient temperature too high?
	Is the inner door closed tightly? Is the outer door closed tightly? (Frost on the box and door seal may damage the sealing of the door.)
	Is the condenser filter dirty or clogged?
	Is the temperature set correctly?
	Is the box away from the direct sunlight?
	Is the box close to the heat source?
	Are the knobs of the test through holes correctly placed?
Noise	Is the storage box installed on a solid and flat ground?
	Does the outer shell of the storage box come into contact with other items?
	Is the storage box leveled with leveling feet?

Freezer principle and circuit diagram

■ Freezer schematic diagram

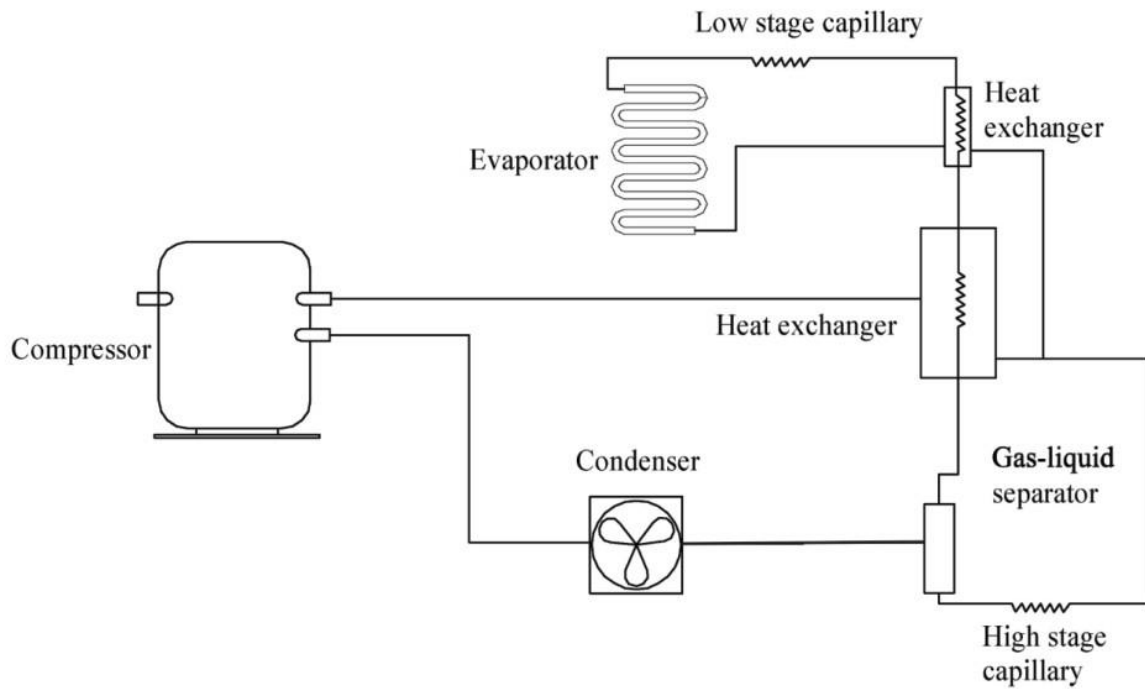

■ Circuit diagram

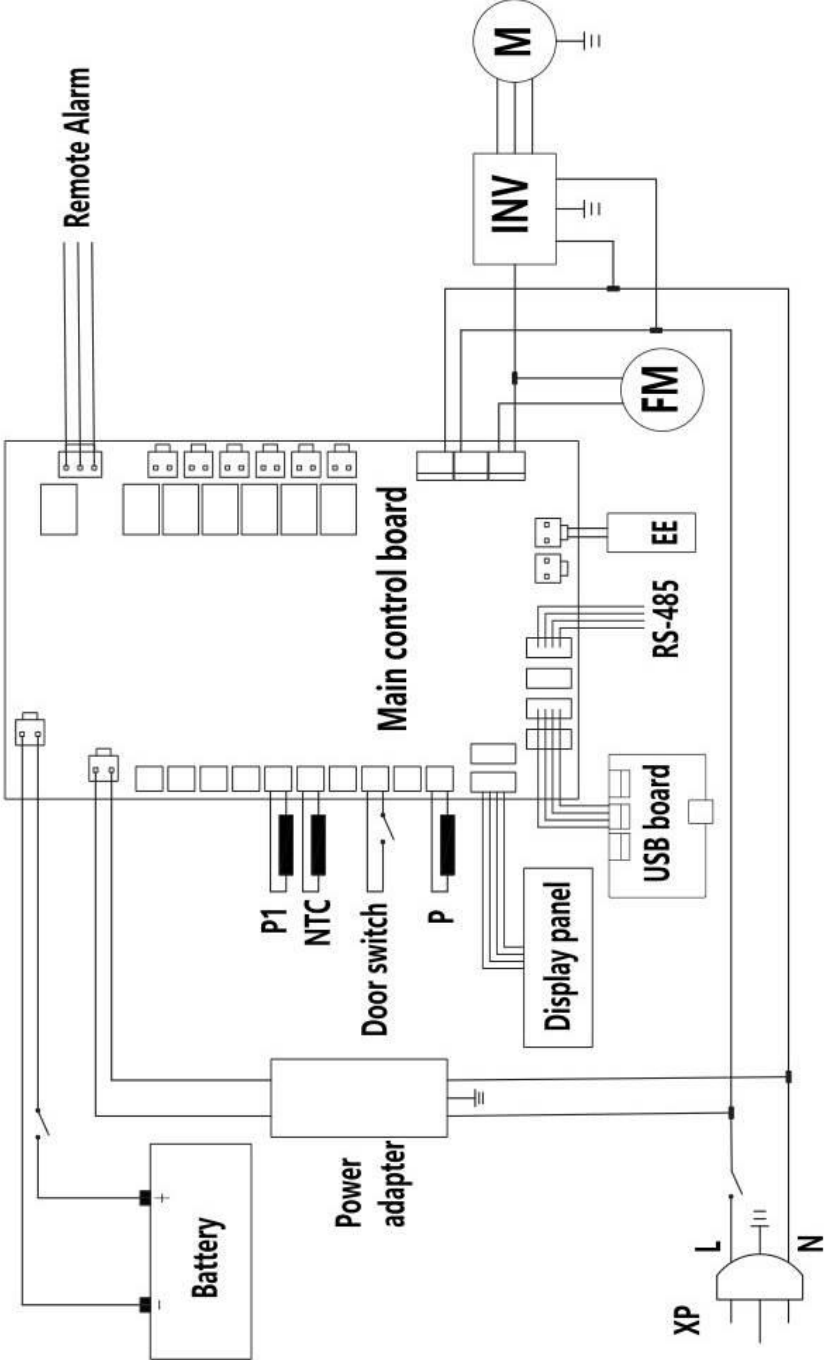

XP-Power plug P-PT1000 Temperature sensor P1-Ambient temperature sensor
 EE-Electric heating element M-Compressor FM-Condenser fan INV-Frequency Converter

Specification and technical data

Model	K203ULT
Ambient temperature	10~32℃
Electric protection type	I
Power supply (V/Hz)	110V,50/60Hz
Temperature range(.C)	-40~-86
Rated current(A)	110V/5.0A
Input power(W)	500
Power consumption(KW.h/24H)	4.8
External dimension W*D*H (mm)	760*680*818
Effective volume(L)	100
Net weight(kg)	102
Refrigeration method	Direct cooling
Refrigerant	Mixed Gas
Battery	Rechargeable battery, DC12V, automatic charging
USB	Optional

Note: The company lays emphasis on technological innovation, and the product parameters are subject to changes without prior notice.

■ Packing list

Item	K203ULT
User manual	1
Ice scraper	1
Key	2
Shelf	1

Certificate of Quality

Checker: 