

LHP-20-RX

Images



Product Description

Hazardous location refrigerators meet NFPA and OSHA guidelines for Hazardous Location, Class 1, Division II, Groups A,B,C & D guidelines. These units utilize non-sparking and/or ATEX rated components and are engineered for use in environments where volatile/explosive conditions could potentially exist.

Models feature a microprocessor temperature controller, allowing for precise temperature control, recovery and maintenance versus mechanical style thermostats. Our Ultra Series refrigerators run on natural, hydrocarbon refrigerant for environmental health and energy efficiency. For storage of flammable or volatile materials within typical laboratory or non-volatile environments, see Flammable Material Storage units.

Certifications



General Description and Application

Storage capacity (cu. ft)	20
Door	Right Hinged
Shelves	5 Adjustable (4 full plus half shelf)
Freezer Compartments	Non-applicable
Baskets	Non-applicable
Mounting	Leveling Legs
Interior lighting	Non-applicable
Airflow management	Forced draft air circulation
External probe access	Non-applicable
Insulation	Cabinet is foamed-in-place with EPA compliant high density urethane foam
Exterior materials	White powder coated steel
Access Control	Keyed door lock
General warranty	Two (2) year parts and labor warranty
Warranty Disclaimer	Products require 4" of clearance around back and sides of the unit for proper ventilation - improper installation will void the warranty and will lead to temperature maintenance issues, overheating and possible failure
Product Weight (lbs)	235
Shipping Weight (lbs)	260
Rated Amperage	2.5 Amps
Power Plug/Power Cord	Power cord is not included - final power connections at site must be hardwired to meet local codes
Facility Electrical Requirement	115V, 60 Hz
Agency Listing and Certification	ETL, C-ETL listed and certified to UL471 standard, hydrocarbon refrigerant safety, Energy Star Certified. Units meet NFPA and OSHA guidelines for Hazardous Location, Class 1, Division II, Groups A,B,C & D guidelines.

Refrigeration System

Refrigerant	R600a
Defrost	Cycle

Controller, Configuration, Alarms and Monitoring

Controller technology	Microprocessor temperature controller with digital temperature display, °C/°F switchable
Display technology	Standard Digital Temperature Display
Adjustable Temperature Range	1°C to 10°C
External alarm connection	State switching remote alarm contacts
Alarms	Audible and visual high and low temperature alarms
Controller probe	Non-applicable
Digital Communication	Non-applicable
Data Transfer	Non-applicable
Disclaimers	Power cord is not included - final power connections at site must be hardwired to meet local codes Indoor use only, +18°C to +26°C (+65°F to +78°F), <70% RH Specifications are subject to change

Dimensions

	Width (in.)	Depth (in.)	Height (in.)	Door Swing (in.)	Total open Depth (in.)
Exterior	30.75"	29"	74.625"	29"	58"
Interior	24.75"	20.75"	65.25"		

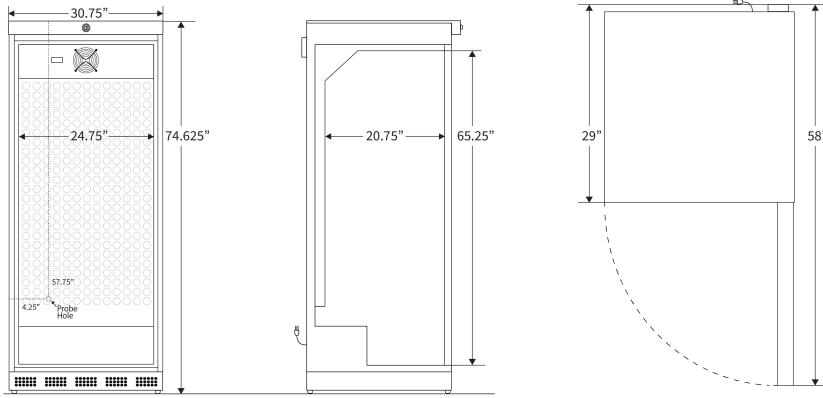

Contact

Customer Service

800-521-0754

sales@labrepco.com