

LHCT-30-FM3

Product Description

This Ultra Touch manual defrost touchscreen freezer redefines precision and user experience for critical sample storage. These models offer exceptional temperature uniformity and extensive data logging and charting capabilities for auditing and compliance. Access a 24-hour temperature chart and data logging capabilities through an intuitive touchscreen interface. Experience an extensive array of customizable audible and visual alarms supported by battery backup and remote alarm contacts. These units utilize microprocessor temperature technology, protecting samples down to -33°C. They also feature natural hydrocarbon refrigerants for EPA SNAP compliance and eco-friendly cooling. This freezer provides an energy-efficient and high-performance solution for any laboratory needing precise temperature control and data logging capabilities.

Images



Certifications



General Description and Application

Storage capacity (cu. ft)	30 Cu. Ft.
Door	One (1) solid swing, right hinged; stainless steel door handle; magnetic door gasket
Interior	Five (5) inner fast-freeze compartments with doors for temperature maintenance
Shelves	Four (4) fixed evaporator shelves
Mounting and Installation	Caster platform
External probe access	3/4" probe access port on rear wall
Insulation	EPA compliant high density urethane foam
Exterior materials	Powder coated steel
Access control	Keyed door lock
General warranty	Two (2) year parts and labor warranty
Compressor warranty	Five (5) year compressor parts warranty
Product Weight (lbs)	330
Shipping Weight (lbs)	360
Rated Amperage	3.3 Amps
Power Plug/Power Cord	NEMA 5-15P plug, 6 ft long cord
Facility Electrical Requirement	110 - 120V AC, 15A breaker, NEMA 5-15 receptacle
Agency Listing and Certification	UL listed per UL 60335-1 and UL 60335-2-89 standards; c UL listed per CSA C22.2 No. 120 standard

Performance

Uniformity (Cabinet air)	+/- 2.5°C
Stability (Cabinet air)	+/- 3.5°C
Maximum temperature variation (Cabinet air)	7.5°C Total
Energy Consumption (kWh/day)	7.7 kWh/day
Average Heat Rejection (BTU/hr)	1100 BTU/hr
Pull down time to nominal operating temp	120 min (empty)

Refrigeration System	
Compressor	Hermetic, variable speed
Refrigerant	EPA SNAP compliant R290 propane
Condenser	Static - exterior walls of cabinet with auxiliary fan
Evaporator	Evaporator shelves
Defrost	Manual defrost

Controller, Configuration, Alarms and Monitoring	
Controller technology	Microprocessor temperature controller with variable frequency compressor control
Battery Backup	Temperature display and alarm only (no active cooling)
Display technology	Touch screen digital temperature display with user friendly interface, real-time operational display clock, active temperature scale bar display, resettable 1-point min/max history, digital 24-hour temperature chart, and temperature data logging
Adjustable Temperature Range	-27° C to -33° C
External alarm connection	Remote alarm contacts
Alarms	Adjustable alarm volume, Audible and visual high and low temperature alarms, sensor error alarm, power failure alarm, door ajar alarm, low battery alarm, alarm validation (audible, visual, and remote alarm), alarm mute with ring back, and customizable alarm time delay settings
Display Probe	Product simulator bottle with glass bead media

Disclaimers

Defrosting of the unit will need to be performed periodically to prevent severe ice build-up.
 Indoor use only, +18° C to +26° C (+65° F to +78° F), <70% RH
 Specifications are subject to change.
 Equipment requires 4" of clearance around back and sides of the unit for proper ventilation – improper installation will void the warranty and will lead to temperature maintenance issues, overheating and possible failure.
 Performance claims are based on testing at 22°C ambient using unbuffered air temperatures in an empty freezer at steady state operation.
 Performance may vary with environmental conditions, product load, or door openings.

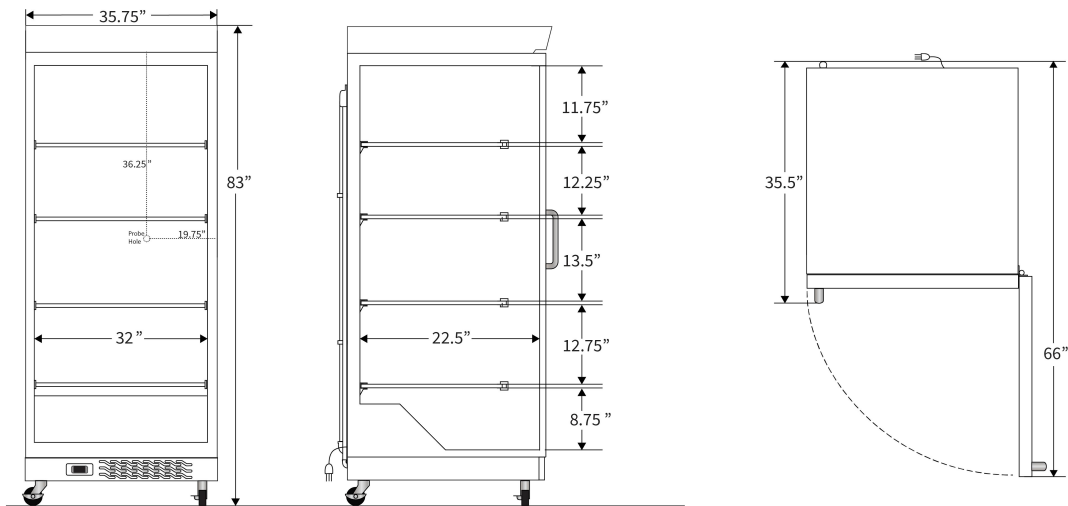

Contact		
Customer Service	800-521-0754	sales@labrepc.com