

MCO-233AICUVHX-PA

cellIQ™

Active Humidification CO₂ Incubator with
H₂O₂ Decontamination

8.1 cu.ft. | 230 L



MCO-233AICUVHX-PA



Precision incubation depends on stable CO₂, temperature, and humidity control. Routine door openings can disrupt humidity and introduce variability in cell culture conditions. This incubator integrates passive and active humidification systems to maintain tightly regulated humidity and minimize edge-effect variability. It supports high-throughput screening, low-volume samples, and organoid culture. With SafeCell UV-LED technology and an H₂O₂ decontamination system, it delivers faster humidity recovery while maintaining active decontamination performance compared to previous models.

Creating a Hybrid Humidification System

The active humidification system uses an external reservoir of distilled water that is pumped through a steam generator to increase the incubator's humidity to within ±1% RH accuracy between 80–90%. A separate water pan provides the primary humidity source for maintaining levels above 90% during extended cell-culture experiments.

Rapid Humidity Recovery to Combat the Edge Effect

Compared to earlier models using only passive humidification, the hybrid system cuts humidity recovery time by about 50% after 30- and 60-second door openings. This faster recovery helps maintain stable conditions and reduces sample volume loss across wells and plates in the CO₂ incubator.

Integrated Decontamination & Maintenance Guidance

Step-by-step visual and written instructions for multiple decontamination methods are available directly on the incubator's display. When an alert occurs, an on-screen QR code provides quick access to detailed information and recommended actions, simplifying troubleshooting and maintenance.



Redesigned Display and Graphics

The new 7-inch color LCD touch panel has an updated interface with clear icons and refined graphics for intuitive operation. It consolidates notifications, troubleshooting tools, data logging, and access to the instruction manual via QR code in a single display.

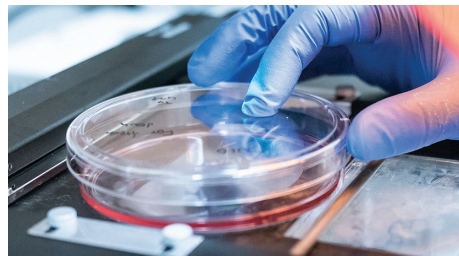

Dual IR Sensor

The dual IR sensor provides stable, drift-free CO₂ measurements even under fluctuating humidity conditions. It remains inside the chamber during H₂O₂ decontamination cycles, ensuring accurate monitoring without the need for removal or recalibration.



Time-Saving Decontamination

The H₂O₂ decontamination system disinfects the chamber in under three hours, achieving at least a six-log reduction of major contaminants. This delivers a faster turnaround than high-heat decontamination cycles, which can take 11 hours or more.



Model MCO-233AICUVHX-PA shown with humidity tank closed and then open.

Rapid Humidity Recovery Using a Hybrid Humidification System

The hybrid humidification system rapidly restores humidity levels after door openings by combining an active steam generator with an internal humidity sensor that adjusts levels back to the setpoint. Humidity above 90% is sustained through the coordinated use of active steam and a passive water pan. A dew-stick provides dehumidification without the need for pumps, filters, or access ports, ensuring stable and recordable humidity control throughout experiments.

Comparison of Humidity Recovery Speed After Door Opening (30 and 60 seconds)

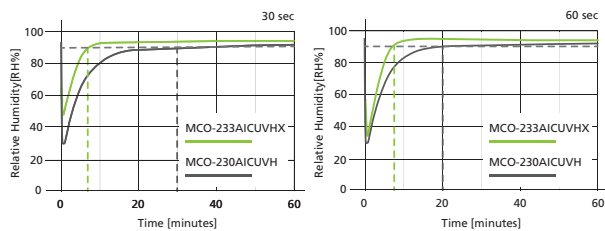

Dimensions

Unit : inch | mm

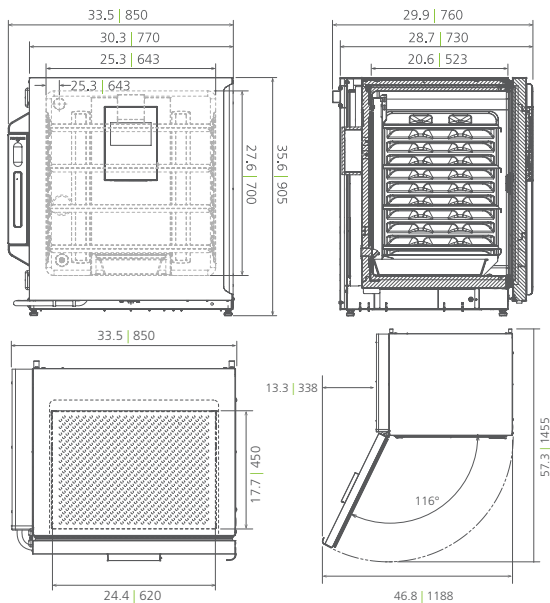

PHC Corporation of North America
1300 Michael Drive, Suite A, Wood Dale, IL 60191
Toll Free USA (800) 858-8442, Fax (630) 238-0074
www.phchd.com/us/biomedical

Printed in USA | 06 | 05 | 2026 | MCO-233AICUVHX-PA_Prd_Sheet | Rev 2 | vf

Model Number		MCO-233AICUVHX-PA
External Dimensions (W x D x H) ¹⁾	inches mm	33.5 x 28.7 x 35.6 850 x 730 x 905
Internal Dimensions (W x D x H)	inches mm	25.3 x 20.6 x 27.6 643 x 523 x 700
Volume	cu.ft. liters	8.1 230
Net Weight	lbs kg	198 90
Performance		
Warranty ²⁾		3 years parts and labor, 5 years CO ₂ sensor
Temperature Control Range and Fluctuation ³⁾	°C	+5 above ambient to +50, ± 0.1
Temperature Uniformity ³⁾	°C	± 0.25
CO ₂ Control Range and Fluctuation ³⁾	%	0 to 20, ± 0.15
Humidity Control & Fluctuation	% RH	80-90% ± 1% RH or lower, 91-95% ± 5% RH
Control		
Controller		Microprocessor
Temperature Sensor		Thermistor
Display		Color LCD touchscreen readable in 0.1 increments
Gas Sensor	CO ₂	Dual beam IR
Humidity System		Hybrid on-demand steam generation with humidifying pan*
Construction		
Exterior Material		Painted steel (rear cover coated steel)
Interior Material		Stainless steel copper enriched alloy
Outer Door	qty	1
Field Reversible Door		Included
Inner Door	qty	1 (sealing tempered glass with positive latch)
Humidity Tank Humidity Pan	qty	1 (stainless steel) 1 (stainless steel)
Total Water Capacity		2L water tank 1.5L humidifying pan
Shelves	qty	4 (stainless steel copper enriched alloy)
Shelf Dimension (W x D x H)	inches mm	24.4 x 17.7 x 0.5 620 x 450 x 12
Max. Load per Shelf	lbs kg	15 7
Max. Total Load	lbs kg	61.6 28
Max. Shelf Capacity	qty	10
Access Port / Position	qty	1; rear upper left
Access Port Diameter	inches mm	1.2 30 (with silicone (non-VOC) stopper)
Leveling Feet	qty	4
Decontamination Control		
InCu-saFe Chamber, Plenum, Shelves	passive	Included (stainless steel copper enriched alloy)
SafeCell UV Light System	passive/active	LED-based; MCO-LUVS-PA (included)
Hydrogen Peroxide (H ₂ O ₂) Vapor	active	Included
Alarms (V=Visual Alarm, A=Audible Alarm, R=Remote Alarm)		
Power Failure		V-A-R
Temperature Deviation	high/low	V-A-R
Gas Deviation	CO ₂ high low	V-A-R
Supply Empty	CO ₂	V-A-R
Door Open		V-A
Electrical and Noise Level		
Power Supply		115V, 1Ø, 60Hz, NEMA 5-15P requires NEMA 5-15R receptacle
Noise Level ⁴⁾	dB(A)	25
Options		
Hydrogen Peroxide (H ₂ O ₂) Vapor Board		Included
Outer Door - Password Access Electronic Lock		Included
H ₂ O ₂ Vapor Generator		MCO-50HP-PW
H ₂ O ₂ Reagent	6 pack	MCO-20H2O2-PV
CO ₂ Gas Pressure Regulator	psi	0 - 15; MCO-100L
Automatic CO ₂ Cylinder Changeover System		MCO-21GC-PW
InCu-saFe Shelf		MCO-230SF-PW
InCu-saFe Shelf-Reinforced	lbs kg	66 30 (MCO-230RT-PW)
Double Stacking Bracket ⁵⁾		MCO-170PS-PW
Stacking Plate		MCO-230SB-PW
Roller Base		MCO-230RB-PW
Communication and Monitoring System		
Wireless, Cloud-Based, Automatic Data Management		LabSVIF™ Gen 3 Compatible
4-20mA Analog Output		Included; Temperature 25-50 °C CO ₂ Density 0-20% 0-100% RH
MODBUS Interface Board		MTR-MODB1-PW

¹⁾ Exterior dimensions of main cabinet and water tank only, excluding handle and other external projections

²⁾ Current warranty offered at time of printing and may be subject to change; US and Canada only

³⁾ Ambient temperature 23°C, setting 37°C, CO₂ 5%, no load

⁴⁾ Nominal value, background noise 20 dB(A)

⁵⁾ If stacking two incubators, make sure the appropriate securing hardware is used

⁶⁾ The purchase of the vapor generator and H₂O₂ reagent is still required for decontamination

* Depending on humidity setting

Note: Additional options available.

Specifications are subject to change without notice.

For latest specification information, contact PHC Corporation of North America at info@us.phchd.com.

Performance data herein is based on independent testing at time of publication.