

### Product Data Sheet

17 Cu. Ft. Ultra Touch Series Flammable Material Storage Refrigerator

#### Images



#### Product Description

Flammable storage refrigerators meet the requirements of NFPA 45 and NFPA 30 for cold storage of flammable and combustible materials in unclassified laboratory locations. Utilizes non-sparking and/or ATEX rated components to ensure an intrinsically safe interior for flammable materials in sealed containers. These units feature temperature alarms, keyed door locks, interior shelving, probe access, and microprocessor temperature control.

Our Ultra Touch Series refrigerators showcase elite features including state-of-the-art touchscreen controllers, advanced alarms and data logging capabilities and unparalleled temperature control. All units run on natural, hydrocarbon refrigerant for environmental health and energy efficiency.

#### Certifications



#### General Description and Application

Storage capacity (cu. ft)	17
Door	Solid, right hinged, magnetic door gasket for positive seal
Shelves	5 Adjustable
Freezer Compartments	Non-applicable
Baskets	Non-applicable
Mounting	Leveling Legs
Interior lighting	Non-applicable
Airflow management	Forced draft circulation
External probe access	Rear wall port (3/4") dia.
Insulation	Cabinet is foamed-in-place with EPA compliant high density urethane foam
Exterior materials	White powder coated steel
Access Control	Keyed Door Lock
General warranty	Three (3) year parts and labor warranty
Compressor Parts Warranty	Five (5) year compressor parts warranty
Warranty Disclaimer	Products require 4" of clearance around back and sides of the unit for proper ventilation - improper installation will void the warranty and will lead to temperature maintenance issues, overheating and possible failure
Product Weight (lbs)	242
Shipping Weight (lbs)	267
Rated Amperage	3 Amps
Power Plug/Power Cord	NEMA 5-15 Plug, conforms to UL471 requirements
Facility Electrical Requirement	115V, 60 Hz
Agency Listing and Certification	ETL Listed, Energy Star Certified

#### Refrigeration System

Refrigerant	R600a
Defrost	Cycle

#### Controller, Configuration, Alarms and Monitoring

Controller technology	Microprocessor temperature controller with digital temperature display, °C/°F switchable
Display technology	Touch screen digital temperature display with user friendly interface, real-time operational display clock, active temperature scale bar display, resettable 1-point min/max history, digital 24-hour temperature chart, and temperature data logging
Adjustable Temperature Range	1°C to 10°C
External alarm connection	State switching remote alarm contacts
Alarms	Adjustable alarm volume, Audible and visual high and low temperature alarms, sensor error alarm, power failure alarm, door ajar alarm, low battery alarm, alarm validation (audible, visual, and remote alarm), alarm mute with ring back, and customizable alarm time delay settings
Controller probe	2 Probes; 1 in air and 1 in sample bottle
Disclaimers	These units are NOT designed for use in environments where volatile/explosive conditions could potentially exist  Indoor use only, +18°C to +26°C (+65°F to +78°F), <70% RH  Specifications are subject to change

**Dimensions**

	<b>Width (in.)</b>	<b>Depth (in.)</b>	<b>Height (in.)</b>	<b>Door Swing (in.)</b>	<b>Total open Depth (in.)</b>
<b>Exterior</b>	30.875"	29"	69.5"	29"	58"
<b>Interior</b>	26.25"	20.875"	58.5"		

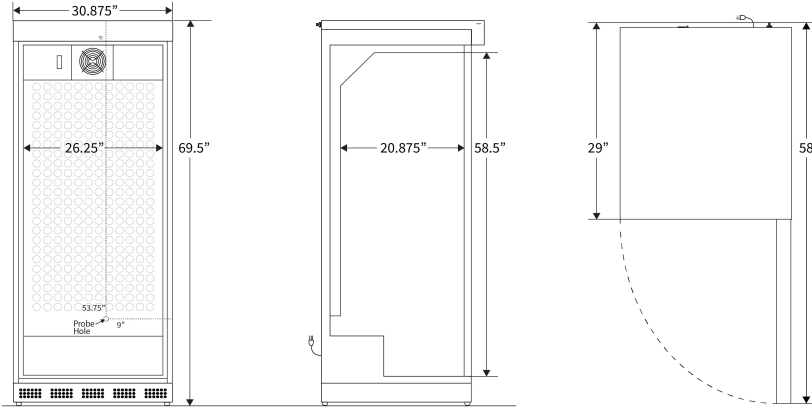

**Contact**

Customer Service

800-521-0754

[sales@labrepc.com](mailto:sales@labrepc.com)