

# Refrigerators and Freezers

Biomedical Freezers | Refrigerator & Freezer Combination  
Laboratory Refrigerators | Pharmaceutical Refrigerators  
Blood Bank Refrigerators | Undercounter Refrigerators and Freezers

[us.panasonic-healthcare.com](http://us.panasonic-healthcare.com)



Discover

pr

# Discovery powered by Panasonic Precision<sup>TM</sup>

[Discovery starts with a dream.](#) A dream to know who we are. A dream to better our lives... Behind every great discovery, there's the technology that made it all possible.

## Introduction

Offer your samples, reagents, and vaccines the advantage of first class refrigeration technology with Panasonic refrigerators and freezers. Our reputation is built on superior performance and reliability with uniform environment, even with higher ambient temperatures and frequent door openings. Panasonic refrigerators and freezers meet the toughest quality standards for performance, ergonomics and return of investment.

We are proud to provide your samples with the ultimate and the most reliable protection, helping cutting-edge research in critical fields like medicine, life sciences, pharmaceuticals, biotechnology, and general industrial use.

# The Industry's Most Complete Refrigeration Solutions

## Table of Contents

Ideal equipment for your refrigeration needs.











## Feature Matrix



## Panasonic Refrigerators & Freezers

Features-Overview	10
Biomedical Freezers	12
Biomedical Refrigerators with Freezers	16
Laboratory Refrigerators	18
Pharmaceutical Refrigerators	23
Blood Bank Refrigerators	26
Undercounter Refrigerators and Freezers	29
<b>Additional Services</b>	
LabAlert	32
Technical Service and Support	34
Validation Services	35

	Precise Uniformity		Energy Savings
	Temperature Stability		Alarms & Monitoring
	Microprocessor based controller		CFC-Free
	Quiet, Reliable Compressors		Service
	Cycle Defrost		Ergonomic Design



# INNOVATION TIMELINE

Laboratory refrigerators and freezers continue to evolve from basic laboratory equipment to sophisticated and precise cold storage equipment. Panasonic has been on the forefront of such advancements with multiple innovations that were first-in-class within this field.

**1966**

Pharmaceutical refrigerators

**1975**

Pharmaceutical refrigerators, MPR 110/210  
Cooled incubator, MIR-150/250/550

**1979**

Blood Bank Refrigerator, MBR-390

**1981**

Compact blood bank refrigerator, MBR-510/1010

**1982**

Large pharmaceutical refrigerators, MPR-510/1010  
Pharmaceutical refrigerator with -30°C freezer, MPR-211F

**1993**

Four-door pharmaceutical refrigerator with  
-30°C freezer, MPR-411F/411FR

**1998**

Pharmaceutical refrigerator, MPR-512/1012  
ISO 14001 (environmental recognition)

## Ideal for vaccine storage

Variation in temperature can drastically affect the effectiveness of vaccines. At the same time, failure to follow proper storage and monitoring practices will result in non-compliance to regulatory standards set by governing agencies. Panasonic refrigeration is designed for specific pharmaceutical and biomedical applications, due to their significant design and precise performance properties.

### Advanced Temperature Controls

Digital temperature sensors inside the refrigerator and controllers are built specifically to maintain a set temperature with precise set point.

### Precise Uniformity

True pharmaceutical grade design, from top-to-bottom, for fast recovery following door opening that leads to stellar uniformity within the chamber.

### Temperature Stability

Efficient temperature recovery properties and minimal temperature fluctuations are maintained around setpoint.

### Alarms and Monitoring

Alarms and temperature monitoring provide quick notifications – both local and remote – of adverse operating conditions.



# Ideal equipment for your refrigeration needs.



## Biomedical Freezers

**-20°C to -30°C**

MDF-U731-PA, MDF-U731M-PA,  
MDF-U5312-PA, MDF-U334-PA



Ideal for long or intermediate-term storage and constructed with high-performance laboratory and clinical-grade refrigeration systems. These freezers are used in medical, biotechnology, and industrial labs for storage of blood components, enzymes, culture media, reagents, specimens, and vaccines.



## Refrigerators & Freezer Combo

**-20°C to -30°C (Freezer)  
2°C to 14°C (Refrigerator)**

MPR-215F-PA, MPR-414F-PA,  
MPR-715F-PA



The biomedical refrigerators with freezer combine high performance refrigeration and monitoring systems with energy efficient cabinet design. One unit with dual temperature zone needs only minimal space, resulting in optimal cost-effective cabinet design.



## Laboratory Refrigerators

**2°C to 23°C**

MPR-721-PA, MPR-721R-PA  
MPR-1411-PA, MPR-1411R-PA



Ideal temperature environment for clinical research, pharmaceutical, and industrial use. Adjustable shelves and wide range setpoint for varying laboratory applications including chromatography and pharmaceutical storage.



## Blood Bank Refrigerators

**4°C**

MBR-107D(H)-PA, MBR-304GR-PA,  
MBR-705GR-PA, MBR-1405GR-PA



Panasonic blood bank refrigerators are designed to create stable, reliable temperature control pre-set to 4°C with precise top-to-bottom temperature uniformity, making them ideal for the storage of whole blood.



## Undercounter Refrigerators & Freezers

**10°C to -20°C**

SR-L6111W-PA, SR-L4110W-PA,  
SR-L4110WSEC-PA, SF-L6111W-PA,  
HF-5017W-PA, HF-5017WSEC-PA



Panasonic undercounters represent stringent quality control processes making them the highest quality laboratory appliance available for demanding standards of clinical, life science, pharmaceutical, biotechnology, and industrial laboratories.



## Pharmaceutical Refrigerators

















**2°C to 14°C**

MPR-514-PA, MPR-514R-PA,  
MPR-1014-PA, MPR-1014R-PA,  
MPR-S313-PA



The slim design and optional sliding shelves give Pharmaceutical refrigerators an ergonomic advantage. These refrigerators offer a complete, integrated solution for the growing requirements of strict and exact storage temperatures for storage of pharmaceuticals, medicines and temperature-sensitive biologicals.

# Feature Matrix

	BIOMEDICAL FREEZERS	BIOMEDICAL REFRIGERATORS WITH FREEZERS	LABORATORY REFRIGERATORS	PHARMACEUTICAL REFRIGERATORS	BLOOD BANK REFRIGERATORS	UNDERCOUNTER REFRIGERATORS AND FREEZERS
OPERATING RANGE	-30°C to -20°C	-30°C to 20°C	2°C to 23°C	2°C to 14°C	2°C to 14°C	-20°C to 10°C
SIZE RANGE	 9.7 Cu.Ft	 6.2 Cu.Ft	 24 Cu.Ft	 12 Cu.Ft	 2.8 Cu.Ft / 10.6 Cu.Ft	 6 Cu.Ft
	 17 Cu.Ft.	 12 Cu.Ft.	 48 Cu.Ft.	 17 Cu.Ft.	 21.8 Cu.Ft.	 4.9 Cu.Ft.
	 23 Cu. Ft.	 14.7 Cu. Ft.		 36 Cu. Ft.	 45.9 Cu. Ft.	 5.4 Cu. Ft.
OPERATING MODE (AUTOMATIC)	✓	✓	✓	✓	✓	✓
OPERATING MODE (MANUAL)	✓	✓				
<b>MAJOR APPLICATIONS</b>						
GENERAL STORAGE	✓	✓	✓	✓		✓
REAGENTS AND KITS	✓	✓	✓	✓		
CULTURE MEDIA	✓	✓	✓	✓		
BIOLOGICALS		✓	✓	✓		
ENZYMES	✓	✓	✓	✓		✓
VACCINES	✓	✓				
PATIENT MEDICATION		✓		✓		✓
WHOLE BLOOD					✓	
PLASMA	✓	✓				
SHELF LIFE TESTING	✓	✓	✓			
CHROMATOGRAPH APPARATUS		✓	✓	✓		
TEST SAMPLES	✓	✓	✓	✓		✓





# Vaccine Specific Preservation

Panasonic offers a selection of Biomedical refrigerators and freezers that include significant design and performance properties, which differentiate them from conventional household refrigerators. These are designed for specific vaccine storage applications, making them ideally suited for use in clinics, hospitals, retail pharmacies, and laboratories to store vaccines.

## Comparison with Domestic Refrigerators

PRODUCT CHARACTERISTICS	MPR SERIES	DOMESTIC REFRIGERATOR
CFC-FREE, RELIABLE TEMPERATURE CONTROL NOT AFFECTED BY AMBIENT TEMPERATURE	✓	⊗
DIGITAL DISPLAY OF CHAMBER TEMPERATURE	✓	⊗
PRECISE TEMPERATURE SETTING OF CHAMBER WITH MICROPROCESSOR CONTROL	✓	⊗
DIGITAL VARIABLE TEMPERATURE CONTROL OF REFRIGERATOR (2°C TO 14°C)	✓	⊗
VARIABLE TEMPERATURE CONTROL OF FREEZER (-20°C TO -30°C)	✓	Max/Mid/Min
UNIFORM TEMPERATURE AT ALL SHELF LEVELS	✓	⊗
SEPARATE OPERATION OF REFRIGERATOR AND FREEZER	✓	⊗
WINDOW FOR VIEWING	✓	⊗
OPTIMIZED SPACE DEDICATED TO STORAGE	✓	⊗
ACCESS PORT	✓	Some Models Yes
TEMPERATURE RECORDER (OPTIONAL)	✓	⊗
DOOR AJAR TRIGGERS INDICATOR LIGHT AND AUDIBLE ALARM (OPTIONAL)	✓	Some Models Yes
IRREGULAR TEMPERATURE TRIGGERS ALARM (OPTIONAL)	✓	⊗
REMOTE ALARM TERMINAL	✓	⊗
SET TEMPERATURE DEVIATION	✓	⊗
SELF DIAGNOSTIC FUNCTION	✓	⊗
UNIQUE CYCLE DEFROST / AUTOMATIC DEFROST SYSTEM	✓	⊗
CONDENSATE EVAPORATOR	✓	✓





# Features - Overview

Panasonic offers a selection of Refrigerators and Freezers that include significant design and performance properties. These units are more suitable for pharmacy and biomedical use than conventional household refrigerators and freezers.



## Precise Uniformity with Panasonic Design

Compressors are specifically designed for demanding scientific and laboratory storage, offering precise uniformity throughout the chamber.



## Alarms & Monitoring

Comprehensive setpoint, alarm monitoring, and diagnostic functions are supervised by the Panasonic-built microprocessor controller with digital display of all input/output function.



## Temperature Stability

Forced Air Circulation technology quickly restores temperature uniformity following routine door openings. In addition, Panasonic cycle defrost (in most units) initiates only as required, maintaining internal temperature uniformity during the process.



## Energy Savings

Always a leader in environmentally friendly technology, Panasonic refrigerators use commercially available HFC refrigerants and CFC-free insulation. Panasonic is committed to developing green technologies that provide energy efficiency, resulting in lower operational costs with less impact on the environment.



## Cycle Defrost Function for Auto Defrost Units

Panasonic's Cycle Defrost system design ensures that defrost occurs only when necessary and not based on time, like other competitive units. This system runs automatically so there is no need to turn off power for defrosting. Temperature increase during defrost is minimal with no temperature spikes. The evaporation heater also adds additional protection against decrease in cabinet temperature, which can be caused by low ambient temperature.

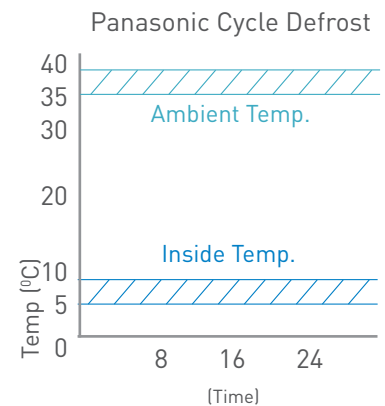

## Cycle Defrost Function Data

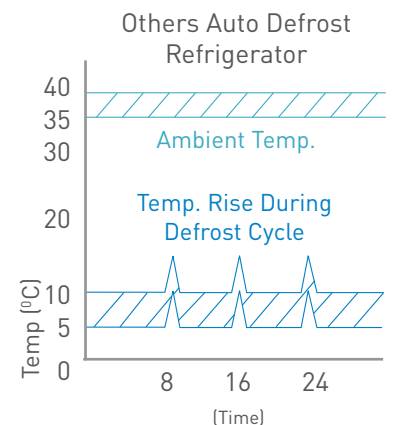
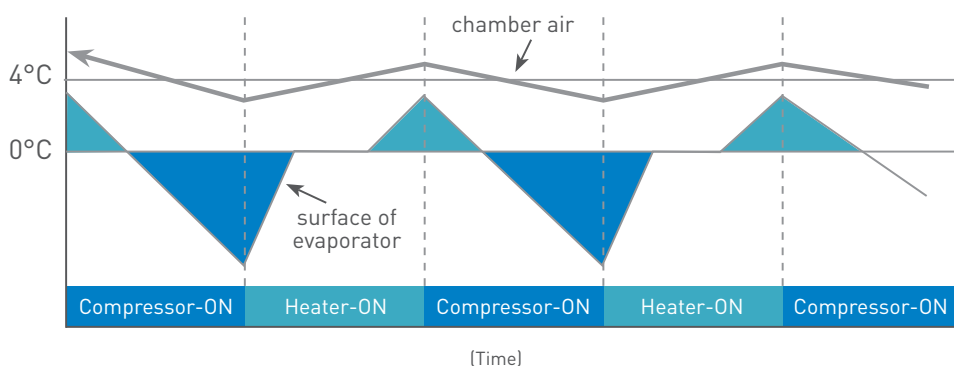



### Microprocessor based controller

Panasonic Microprocessor based controller manages setpoints and actual conditions to provide the highest level of security for the stored products.

#### Buzzer stop key:

To silence the audible alarm, press this key. The remote alarm is also silenced by pressing this key.

#### Set key:

Defaults to previously set temperature when required.

#### Door check indicator:

The red LED lamp is lit when the outer door is opened.

#### Alarm lamp:

This lamp is flashed when the audible alarm is activated.

#### Interior Light Switch

Enables interior lightening system (on designated models).



#### Digital temperature indicator:

This indicator shows the present chamber temperature or set.



# Biomedical Freezers

Panasonic MDF series biomedical freezers are designed for long or intermediate-term storage at temperatures as low as  $-30^{\circ}\text{C}$ . Constructed with high-performance laboratory and clinical-grade refrigeration systems, these freezers are used in medical, biotechnology, and industrial labs for storage of blood components, enzymes, culture media, specimens, vaccines etc.

**Models:** MDF-U334-PA, MDF-U5312-PA, MDF-U731/731M-PA



## Performance Data -MDF-U731-PA

Pull-down characteristics under no-load condition

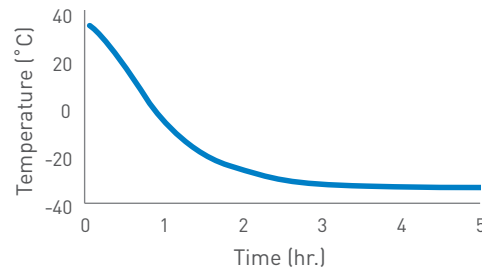

Pull-up characteristics during power failure

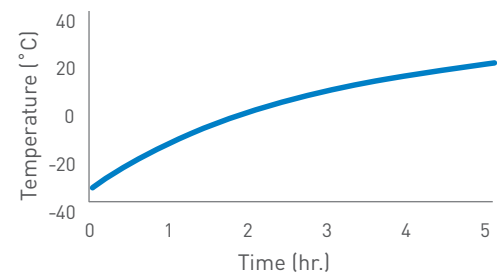

### General Purpose Storage, Maintenance-Free (Auto-Defrost Models)

Storage at  $-30^{\circ}\text{C}$  with auto-defrost and consistent temperature control below  $-20^{\circ}\text{C}$  during defrost cycle. Maintenance-free storage with no end user intervention to defrost unit and clean up condensate. Precision temperature uniformity throughout chamber due to forced air circulation with dual fans.

## Performance Data -MDF-U334-PA & MDF-5312-PA

Pull-down characteristics under no-load condition

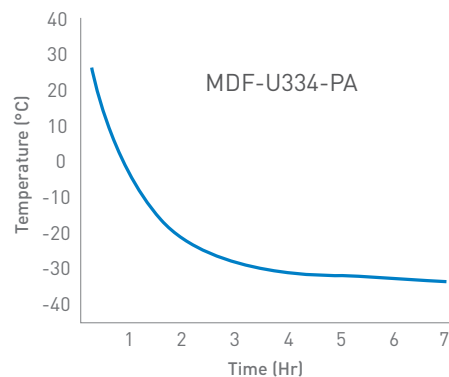

Pull-down characteristics during power failure

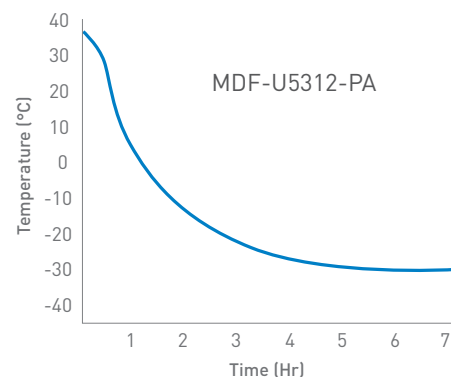

### Enzyme and Biologics Preservation (Manual Defrost Models)

Uniform temperatures are maintained throughout the chamber using shelf freezing construction. Since there is no defrost cycle, the inner chamber temperature offers outstanding uniformity and stability without temperature spikes. Standard door lock for an independent padlock ensure extra safety.





**Microprocessor Controls:**

Comprehensive setpoint, alarm, monitoring, and diagnostic functions supervised by the MDF Series microprocessor controller with digital display of all input / output function.

**Enzyme Storage Freezer Bins (MDF-U731M-PA Only):**

The optional full storage system, Model #: 730MFB creates a flexible and convenient inventory system for enzymes and many other types of samples. The total system includes 14 storage bins and additional wire shelving.

**Freezer Temp: Bins vs. No Bins**

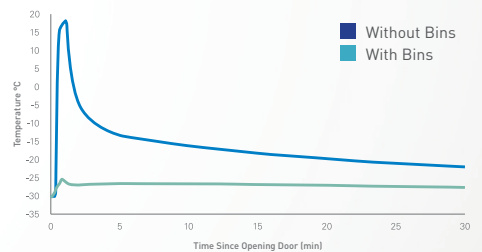

Door open to 90° angle for 30 seconds



**Sample Storage Security:**

Keyed door lock and integrated padlock hasp are standard features.



**Quiet Operation:**

The MDF Series has energy-efficient refrigeration design with no noisy condenser fan. In combination with low dB level compressor, this unit is uniquely quiet and perfect for in-lab installations.



**Adjustable Shelving System:**

Four adjustable wire shelves with over 100 pound capacity each allowing for flexible material storage configurations.

# Specifications

MODEL NUMBER	MDF-U5312-PA	MDF-U334-PA	MDF-U731-PA	MDF-U731M-PA
EXTERIOR DIMENSIONS (W X F-B X H)	31.5" x 30.4" x 70.9" 804 x 772 x 1802 mm	24.2" x 27.9" x 63.8" 614 x 709 x 1620 mm	30.3" x 32.7" x 77.0" 770 x 830 x 1955 mm	30.3" x 32.7" x 77.0" 770 x 830 x 1955 mm
INTERIOR DIMENSIONS (W X F-B X H)	25.9" x 23.9" x 50.1" 658 x 607 x 1272 mm	19.3" x 19.1" x 50.8" 490 x 485 x 1290 mm	25.6" x 28.0" x 53.9" 650 x 700 x 1370 mm	25.6" x 27.5" x 59.8" 650 x 700 x 1520 mm
CAPACITY	17.0 cu.ft. 482 L	9.7 cu.ft. 274 L	22.0 cu.ft. 623 L	24.4 cu.ft. 690 L
CONTROL RANGE	-20°C to -30°C, with memory backup		-20°C to -35°C	-18°C to -30°C
DEFROST SYSTEM	Manual, defrost button on display		Automatic Defrost	Manual Defrost
STORAGE	Top: 6 small baskets (3 fixed evaporator shelves) Bottom: 4 large baskets (1 evaporator shelf and bottom)	Top: 4 large baskets (446 x 369 x 220 mm) Bottom: 1 small basket (487 x 221 x 155 mm)		
ACCESS PORT	30 mm diameter, rear	30 mm mid left wall	Diameter 30 mm (left) / Diameter 20 mm (top)	
COOLING SYSTEM	Hermetic rotary compressor, ½ HP	Hermetic rotary compressor ¼ HP	½ HP (400W), Hermetic Rotary Type	
REFRIGERANT	R-404A (HFC)	R-134a (HFC)	Environmentally friendly, HFC refrigerant (R-404A)	
VISUAL AND AUDIBLE ALARM SYSTEM	High/low temperature alarm (SV ±5°C to ±15°C adjustable with ring-back function); Power Failure; Remote alarm contacts (N.O./N.C.)		High/Low temperature alarm, door ajar alarm, power failure, remote alarm contacts, memory backup	
CALIBRATION	Zero adjustment via control panel			
ELECTRICAL REQUIREMENTS	115V, 60 Hz, 1 phase, 2.1 amps running, NEMA 5-15P plug		115V, 60 Hz, 15 Amp breaker, NEMA 5-15P Plug	
WEIGHT	Net Unit Weight: 295 lbs / 134 kg	Net Unit Weight: 178 lbs / 81 kg	Net Unit Weight: 335 lbs / 152 kg	
SECURITY	Display Keylock, Keyed outer doors, Standard paddlock hasp per door	Display Keylock, Keyed outer doors, Standard paddlock hasp	Display Keylock, Keyed outer doors, Standard paddlock hasp	



MDF-U334-PA



MDF-U731M-PA

# Dimensional Drawings

**MDF-U5312-PA**  
(mm)

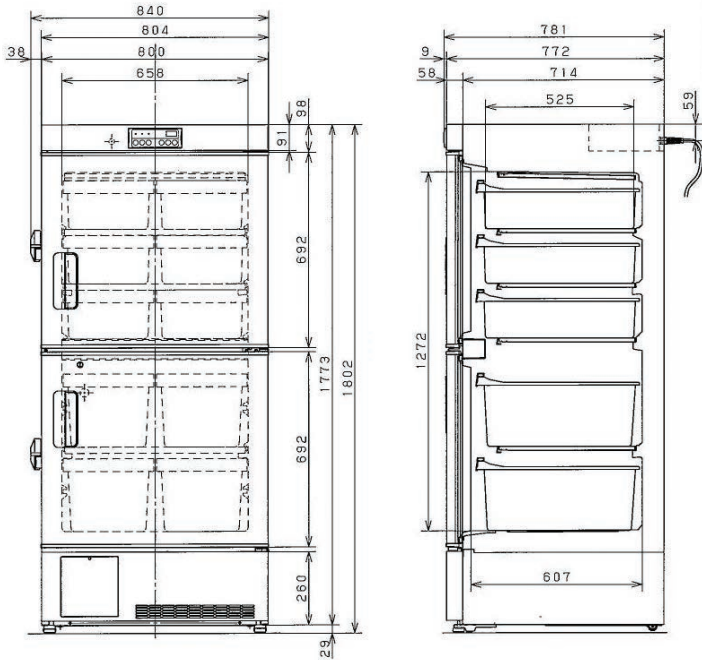

**MDF-U334-PA**  
(mm)

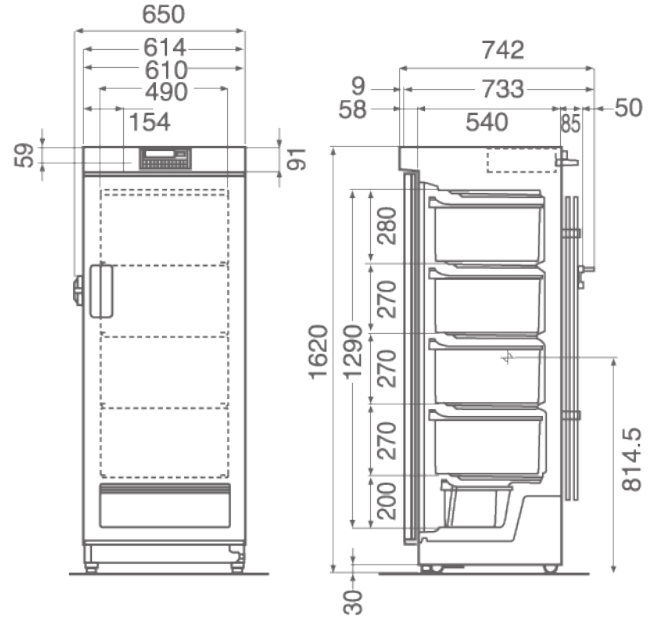

**MDF-U731-PA**  
(mm, in)

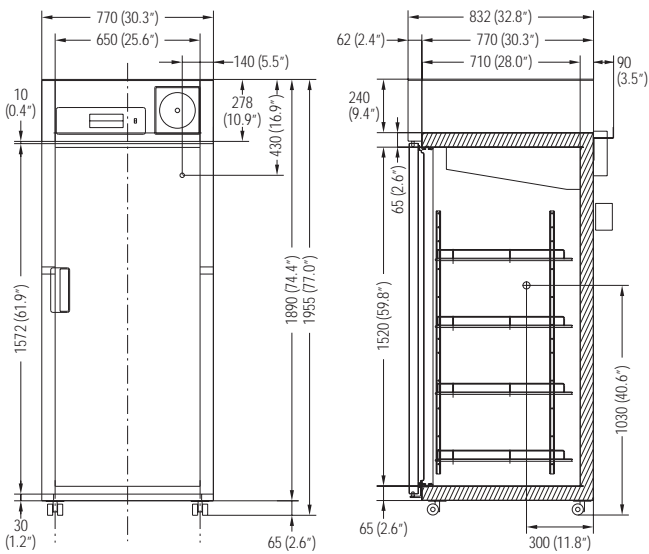

**MDF-U731M-PA**  
(mm, in)

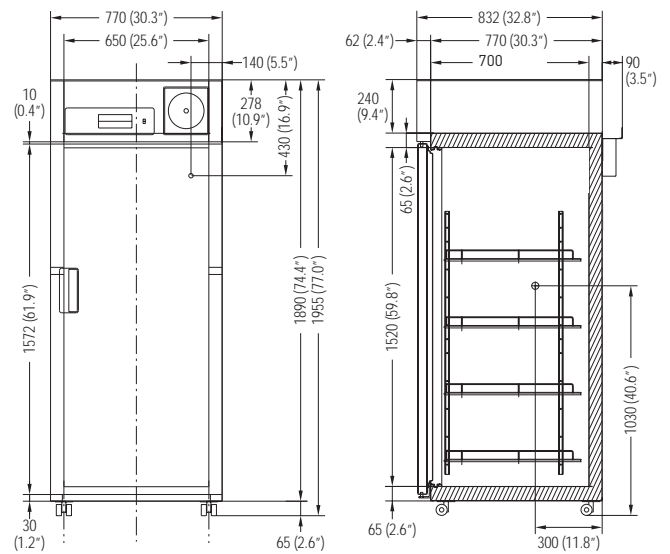

# Refrigerator & Freezers Combo

The MPR Series biomedical refrigerators with freezer combine high performance refrigeration, alarm monitoring systems with energy efficient cabinet design. One unit with dual temperature zone needs only minimal space. The two door design reduces air loss during door openings.

**Models:** MPR-215F-PA, MPR-414F-PA, MPR-715F-PA



## Energy Savings

Energy-saving storage solutions for uniformity and reliability with dual temperature zones.

## Temperature Uniformity

Refrigeration systems designed for precise and stable vaccine and biological storage.

	MPR-215F-PA		MPR-414F-PA		MPR-715F-PA	
MODEL	Refrigerator	Freezer	Refrigerator	Freezer	Refrigerator	Freezer
EFFECTIVE CAPACITY	6.2 cu. ft. 176 L	1.4 cu. ft. 39 L	12.0 cu. ft. 340 L	2.9 cu. ft. 82 L	14.7 415 L	6.2 176 L
EXTERNAL DIMENSIONS (W X F-B X H)	21.3" x 21.9" x 70.6" 540 x 557 x 1794 mm		31.5" x 23.6" x 71.0" 800 x 600 x 1805 mm		35.4" x 28.1" x 75.2" 900 x 715 x 1910 mm	
WEIGHT	189 lbs. 86 kg		277 lbs. 126 kg		371 lbs 168 kg	
EXTERIOR	Polyester resin finish baked on zinc galvanized steel					
INTERIOR	Styrene resin	Colored aluminum plate	Stainless steel	Colored aluminum plate	PCM Painted Steel	
INSULATION	CFC-Free rigid polyurethane foamed in place					
TEMPERATURE RANGE	2°C to 14°C Ambient temperature: [-5°C to 30°C, no load]	-20°C to -30°C Ambient temperature: [-5°C to 30°C, no load]	2°C to 14°C Ambient temperature: [-5°C to 35°C, no load]	-20°C to -30°C Ambient temperature: [-5°C to 35°C, no load]	2°C to 14°C Ambient temperature: [-5°C to 30°C, no load]	-20°C to -30°C Ambient temperature: [-5°C to 30°C, no load]
TEMPERATURE CONTROL	Microprocessor LED Display					
COOLING METHOD	Fan-Forced air circulation	Direct Cooling (manual defrost)	Fan-Forced air circulation	Direct Cooling (manual defrost)	Fan-Forced air circulation	Direct Cooling (manual defrost)
COMPRESSOR	55W	55W	160W	160W	150W	200W
REFRIGERANT	R-134A (HFC)					
SHELVES	5 (44 lbs / shelf)	1 (22 lbs / shelf)	Large: 2 (55 lbs / shelf) Small: 3 (33 lbs / shelf)	1 (22 lbs / shelf)	3 (55 lbs / shelf)	2 (33 lbs / shelf)
ACCESS PORT	30 mm (left)	30 mm (left)	30 mm (rear)	30 mm (rear)	30 mm (rear)	30 mm (rear)
CASTERS	4 casters with 2 adjustable leveling feet					
ALARM AND SAFETY	High/low temperature alarm, Door ajar alarm, Memory back up during power failure Self-diagnostics, remote alarm contacts (N.O./N.C., DC30V, 2A). Door key lock. Critical component lifespan alarm					
VOLTAGE	115V / NEMA 5-15					
OPTIONS	<ul style="list-style-type: none"> <li>2-pen type circular temperature recorder (MTR-C955)</li> <li>LabAlert Wireless Monitoring</li> </ul>		<ul style="list-style-type: none"> <li>2-pen type circular temperature recorder (MTR-C955)</li> <li>Drawers for the bottom left compartment (MPR-41R)</li> <li>LabAlert Wireless Monitoring</li> </ul>		<ul style="list-style-type: none"> <li>2-pen type circular temperature recorder (MTR-C955)</li> <li>Power failure alarm (MPR-48B)</li> <li>LabAlert Wireless Monitoring</li> </ul>	

MPR-715-PA



#### Microprocessor Controls:

- NEW energy saving LED lighting.
- Microprocessor controller and interior forced air circulation
- Integrated alarm functions



#### Cycle Defrost:

Unique cycle defrost (refrigerator only) initiates only as required and maintains internal temperature uniformity, without fluctuation due to a defrost cycle.

#### Refrigeration Systems

Separate refrigeration systems and compressors allow differential control of individual refrigerator and freezer compartments, allowing freezer section to maintain temperatures as low as -30°C.

**The MPR series combo units have two separate specially designed compressors and offer quiet operation.**



#### Cabinet Construction:

- Double-pane windows with heat reflection film reduces the condensation.
- Calibration adjustment through the control panel is available.



# Laboratory Refrigerators

Panasonic Laboratory refrigerators provide stable and reliable refrigerated environment for carrying laboratory requirements, making them ideal for clinical research, pharmaceutical, and industrial use. Adjustable shelves and wide range setpoint for varying laboratory applications, including chromatography and pharmaceutical storage.

**Models:** MPR-721-PA, MPR-721R-PA, MPR-1411-PA, MPR-1411R-PA



## Easy-to-Manage Layout with Large Capacity

The interior layout flexibility of the MPR series refrigerators due to adjustable shelves make them ideal for running experiments that require changeable shelf configurations. The spacious interiors with multiple capacity refrigerators allow for accommodation of column chromatography apparatus or large volumes of reagents, test samples, and biologicals.

## Relationship between chamber temperature and ambient temperature

(Comparison with standard domestic refrigerators)

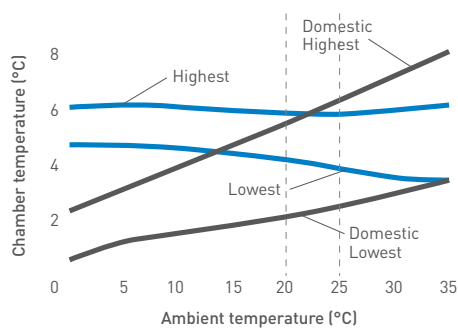

- MPR-1411R-PA: Set at 5°C  
100mm (3.9 inches) inside of drawers
- Standard domestic refrigerator

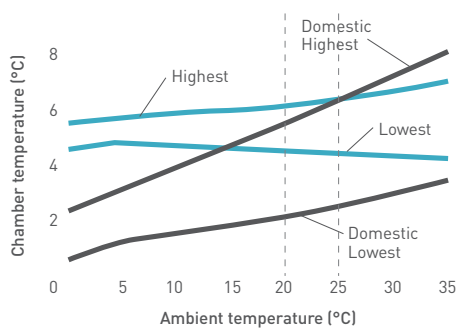

- MPR-1411-PA: Set at 5°C  
100mm (3.9 inches) inside of shelves
- Standard domestic refrigerator





# Alarms & Safety Features

FEATURE	TRIGGER	TYPE OF ALARM/RESPONSE
HIGH TEMPERATURE ALARM	2°C to 14°C (selectable) above setpoint	Flashing LED & audible alarm after 15 minutes
LOW TEMPERATURE ALARM	2°C to 14°C (selectable) below setpoint & 0°C or lower	Flashing LED & audible alarm
TEMPERATURE LOCK	Lock ON	Set temperature and alarm points cannot be altered
MEMORY BACKUP	Power failure	Memory of settings
DOOR AJAR	Door not closed	Door ajar lamp ON, adjustable audible alarm from 1 to 15 minutes
SELF DIAGNOSTICS	Sensor failure and fan or compressor abnormality	Error code shown
REMOTE ALARM CONTACTS	N.O. and N.C. contact available for hook up to an auxiliary alarm system	—
TEMPERATURE RECORDER	Optional, Model #MTR-C954, 7-day 6" circular chart or touch panel digital temperature recorder	—



## Performance Data

**MPR-1411-PA Pull-down characteristics (no-load)**

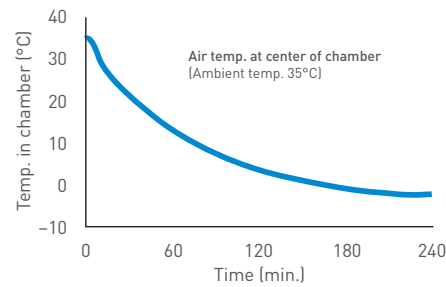

**MPR-1411-PA Power-off, Warm-up characteristics (no-load)**

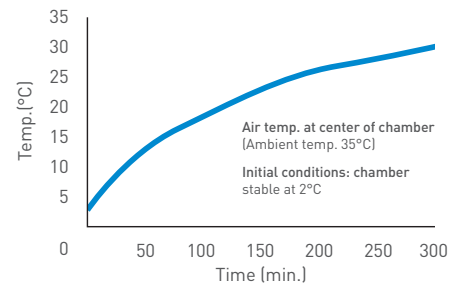

### Wide Settable Temperature Range

With a temperature range of 2°C to 23°C, Panasonic's MPR series refrigerators are ideally suited for tests that require a stable, cool temperature, or general cold storage.



### Large Fans:

The quiet 4.7" diameter fan ensures an even temperature throughout the cabinet. (MPR-1411R-PA models have a double flow system with two fans). As a consequence, heat spots from powered test apparatus are minimized while recovery characteristics are maintained.

MPR-1411-PA

MPR-721-PA



### Easy Access Front Control Panel:

Large LED display of actual temperature with intuitive touch pad setting makes operation simple.

### Drawer Type Shelves:

The "R" models are fitted with steel pull-out drawers. With a profile of 3.9 inches (100mm) and 20.8 inches (530mm). Front-to-back, these drawers are deep enough to hold large bottles or reagent kits. They also allow convenient, space-efficient storage and management of patient medications.



### Adjustable shelves:

The shelves can be arranged to accommodate a tall apparatus, such as fraction collectors. These shelves are deep by 24.4 inches (620mm) front-to-back. and strong enough to withstand a load of 110lbs. For the MPR-721, shelves can hold a load of 110 lbs, while the shelves of the MPR-1411 withstand 88 lbs.

### User Friendly Design & Double Door/Single Door Function:

The broad, solid frames with effective gaskets ensure excellent temperature stability, while double-pane glass windows offer an excellent view of the interior. Optional panels are available to block out light.



	MPR-1411-PA	MPR-1411R-PA	MPR-721-PA	MPR-721R-PA
EXTERIOR DIMENSIONS (W X F-B X H)	56.7" x 32.67" x 76.8"	56.7" x 32.67" x 76.8"	30.3" x 32.67" x 77.0"	30.3" x 32.67" x 77.0"
VOLUME (CU.FT.)	48.2	48.0	24.2	23.7
EXTERIOR FINISH	Acrylic finish baked on zinc galvanized steel			
INTERIOR FINISH	Acrylic finish baked on zinc galvanized steel			
DOORS	2x double pane glass doors, self closing		1x double pane glass doors, self closing	
INSULATION	CFC-free rigid foamed-in-place polyurethane			
ACCESS PORT	3 x 30 mm (2 in sides, 1 in cabinet top)			
LOCKS	2x cylinder type (each door)		1x cylinder type	
SHELVES	8 (565w x 604d mm)	—	4 (565w x 604d mm)	—
DRAWERS	—	10 (550w x 530d mm)	—	5 (550w x 530dmm)
COOLING METHOD	Forced air circulation with double fan		Forced air circulation with single fan	
COMPRESSOR	250W hermetic rotary		200W hermetic rotary	
EVAPORATOR	Forced air			
CONDENSER	Fin tube type		Wire tube type, Filter-less design	
REFRIGERANT	R-404a(HFC)		R-134a(HFC)	
DEFROST METHOD	Intelligent forced type (cycle defrost system), full automatic hot pipe for automatic condensate evaporation for condensate water			
TEMPERATURE CONTROL	Microprocessor controlled. 2°C to 23°C temperature range can be configured to 1°C increments			
TEMPERATURE DISPLAY	Digital type (1°C resolution)			
SAFETY FEATURES	High temperature protection circuit, low temperature protection circuit, temperature lock, self diagnostics, memory backup (nonvolatile memory)			
HIGH TEMPERATURE ALARM	When temperature 5°C or more above set level, flashing LED & buzzer after adjustable delay		Flashing lamp when temperature 5°C or more above set point, buzzer after adjustable delay	
LOW TEMPERATURE ALARM	When interior temperature drops to 0°C or lower, flashing LED & buzzer			
DOOR AJAR ALARM	Flashing lamp, adjustable delay (1-15min)			
INTERIOR LAMP	40W x 1, fluorescent lamp		20W x 1, fluorescent lamp	
POWER SOURCE				
VOLTAGE	115v 60Hz NEMA 5-15P (15 A)			
NOMINAL BTU OUTPUT	1298btu		1159btu	
OPTIONAL ACCESSORIES				
CHART RECORDER	Circular Chart Temperature Recorder, 7 Days		MTRC954	
WIRELESS MONITORING	LabAlert Cloud / App-based monitoring system			
TOUCH-SCREEN TEMPERATURE	Full Color Touch-Screen Digital Display		FT-560SN	
4-20MA OUTPUT	Independent Analogue Output		MTR-420MAC	
RS-485 OUTPUT	Independent Digital Output		MTR-480-PW	
BATTERY KIT	Batter Kit for power failure audible alarm		MPR-48B-PW	

# Dimensional Drawings

MPR-1411-PA  
(in)

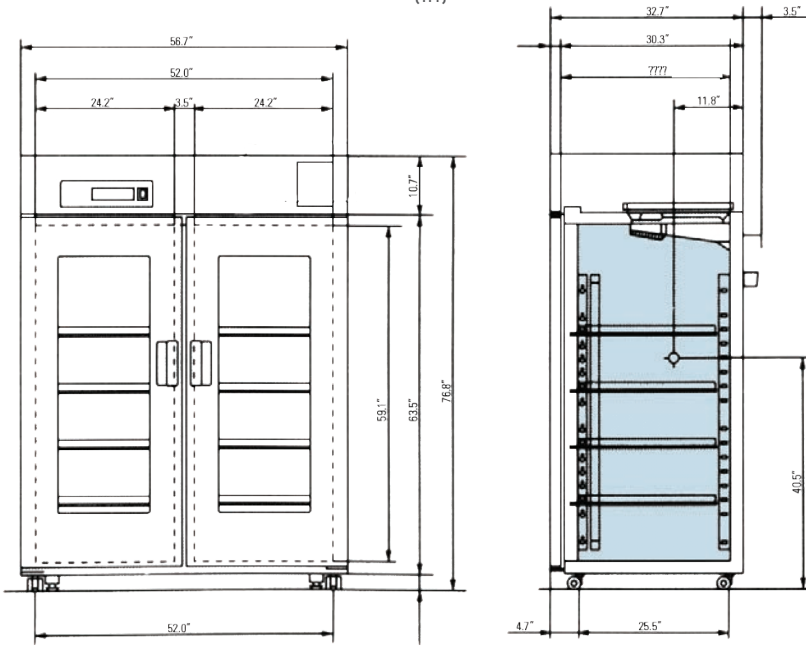

MPR-721-PA  
(in)

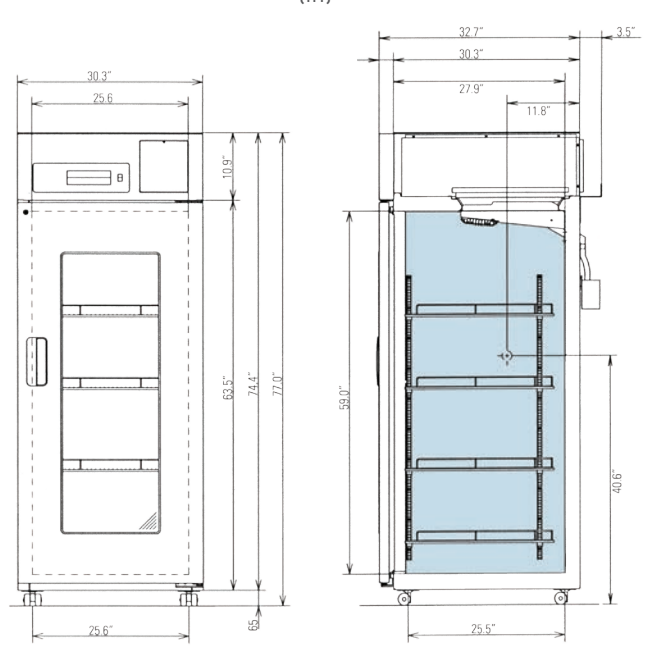

MPR-1411R-PA  
(in)

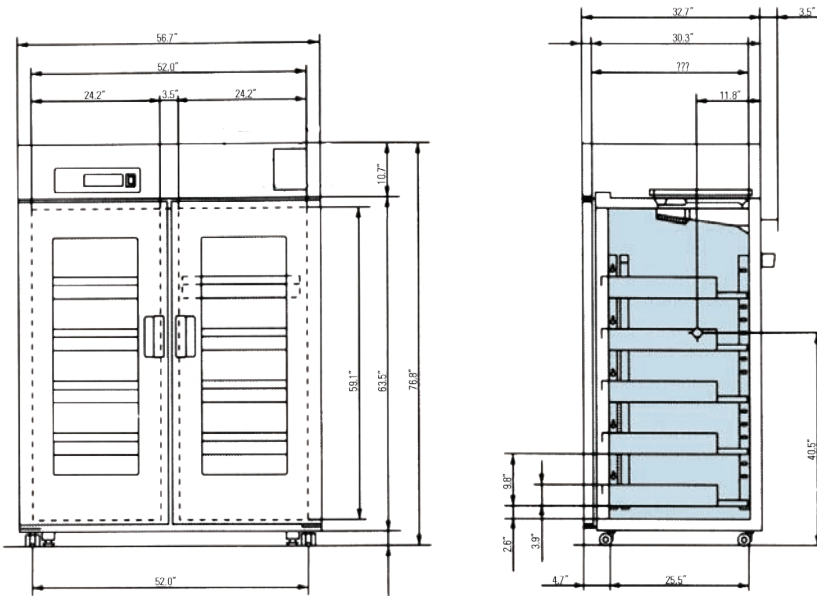

MPR-721R-PA  
(in)

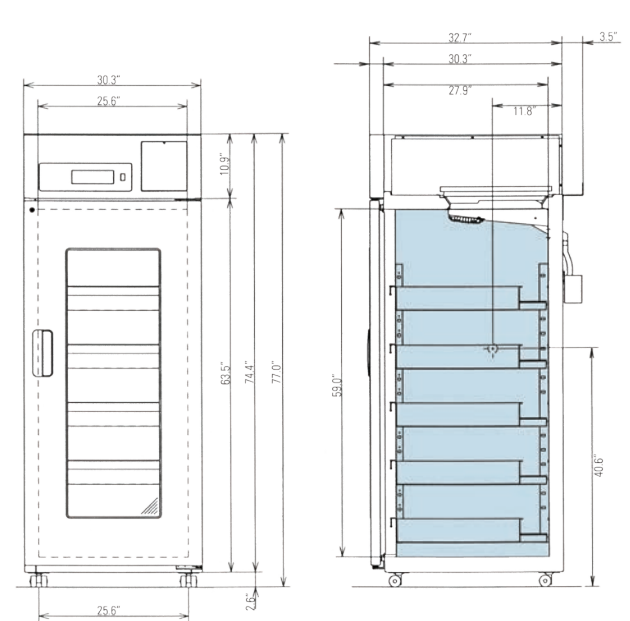

# Pharmaceutical Refrigerators

Panasonic Pharmaceutical Refrigerators offer a complete and integrated solution for the increased requirements of strict and exact storage temperatures for pharmaceuticals, medicines, vaccines, and other temperature sensitive biologicals. The slim front-to-back design and optional sliding shelf allows for an easy retrieval of your product.

**Models:** MPR-514-PA, MPR-514R-PA, MPR-1014-PA, MPR-1014R-PA, MPR-S313-PA



## Effective Temperature Control

A thermistor sensor monitors temperature inside the chamber. Microprocessor and electronic temperature controls ensure that the set temperature is maintained. Even with frequent door openings, the circulation fan provides rapid temperature adjustment for a highly reliable, stable preservation environment that is unaffected by ambient temperature.

## Ergonomic Design

The ergonomic design of the MPR series refrigerators provides a clear view of stored items through the large framed windows. The slim profile allows for easy retrieval of your products, without the concern for swinging door clearances. Users can choose from two types of interior shelving to suit their needs.

## Uniform Storage Temperature – Cycle Defrost

Defrosting is performed automatically during compressor “off” cycles by sensing frost levels. This way defrosting is performed only when required, further protecting the contents against unnecessary temperature rise.

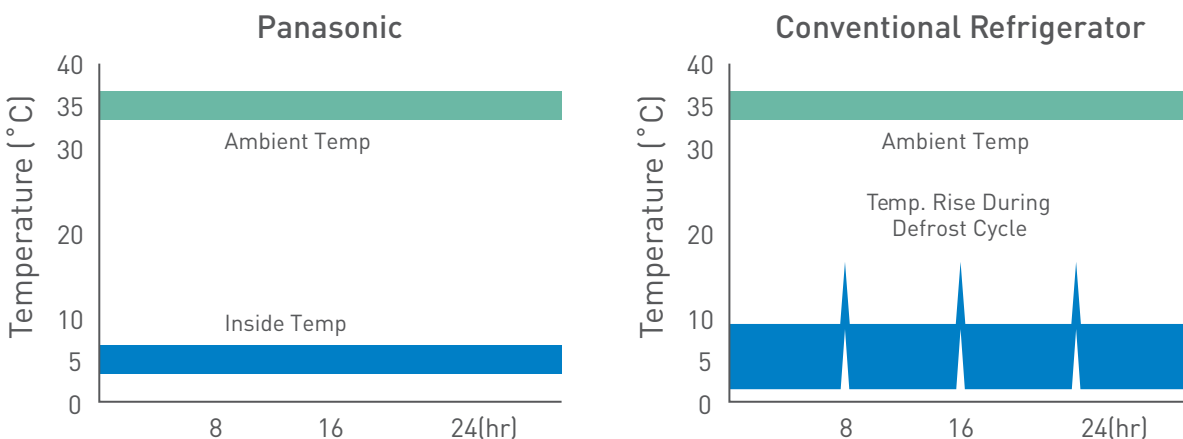





### Visual LED Alarm Alerts

Audible and flashing LED visual alarms alert you to the unlikely event of either a high or low temperature condition. An over-shooting prevention circuit automatically switches off the fan motor or heater, if the inside temperature rises abnormally.

### Easy to read digital display

Temperature readings are displayed in gradients of 1°C for configurable temperatures ranging from 2° to 14°C.

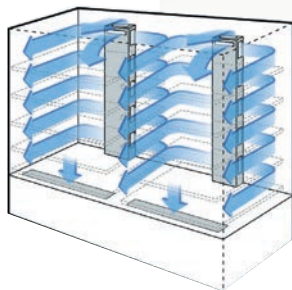

### Plenums Direct Airflow:

Panasonic's plenum design features uniform cold air flow distribution throughout the chamber to ensure temperature uniformity – essential for validated storage requirements.



### Cabinet Construction:

View window door design with protective film for safety. Key locked doors. Black out glass design is optional.

# Specifications

MODEL NUMBER	MPR-S313-PA	MPR-514-PA	MPR-514R-PA	MPR-1014-PA	MPR-1014R-PA
EXTERIOR DIMENSIONS W X F-B X H	31.5" x 17.7 x 70.9" 800 x 450 x 1800 mm	35.4" x 23.6" x 70.5" 900 x 600 x 1790 mm	35.4" x 23.6" x 70.5" 900 x 600 x 1790 mm	70.9" x 23.9" x 70.5" 1800 x 600 x 1790 mm	70.9" x 23.9" x 70.5" 1800 x 600 x 1790 mm
VOLUME	12.0 cu.ft. / 340 L	17.2 cu.ft. / 489 L	17.2 cu.ft. / 486 L	36.5 cu.ft. / 1037 L	36.5 cu.ft. / 1037 L
WIRE SHELVES	adjustable	adjustable	½ adjustable, ½ roll-out	adjustable	½ adjustable, ½ roll-out
EXTERIOR	Baked on acrylic finish galvanized steel	Baked on acrylic finish galva- nized steel	Baked on acrylic finish galvanized steel	Baked on acrylic finish galvanized steel	Baked on acrylic finish galvanized steel
INTERIOR	Stainless steel	Stainless steel	Stainless steel	Stainless steel	Stainless steel
OUTER DOORS	4 sliding doors. Double paned glass window	2 sliding doors. Double paned glass window	2 sliding doors. Double paned glass window	2 sliding doors. Double paned glass window	4 sliding doors. Double paned glass window
OUTER DOOR LOCK	2 lock, 2 keys	1 lock, 2 keys	1 lock, 2 keys	1 lock, 2 keys	1 lock, 2 keys
SHELVES & SLIDING RACKS	Rigid wire with clear coat finish	5 polyester coated wire shelves Load: 110 lbs per shelf	5 polyester shelves + 5 polyester coated sliding shelves Load: 44 lb per shelf	5 polyester coated wire shelves Load: 110 lbs per shelf	5 polyester shelves + 10 polyester coated sliding shelves Load: 110 lbs per shelf
COOLING METHOD	Forced cool air circulation	Forced cool air circulation	Forced cool air circulation	Forced cool air circulation	Forced cool air circulation
INTERIOR LIGHTING	L.E.D	Fluorescent	Fluorescent	Fluorescent	Fluorescent
DEMAND DEFROSTING	Fully Automatic Cycle Defrost	Fully Automatic Cycle Defrost	Fully Automatic Cycle Defrost	Fully Automatic Cycle Defrost	Fully Automatic Cycle Defrost
POWER REQUIREMENTS AND POWER CONSUMPTION	115V/60 Hz/3.8 kWh/Day NEMA 5-15P Plug,	115V/60 Hz/6.43 kWh/day, NEMA 5-15P Plug	115V/60 Hz/6.43kWh/day NEMA 5-15P Plug	115V/60 Hz/8.74 kWh/ Day NEMA 5-15P Plug	115V/60 Hz/8.74kWh/ Day NEMA 5-15P Plug
NET WEIGHT	198.4 lbs / 90 kg	310 lbs / 142 kg	324 lbs / 142 kg	555 lbs / 252 kg	555 lbs / 252 kg

## Accessories

### MPR-514/R-PA & MPR-1014/R-PA

MODEL NUMBER	DESCRIPTION
MTR-C954	Temperature Recorder   7 day, 6 inch circular chart
MPR-48B	Alarm battery back-up
LabAlert™	Wi-Fi or Wireless Monitoring System

### MPR-S313-PA

MODEL NUMBER	DESCRIPTION
MTRC954	Temperature Recorder 7 day, 6 inch circular chart
KM-RPP01BB1W	Remote Alarm Contacts with audible power failure alarm
LabAlert™	App/Cloud based Wi-Fi or Wireless Monitoring System



# Blood Bank Refrigerators

Panasonic blood bank refrigerators provide the ideal +4°C environment for safe and reliable storage of whole blood. These are designed to create stable, reliable temperature control pre-set to 4°C with precise top-to-bottom temperature uniformity. These refrigerators conform to AABB criteria with a highly efficient compressor that provides superior temperature recovery, rapid cooling, and quiet performance.

**Models:** MBR-107D(H)-PA, MBR-304GR-PA, MBR-705GR-PA, MBR-1405GR-PA



## Microprocessor Control

Microprocessor controlled defrost system designed with thermal sensors and heaters on the evaporator, all under precise microprocessor control.

## Temperature Uniformity

Multi air-flow plenum system ensures excellent temperature uniformity in larger capacity models. (MBR-705GR-PA, MBR-1405GR-PA).





### Audible and flashing LED Visual alarms

Audible and flashing LED visual alarms with remote alarm sounds, in case of power failure, high or low temperature condition, or during any thermal sensor abnormality.



### Stable Temperature Control

Two thermistor sensors constantly monitor the temperature in both the upper and lower part of the chamber. The sensors are located in the liquid loaded monitor bottles, which are in the shape of a blood bag to accurately simulate product temperature.

### Insulated windows

Insulated window prevents condensation and ensures temperature uniformity.

### Interior Lamps

Fluorescent interior lamp with ON/OFF switch and a large view window in the outer door provide a clear view of stored items.



**MBR-107D(H)-PA**  
(mm)

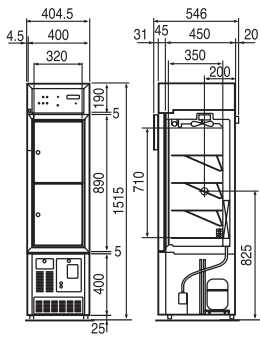

**MBR-304GR-PA**  
(mm)

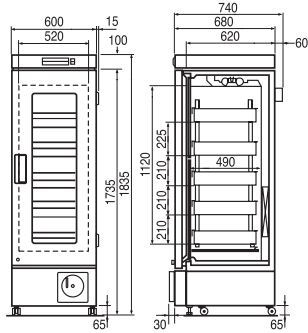

**MBR-705GR-PA**  
(mm)

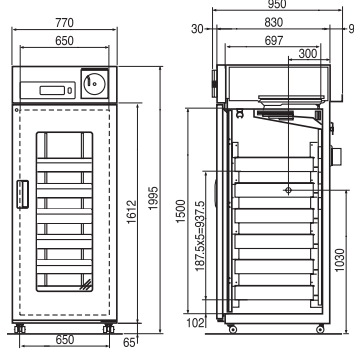

**MBR-1405GR-PA**  
(mm)

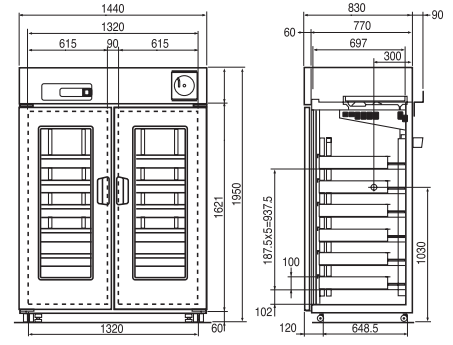

MODEL NUMBER	MBR-107DH-PA	MBR-304GR-PA	MBR-705GR-PA	MBR-1405GR-PA
STORAGE CAPACITY, 450ML BAGS	32	120	360	720
EXTERIOR DIMENSIONS (W X F-B X H)	15.7" x 19.5" x 59.6" 400 x 495 x 1,515mm	23.6" x 26.8" x 72.2" 600 x 680 x 1,835mm	30.3" x 32.7" x 77.0" 770 x 830 x 1,955 mm	56.7" x 32.7" x 76.8" 1,440 x 830 x 1,950mm
INTERIOR DIMENSIONS (W X F-B X H)	12.6" x 13.8" x 28" 320 x 350 x 710mm	20.5" x 19.3" x 45.3" 520 x 490 x 1,150mm	25.6 x 27.4" x 59.1" 650 x 697 x 1,500 mm	52.0" x 27.4" x 59.1" 1,320 x 697 x 1,500mm
NET WEIGHT	154 lbs (70 kg)	308 lbs (140 kg)	462 lbs (210 kg)	638 lbs (290 kg)
EFFECTIVE CAPACITY	2.8 cu. ft. (79 liters)	10.6 cu. ft. (302 liters)	21.8 cu. ft. (617 liters)	45.4 cu. ft. (1,287 liters)
EXTERIOR FINISH	Baked-on acrylic finish galvanized steel	← Painted steel →		
INTERIOR FINISH	Stainless steel	← Painted steel →		
CABINET INSULATION	CFC-free rigid polyurethane, foamed-in place			
OUTER DOOR	Triple layer glass windows	Insulated steel frame with double layer glass windows		
DOOR LOCK	1	1	1	2
INNER DOOR, ACRYLIC	2	2	3	6
DRAWERS	—	5 Stainless Steel Roll-out drawers	6 Stainless Steel Roll-out drawers	12 Stainless Steel Roll-out drawers
SHELVES	3 zinc-plated steel wire and 1 stainless steel	—	—	—
HERMETICALLY SEALED COMPRESSOR	110w	175w	220w	300w
REFRIGERANT	R-134a (HFC)			
AIR TEMPERATURE UNIFORMITY	±1.5°C at 4°C			
AIR CIRCULATION	Forced air circulation			
DEFROST	Fully automatic, microprocessor controlled			
TEMPERATURE CONTROL	Microprocessor control			
TEMPERATURE ALARM	Factory preset at 2°C and 8°C. Fully user adjustable			
POWER FAILURE ALARM	Audible and visual alarm (9 hours), automatic rechargeable battery (Ni-MH)	Audible and visual alarm (24 hours), automatic rechargeable battery (Ni-MH)		
DOOR ALARM	Visual Alarm	Audible and Visual Alarm		
REMOTE ALARM CONTACT	DC30V, 1A, normal open; temperature alarm or power failure alarm	DC30V, 2A, normally open or normally closed; temperature alarm or power failure alarm		
TEMPERATURE MONITOR	—	250ml x 2 product simulation probe bottles with thermistor sensor		
LIGHTING, FLUORESCENT	6w	15w	20w	
ACCESS PORT	1	1	2	
RECORDER	30 days recorder	1/7/30 day circular recorder		
WIRELESS MONITORING	LabAlert Wireless App/Cloud based monitoring system			



# Undercounters Refrigerators & Freezers

Designed for the demanding standards of clinical, life science, pharmaceutical, biotechnology, and industrial laboratories. The Panasonic freestanding or Under the Counter Scientific Grade Laboratory Refrigerators and Freezers feature Panasonic designed compressors and key components, stringent quality control processes. They maintain the highest quality standard laboratory appliances available today.

**Models:** SR-L6111W-PA, SR-L4110W-PA, SR-L4110WSEC-PA  
SF-L6111W-PA, HF-5017W-PA, HF-5017WSEC-PA







## Temperature Setpoint

Comprehensive temperature set point with adjustable range from 1°C to 14°C, pre-set alarm at  $\pm 3^\circ\text{C}$  from temperature setpoint, monitoring based on a sophisticated microprocessor controller with digital display.

## Easy Install

Allows for easy installation undercounter, counter-top, or within the knee-well of laboratory cabinetry. Door shelves and standard shelving maximize product storage capacity. Some models are stackable.

## LED Display

Easy to read, angled LED display and keypad. Digital input of temperature with setpoint range from 1°C to 14°C allows end user temperature flexibility.



SR-L6111W-PA  
(in)

SF-L6111W-PA  
(in)

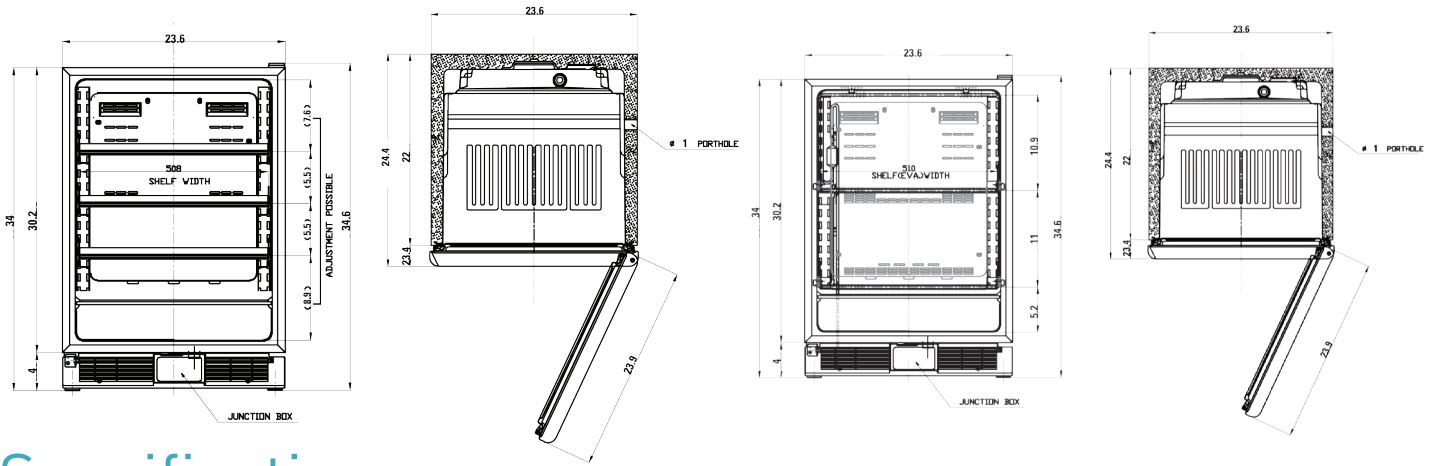

# Specification

MODEL NUMBER	SR-L6111W-PA (REFRIGERATOR)	SF-L6111W-PA (FREEZER)
INTERNAL CAPACITY & VOLUME	6.1 cu.ft. 173 L	5.4 cu.ft. 153 L
EXTERIOR DIMENSIONS (W X F-B X H)	23.6" x 34.6" x 26.2.6"* 600 x 879 x 660 mm	23.6" x 34.6" x 26.2"* 600 x 652 x 876 mm
CLEARANCE REQUIREMENTS	Unit depth with hinge: 34.3", Unit depth with hinge cap: 34.5"	Unit depth with hinge: 34.3", Unit depth with hinge cap: 34.5"
REFRIGERATION SYSTEM	No clearance required from top, back and sides of cabinet	No clearance required from top, back and sides of cabinet
TEMPERATURE CONTROL	Panasonic built compressor, R134A HFC "Green" refrigerant, and zero clearance front-breather condenser design	Evaporator shelf cooling with manual defrost
TEMPERATURE SETPOINT RANGE	Forced air circulation with microprocessor digital input	1°C to 14°C
ALARM RANGE	Tracking alarm ±3°C around setpoint, remote alarm contacts	-15° to -20°C
ACCESS PORT	13/16" (30mm) hole diameter	
INTERIOR STORAGE	3 adjustable wire shelves	2 Fixed evaporator shelves
DOOR SWING	Right hand hinged door swing	
SECURITY FEATURES	Keypad lockout feature, keyed door lock, optional padlock hasp (not included)	
ELECTRICAL REQUIREMENTS	115V, 60Hz, NEMA 5-15 Receptacle	
WEIGHT	110 lbs. 50 kg	110 lbs. 50 kg



# LabAlert™

## Monitoring System

Complete your refrigeration requirements with Panasonic LabAlert™ monitoring solution.

LabAlert™ makes the monitoring of your refrigerators and freezers easier than ever. You can keep a constant check on the temperature, door status, pressure, and even refrigerant leaks in real time – anytime, anywhere. Easy set up, affordable pricing, infinite scalability and intuitive user interface.

### For iPhone, iPad & Android devices

Access your LabAlert™ account from anywhere, at any time. All you need is a computer, smartphone, or tablet device.

### For Web

The web and app-based interfaces let you set up customizable dashboards to centrally monitor your equipment in a single view.

## SIMPLE SETUP

### STEP 1 - Unit

- Install Sensor to Refrigerator
- Plug in Probe to Sensor

### STEP 2 - Receiver

- Open Refrigerator Access Port
- Place Probe into Freezer

### STEP 3 - Cloud

- Position Probe in Chamber
- Activate Sensor

### STEP 4 - You

- Sensor Communicates with Gate
- Customer Monitors Data on LabAlert™







### SIMPLICITY

Easy setup, affordable pricing, infinite scalability, and an intuitive user interface. LabAlert™ makes advanced laboratory monitoring more accessible than ever!



### CONVENIENCE

Now checking on your lab is as easy as checking your email. All you need is a smartphone, tablet, or computer to access critical data from any location.



### SECURITY

LabAlert™ is always on watch. Receive instant alerts pushed directly to your cell phone the instant anything goes wrong. Easily customizable alert triggers are also available to help you meet the demands of your lab.

FEATURE	ADVANTAGE	LABALERT™	COMPETITORS
COST	✓	Economical and versatile choice - Cost decreases with the increase in units	Not economical with larger number of units
COMPATIBILITY	✓	Compatibility with multiple systems	Not compatible to other units
COMPLIANCE	✓	21 CFR Part 11 Compliance, NAFEM data protocol, TJC standard and HACCP	Most of them are 21 CFR Part 11 compliant
HOSTING	✓	Web, App, Cloud, Standalone Software	Only web or local
RANGE	✓	WiFi - 2.4 GHz	Wired or Wireless
SCALABILITY	✓	Ability to expand infinitely for multiple units	Do not have such flexible capabilities
MAINTENANCE	✓	Preventative maintenance reminders and reports with service alerts	Simple summary of real time data + Historical chart data



# Professional Service and Support

We provide full product service support to maintain Panasonic standards of product safety, reliability and high performance. The combination of our multi-national network of factory-trained service professionals, detailed documentation of field performance, and high-value on the customer feedback helps us to deliver best-in-class, end-user support for our customers.

## Convenience of Panasonic Product Service

- Panasonic service specialists are trained to:
  - Perform remote and on-site diagnostics
  - Repair and replace worn components
  - Offer preventative maintenance programs as per your needs and budget
- Many Panasonic Healthcare products include self-diagnostics that permit authorized service technicians to determine how and when service calls are required.
- We offer training to selected facility biomedical engineers and service staff for authorized in warranty and post-warranty repairs.
- Because our products are sold and serviced worldwide, products acquired in one country under grant or facility-sharing programs are easily supported if moved to facilities in the next city or around the world.



# Validation Services

Panasonic offers a wide range of high-quality services for all our equipment. These services include on-site validation, customer validation support packages, factory acceptance testing and NIST calibration.

Choosing Panasonic as an equipment supplier and validation consultant can greatly reduce the time and cost involved with getting new equipment compliant and ready for use.

## Unique Services Panasonic Offers:

- On-site consultation
- Unit specific authorized protocol documents
- Customizable testing procedures to meet customer specific requirements
- Free archiving of unexecuted testing protocols
- Unbiased testing of competitive equipment

## Pre-delivery Services:

- Validation support
- Consultation
- Factory Acceptance Testing
- Calibration
- Temperature mapping

## On-site Services:

- Installation qualification
- Operational qualification
- Performance qualification
- Calibration
- Temperature mapping





## Panasonic<sup>®</sup>

Panasonic Healthcare Corporation of North America  
1300 Michael Drive, Suite A, Wood Dale, IL 60191  
Toll Free USA (800) 858-8442, Fax (630) 238-0074  
[us.panasonic-healthcare.com](http://us.panasonic-healthcare.com)

© Panasonic Printed in USA | 05/2014 AG