

Chart Industries

Liquid Discharge Device

Installation and Operating

Instructions

Part Numbers

10668004 Lab-30

10668021 Lab-50

10668101 Lab 10 2-1/8"

13467208 Lab-10 EXT RBR

13464867 Lab-20 EXT RBR

13484139 Lab-20 2-1/8"

21293002 YDS-10L EXT RBR

21293003 YDS-20L EXT RBR

21293004 YDS-30L EXT RBR

21293005 YDS-40L EXT RBR



GENERAL:

The MVE liquid discharge device provides liquid nitrogen for filling cold traps and smaller dewars without having to scoop out or pour liquid nitrogen from the vessel. The liquid discharge device utilizes the normal evaporation of the cryogenic liquid to pressurize a container by plugging the neck of the vessel and forming a hermetic seal. The pressurized vessel can then decant product through the liquid discharge device. Figure 1 shows a drawing of the liquid discharge device. The primary components of the liquid discharge device are listed below:

- **Rubber Stopper:** Provides a seal against the walls of the neck tube. Tightening the wing nut expands the rubber stopper.
- **Pressure Gauge:** Indicates the pressure inside the container.
- **Relief Valves:** Relieves pressure inside the container automatically when excessive pressure is reached. The relief valves are safety devices and cannot be adjusted.
- **Vent Valve:** Provides means to vent product. The vent valve can be closed to pressurize the vessel or opened to depressurize the vessel.
- **Discharge Valve:** Allows product to flow out of the vessel through the discharge device spout.
- **Safety Cable:** Prevents discharge device from accidentally exiting completely from vessel.

INSTALLATION:

Perform the following steps to install the liquid discharge device on a vessel:

- 1) Attach the discharge device spout to the liquid discharge device (refer to Figure 1 for location). A transfer line can be used in place of the discharge device spout. The transfer line can be ordered from MVE (P/N 9713159) along with the required adapter fitting (P/N 1110052).
- 2) Verify that the rubber stopper is dry and free from grease and other contaminants. Check for nicks and gouges that may impair normal operation.
- 3) Verify that the cable is in good working condition.
- 4) Verify that the vent and discharge valves turn freely.
- 5) Loosen wing nut.
- 6) Lower discharge device into vessel. As the discharge device is lowered, the nitrogen in the vessel will boil until the dip tube has cooled down. The boiling action is normal. Continue lowering until the rubber stopper fits snugly.
- 7) Clip the safety cable to the vessel handle.
- 8) Tighten the wing nut until it contacts the washer. Tighten wing nut another 1-1/2 to 2 turns (EXT RBR versions 4-5 turns).
CAUTION: Tighten the wing nut with hands only, do not use any tools. Tightening the wing nut expands the rubber stopper against the neck tube of the vessel. Excessive tightening may damage the neck tube.
- 9) Close the vent valve and the discharge valve. Pressure will slowly begin to build. Several hours will be required to achieve sufficient pressure to operate the liquid discharge device. Pressure buildup can be accelerated by gently tipping the vessel at 45° angle.
CAUTION: Excessive pressure can rupture the vessel.

OPERATION:

Perform the following steps to withdraw liquid from the vessel with the liquid discharge device:

- 1) Turn the discharge valve fully open and then turn back the valve a half turn. Do not leave the valve in the fully open position.
- 2) Close the discharge valve to end liquid withdrawal.

WARNING: Cryogenic liquids are extremely cold and can cause severe burns similar to frostbite. See CGA Bulletin No. P-12 Safe Handling of Cryogenic Liquids. (This bulletin may be ordered

from: Compressed Gas Ass'n., 4221 Walney Road, 5th Floor, Chantilly, VA 20151.)

WARNING: Nitrogen vapors in air may dilute the concentration of oxygen necessary to support or sustain life. Exposure to such oxygen deficient atmosphere can lead to unconsciousness and serious injury, including death.

WARNING: Modifying safety valves on discharge devices causes potentially hazardous conditions.

REMOVAL OF LIQUID DISCHARGE DEVICE:

Perform the following steps to remove the liquid discharge device from the vessel:

- 1) Open the vent valve to remove all pressure.
WARNINGS: Vessel must be completely vented before removing the discharge device. Any attempt to remove the discharge device before the vessel is completely vented may result in serious personal injury.
- 2) Verify that the pressure gauge reads 0.
- 3) Release wing nut.
- 4) Rock discharge device from side to side to free stopper.

- 5) Pull discharge device from vessel.
- 6) When stopper has passed rim of vessel, unclip safety cable.
- 7) Store liquid discharge device in a clean and dry area.
- 8) Cover vessel.

REPLACEMENT PARTS:

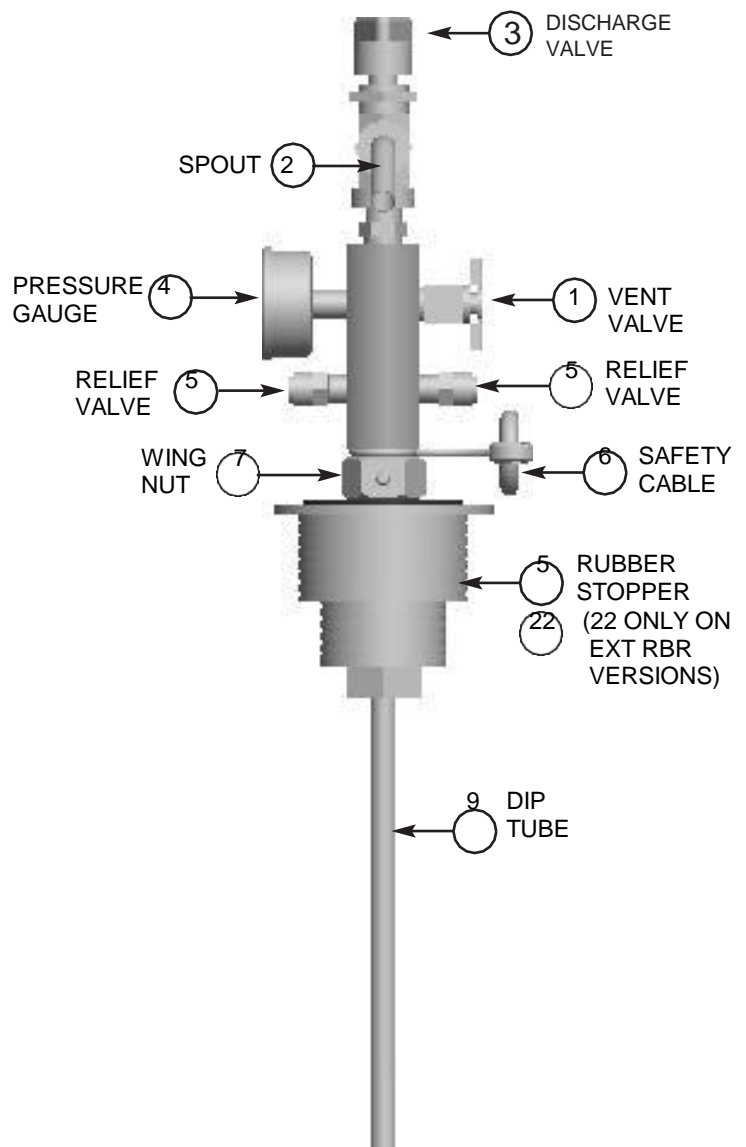

NOTE: If phase separator is required on spout use P/N 11734421.

REPLACEMENT PARTS CON'T:

The following is a list of replacement parts that are common to all discharge devices.

Item Number	Part Number	Description
1	1711042	Vent Valve, 1/4" NPT
2	5612941	Spout, 3'8" O.D.T.
3	10664126	Discharge Valve, 1/4" NPT
4	2010024	Pressure Gauge, 1'8" NPT, 0 - 15 PSIG
5	14235804	Relief Valve, 1/8" NPT, 5 PSIG
6	9027109	Safety Cable
7	2912001	Wing Nut
Not Shown	3810209	Label, Caution

The following is a list of components which must be ordered for a specific discharge device.

Discharge Device Part Number	Rubber Stopper Part Number	Dip Tube Part Number
10668004	47-1014-7	90-2712-1
10668021	47-1014-7	90-2715-1
10668101	47-1080-7	90-2719-1
13467208	47-1006-7 & 13465974	90-2719-1
13464867	47-1006-7 & 13465974	90-2709-1
13484139	47-1080-7	90-2709-1
21293002	47-1006-7 & 13465974	21293006
21293003	47-1006-7 & 13465974	21293007
21293004	47-1006-7 & 13465974	21293008
21293005	47-1006-7 & 13465974	21293009

Chart Inc.
1300 Airport Drive
Ball Ground, GA 30107
Ph 770-721-7700 • Toll Free 1-800-482-2473
Fax 770-721-7701



Innovation. Experience. Performance.

www.chartbiomed.com

Chart BioMedical, Ltd.
Unit 6 - Ashville Way
Wokingham RG412PL
United Kingdom
Ph +44(0) 1344 403100
Fx +44(0) 1344 429224

Copyright © 2018 Chart
Industries. Ref. 11047331
Rev. K