

# Product datasheet

## CaptairStore 822B

Ductless filtering chemical storage cabinet

### Safer to operate

- Exclusive Erlab filtration technology
- Filtration performances tested in accordance with AFNOR NF X 15 211
- Secured storage
- Filtration failure sensors for solvents, acids or formaldehyde
- Erlab Safety Program: be guided for the right choice of your secured storage solutions
- Connect with eGuard™ for real-time status, notifications and alerts

### Simpler to use

With Smart Technology (optional), you can easily see that the cabinet is operating safely.

Should the light pulse, you are notified that:

- Containment has been compromised or,
- The filter has breakthrough or,
- There is a fan failure

### Flexibility

- Two models are available:
  - 2 storage compartments with sliding doors
  - 1 drawer and sliding shelf
- Easy and fast relocation

### Savings

- No ductwork needed
- Low annual energy cost
- Low replacement filter cost

### Environment

- Pollutants filtered at the source



You get the highest level of filtration performance.



Powerful light guided communication



Connect your equipment and benefit from the remote access thanks to our mobile solutions\*



Download our eGuard application



**Option 1: Storage cabinet with 2 compartment and sliding doors**

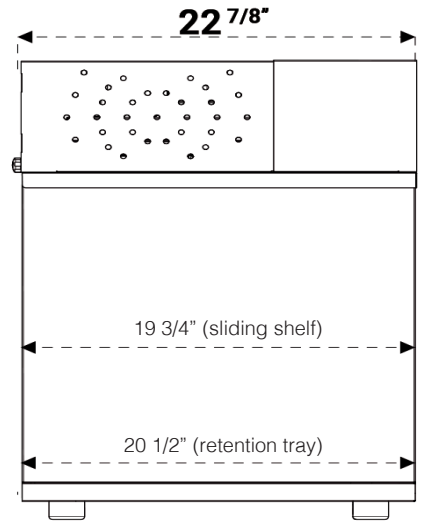
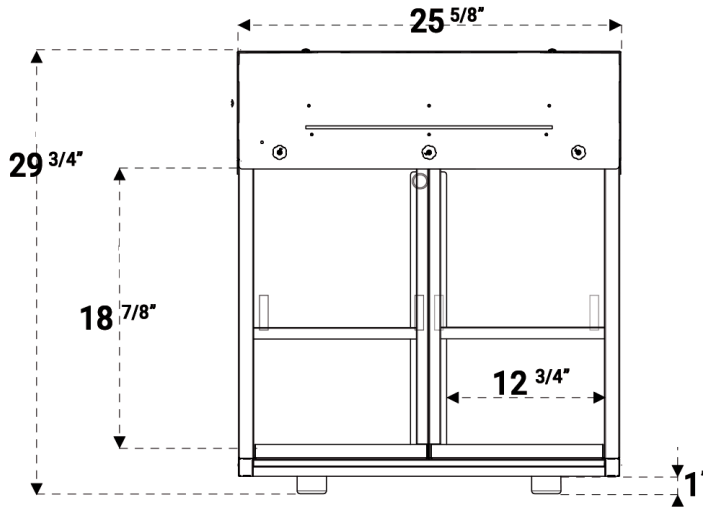

**Option 2: Storage cabinet with 1 drawer and 1 sliding shelf**

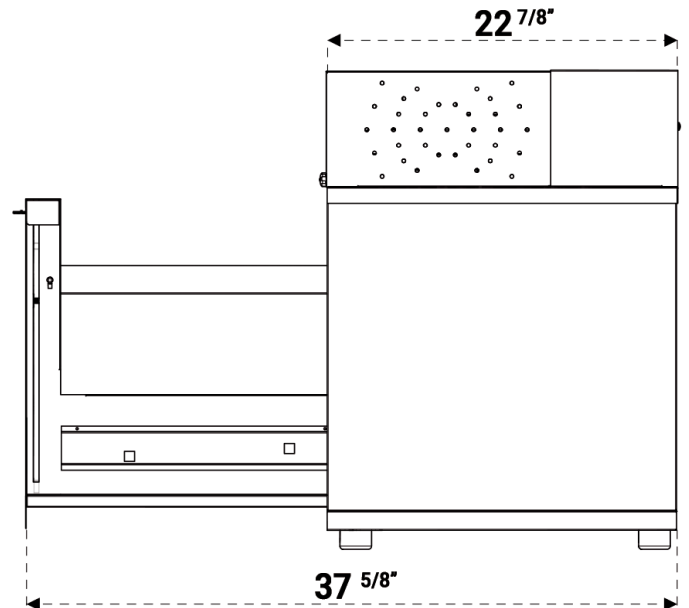
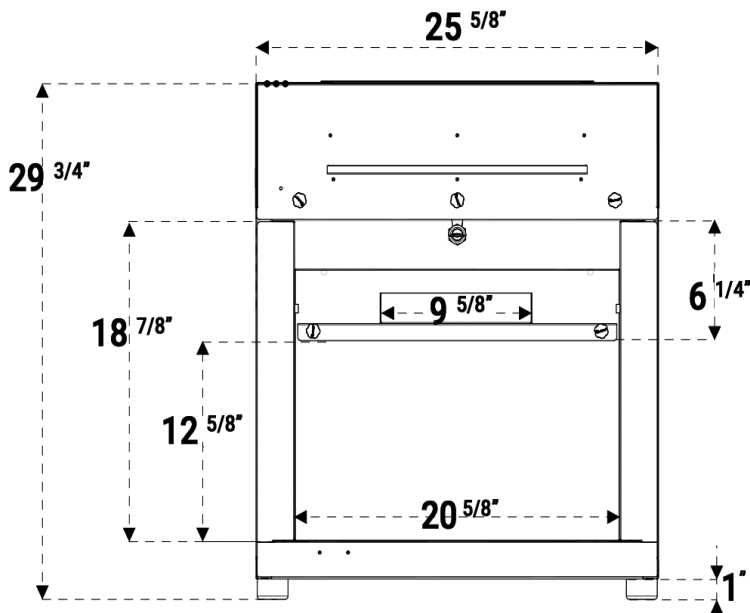

## Technical specifications

<b>Safety Standards</b>	Filtration performances tested according to the AFNOR NF X 15-211:2009 standard : France EN 1822 : 1998 (HEPA H14 Filters) - CE Marking
<b>Air Flow</b>	70 m3/h / 41 CFM
<b>Voltage/Frequency</b>	90 - 220 V / 50-60 Hz
<b>Power consumption</b>	35W
<b>Structure</b>	Corrosion resistant electro-galvanized steel coated with anti-acid polymer
<b>Doors</b>	Clear, chemical resistant acrylic for easy viewing
<b>Filtration Module</b>	Polypropylene

## Features

<b>Smart Technology (optional)*</b>	When the light is pulsing: -Door(s) left open -Containment is compromised -Filter breakthrough
<b>Carbon filtration</b>	AS : For organic vapors - BE : acid vapors F : For formaldehyde vapors - K : For ammonia vapors
<b>Particulate filtration for powders</b>	HEPA H14:99.995 % efficiency filtration of particles over 0.1 µm in size
<b>eGuard app* (Android or iOS)</b>	For remote control to monitor the status of the storage cabinet, change the settings, and deliver safety alerts immediately to your devices (mobile, tablet and PC)
<b>Doors sensors*</b>	Alarm if doors are left open
<b>Chemical Listing</b>	List of approved chemicals

## Storage configurations

	Option 1	Option 2
<b>Storage capacities</b>	50 x 1L bottles	25 x 1L bottles (retention tray) 50 x bottles (drawer)
<b>Storage compartments</b>	2	1
<b>Delivered with</b>	2 trays + 2 sliding Shelves	1 drawer + 1 sliding shelf
<b>Retention trays</b>	2	1
<b>Lock</b>	Key lock	

## Options

<b>Molecode*</b>	Detection sensor: Type S, for solvents / Type A, for acids / Type F, for formaldehyde
------------------	---

\* Not available on Captair 822B Midcap



Erlab's state of the art Research & Development Laboratory relies exclusively on filtration

# About Erlab

## We provide safety, we protect your health

Erlab invented the ductless fume hood in 1968. With more than 50 years of experience in the field of chemical filtration and protection of laboratory personnel; we know the formula for safety. With Erlab, you will never have to wonder or worry if our products are safe. We build each one of the following 7 ingredients into our products, and without all of them, your health and safety will be compromised.

### 1 Erlab R&D Laboratory

The engineers and chemists in our state-of-the-art R&D laboratory understand molecular filtration. We are committed to designing products that are safe and of the highest quality, strive to improve our products, and continuously develop new products that provide greater protection in the laboratory.

### 2 Strict Safety Standards

We hold ourselves to the highest standard and adhere to the strict AFNOR NF X 15-211: 2009 filtration safety standard as cited by ANSI Z9.5-2012.

### 3 A Published Chemical Listing

It all begins here. Without this listing, we are not compliant with AFNOR NF X 15-211. Our in-house laboratory tests, as well as independent testing, to verify the retention capacity of over 700 chemicals for our filters.

### 4 Independent Testing

Erlab filters have been independently tested multiple times at various concentrations guaranteeing that our safety solutions all adhere to the strict performance criteria of the AFNOR NF X 15-211:2009 standard assuring that the emission concentration at the filter exhaust will always be lower than 1% of the TLV.

### 5 Application Questionnaire (Valiquest)

Our laboratory specialists will recommend the appropriate filtration fume hood, type of filter, and personalized advice.

### 6 Certificate of Validation for the chemicals used in the hood

A certified PhD chemist issues a Certificate of Validation with a list of the chemicals approved for use in the hood.

### 7 Our Safety Program

We back up our products 100%. This program includes your specialized chemical evaluation, validation of your hood upon installation, and a filtration safety specialist at your service to ensure that your hood is operating to its full potential.

Copyright © Erlab France - Technical data are not contractual. Erlab reserves the right to modify the present document without prior notice.

France  
+33 (0) 2 32 09 55 80 | ventes@erlab.net

United States  
+1 800-964-4434 | sales@erlab.com

China  
+86 (0) 512 5781 4085 | sales.china@erlab.com.cn

Spain  
+34 936 732 474 | export.south@erlab.net

Germany  
0800 330 47 31 | export.north@erlab.net

United Kingdom  
+44 (0) 1722 341 940 | export.north@erlab.net

Italy  
+39 (0) 2 89 00 771 | export.south@erlab.net

 [usa.erlab.com](http://usa.erlab.com)