

Operating manual

UVP PCR Workstations



Manufacturer Analytik Jena US
2066 W. 11th Street
Upland, CA 91786
USA
Phone +1 (909) 946 3197
Fax + 1 (909) 946 3597
Email info@us.analytik-jena.com

Service (except United States) Analytik Jena AG
Konrad-Zuse-Str. 1
07745 Jena · Germany
Phone + 49 3641 77 7407
Fax +49 3641 77 7449
Email service@analytik-jena.de

Service (United States) Analytik Jena US
2066 W. 11th Street
Upland, CA 91786
USA
Phone +1 (909) 946 3197
Fax + 1 (909) 946 3597
Email info@us.analytik-jena.com

General Information Analytik Jena US: www.us.analytik-jena.com
Analytik Jena AG: www.analytik-jena.com

Documentation number 81-1274-01

Version Rev. C (March 2019)

Implementation of the Analytik Jena US
Technical Documentation

Contents

1	Introduction	5
2	Safety Information	6
3	Specification	7
4	Operational Ratings	8
5	System Assembly	9
6	System Use	20
6.1	Workstation Interface	20
6.2	UV Decontamination	21
7	Cleaning	22
8	Maintenance and Care	23
8.1	UV Bulb Replacement	24
8.2	Filter Replacement (HEPA models only)	25
8.2.1	Pre-filter Replacement	25
8.2.2	HEPA filter replacement	26
8.3	Replacement Parts	27

1 Introduction

The HEPA and non-HEPA PCR Workstations create an ideal environment for preparing PCR samples by reducing the chance of contamination. The built-in high intensity shortwave (254nm) UV provides a source for inactivation of DNA between experiments. Additional contamination control is provided by the specially-coated stainless steel and aluminum design that maintains antimicrobial efficacy. The surface resists growth of destructive bacteria, molds and fungi. The Makrolon panel assembly blocks UV below 400nm.

The UV/Air recirculator, included as standard on all PCR Hoods, eliminates DNA amplicons or genomic DNA from a previously-dispensed experiment.

2 Safety Information

The PCR Hoods are designed with functionality, reliability and safety in mind.

The workstations provide shortwave (254 nm) UV which is a powerful source of UV radiation that will cause damage to unprotected eyes and skin. Before operating, ensure that all personnel are properly protected and that the instructions for the use of this equipment are followed. A safety shut-off switch automatically turns off the UV light when the door is open, protecting users from UV exposure. In addition, the Makrolon panels are specially formulated to block UV wavelengths below 400 nm.

Disconnect the power supply before assembling or servicing the PCR Workstation.

The PCR Workstation weighs over 100 lbs. (45 kg). It is recommended two or more people lift, move and/or handle the workstation to prevent injury and/or damage to the unit.

3 Specification

Feature	UVP PCR Workstation	UVP PCR HEPA Workstation
UV Source (254nm)	In 2 separate chambers: <ul style="list-style-type: none"> ▪ Inside the workstation (25W x 2) ▪ Air recirculator at the bottom (dual UVC light tubes) 	In 3 separate chambers: <ul style="list-style-type: none"> ▪ Pre-filter chamber (dual UVC light tubes) ▪ Inside the workstation (25W x 2) ▪ Air recirculator at the bottom (dual UVC light tubes)
UV Safety	UV shut-off switches in all the chambers Red LED ambient light to indicate UV on	
White light	Overhead white LED lights brightly illuminates the work area	
Filter module	No filter	2-stage filter module: Carbon pre-filter HEPA filter
Timer	15 minutes, 30 minutes, custom (up to 99 minutes)	
Power outlets	2	
Shelves	2	
Work surface	Antimicrobial coated stainless steel and aluminum	
External Dimensions (H x W x D)	39 x 32.5 x 24.25 (inch.)	39 x 32.5 x 24.25 (inch.)
Internal Dimensions (H x W x D)	29 x 31 x 21.5 (inch.)	29 x 31 x 21.5 (inch.)
Weight	115 lbs.	130 lbs.
UV Intensity*	570 μ W/cm ²	570 μ W/cm ²
Re-circulator Air Flow*	560 ft/min	560 ft/min
HEPA Air Flow*	N/A	Low: 4 ft/min Medium: 53 ft/min High: 110 ft/min

*Measures are average values taken over a long period of time. Individual performance may vary.

4 Operational Ratings

- PCR workstations are intended to be used indoors only.
- Altitude must not exceed 2,000m.
- Ambient temperature must not exceed 5°C to 40°C (41°F to 104°F).
- Relative humidity must not exceed 80% for temperatures up to 31°C (88°F) decreasing linearly to 50% relative humidity at 40°C (104°F).
- Main power supply voltage fluctuations must not exceed $\pm 10\%$ of the nominal voltage.
- Pollution rating 2 or better for laboratory areas.

Part Number	Description	Voltage
849-95-0600-01	UVP HEPA PCR Workstation	115V
849-95-0600-02	UVP HEPA PCR Workstation, EURO Plug	230V
849-95-0600-03	UVP HEPA PCR Workstation, UK Plug	230V
849-95-0601-01	UVP PCR Workstation	115V
849-95-0601-02	UVP PCR Workstation, EURO Plug	230V
849-95-0601-03	UVP PCR Workstation, UK Plug	230V

5 System Assembly



CAUTION

Risk of injury! The PCR Workstation weighs over 100 lbs. (45 kg).

- Use two or more people to lift, move and handle the unit. Use proper lifting technique to prevent injury.
-



Assembled UVP PCR HEPA Workstation

1. Prior to assembly, verify all components are present. Use the packing list provided below to verify all parts have been received:

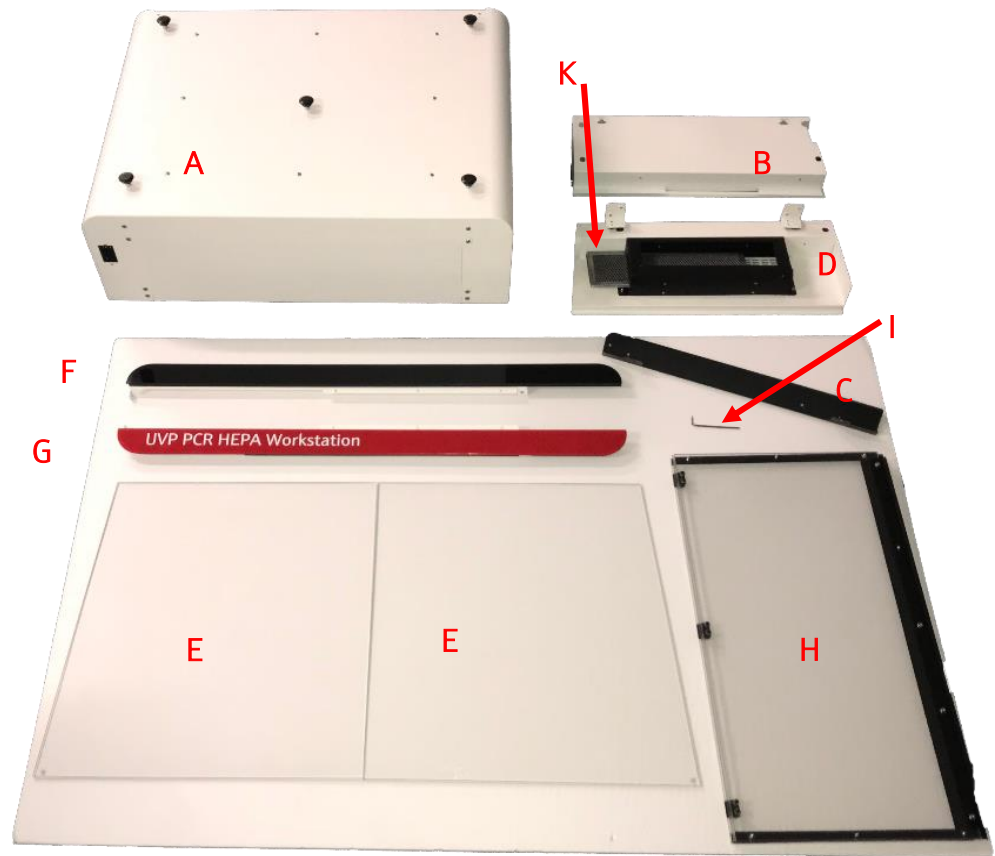

Unpacked Workstation

Part	Name	Quantity
A	PCR Workstation body	1
B	White Makrolon Panel Holder	1 (2x for non-HEPA)
C	Black Makrolon Panel Holder	1 (HEPA only)
D	Pre-filter door	1 (HEPA only)
E	Makrolon Panels	2
F	Black Strut	1
G	Red Strut with product name	1
H	Removable Front Makrolon Panel Assembly	1
I	Allen Wrench	1
K	Carbon Prefilter	1

2. Unfold the workstation.

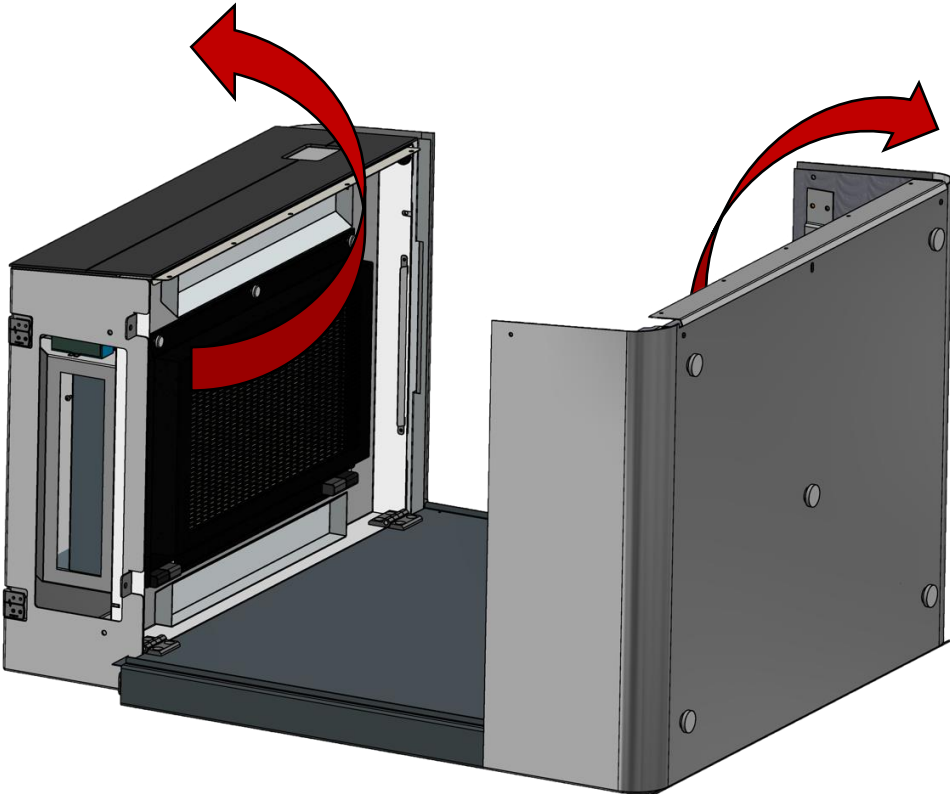

3. Attach part B (White Makrolon Panel Holder).

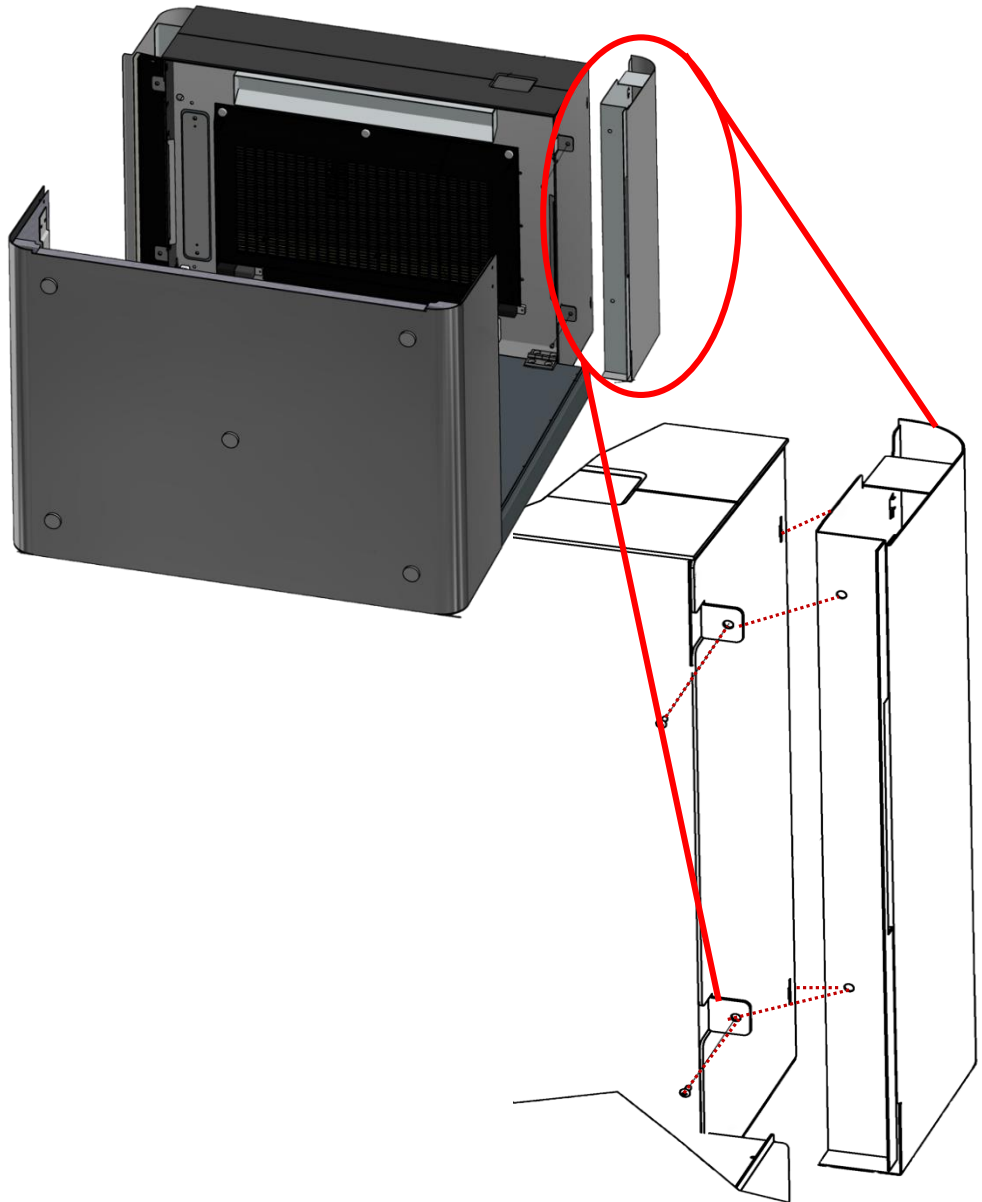
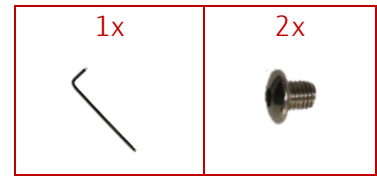

Non-HEPA Units: Non-HEPA units receive 2 parts B. Fit it the second B part on the opposite of the unit as shown above.

4. HEPA units: Attach part C (Black Makrolon Panel Holder).

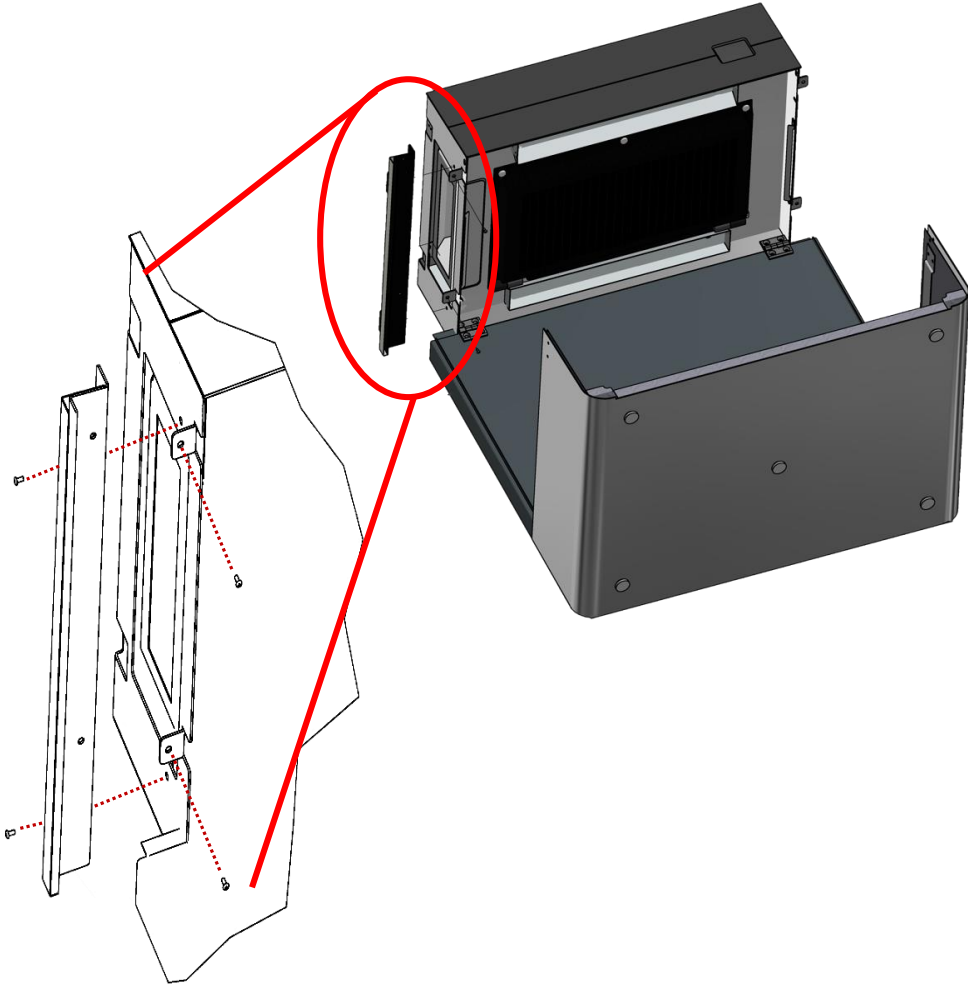
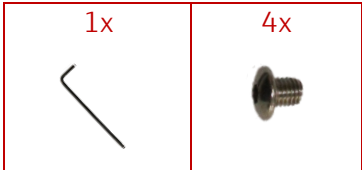

5. HEPA units: Attach part D (Pre-filter door).

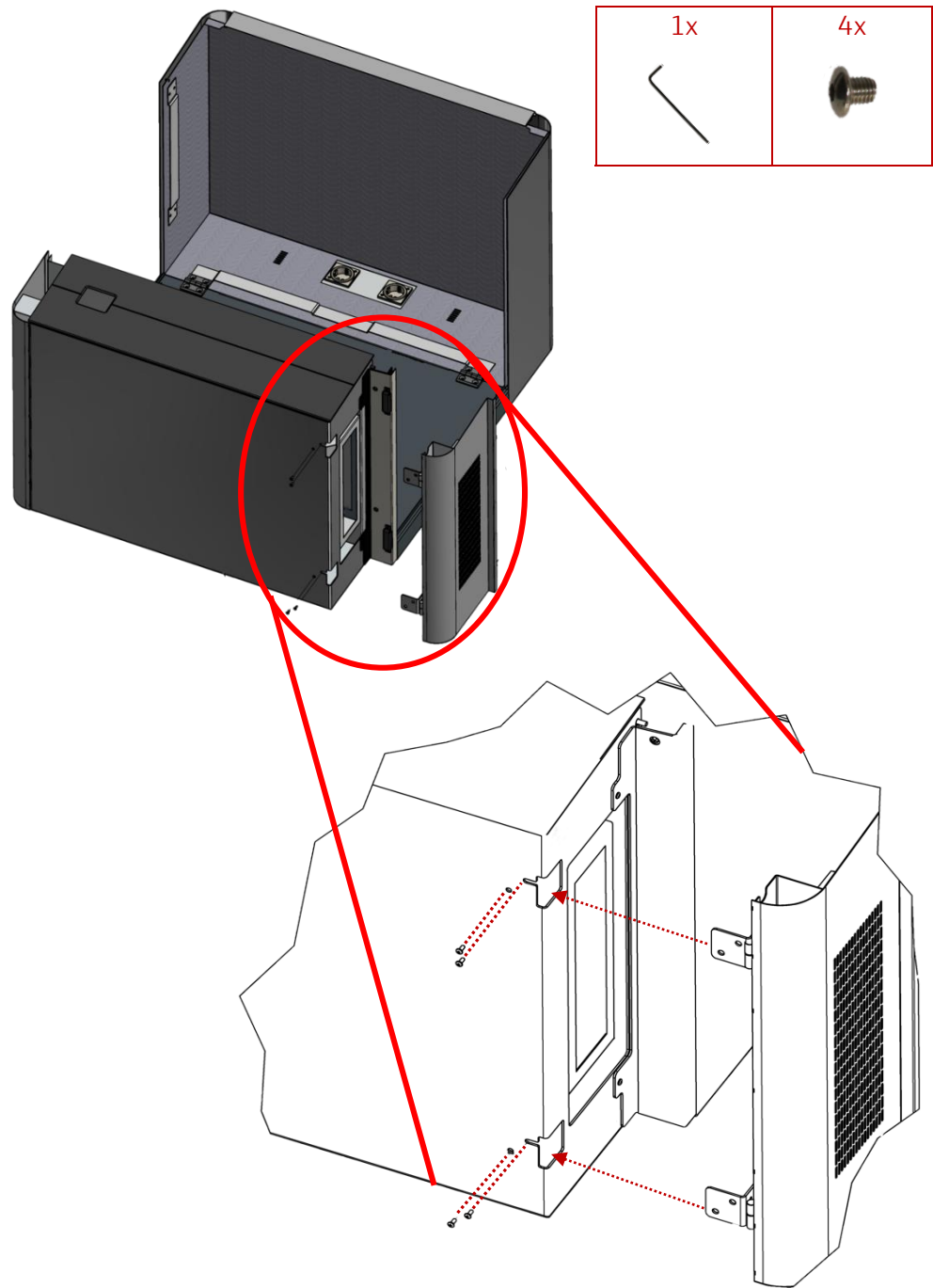

6. Slide in part E (Makrolon panels).

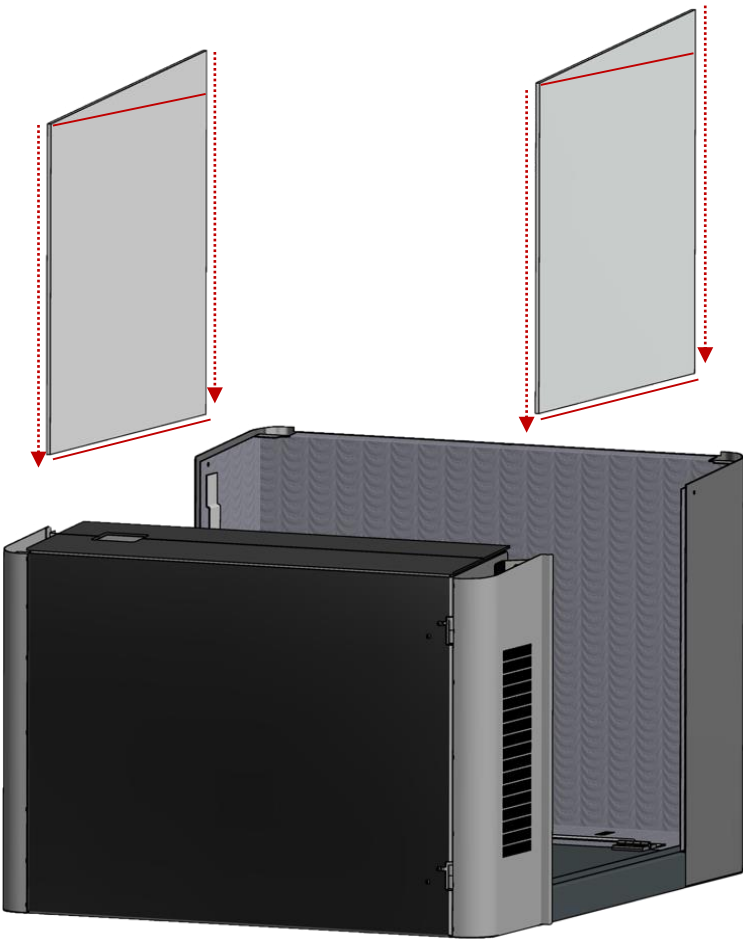

8. Attach part G (Red Strut with product name).

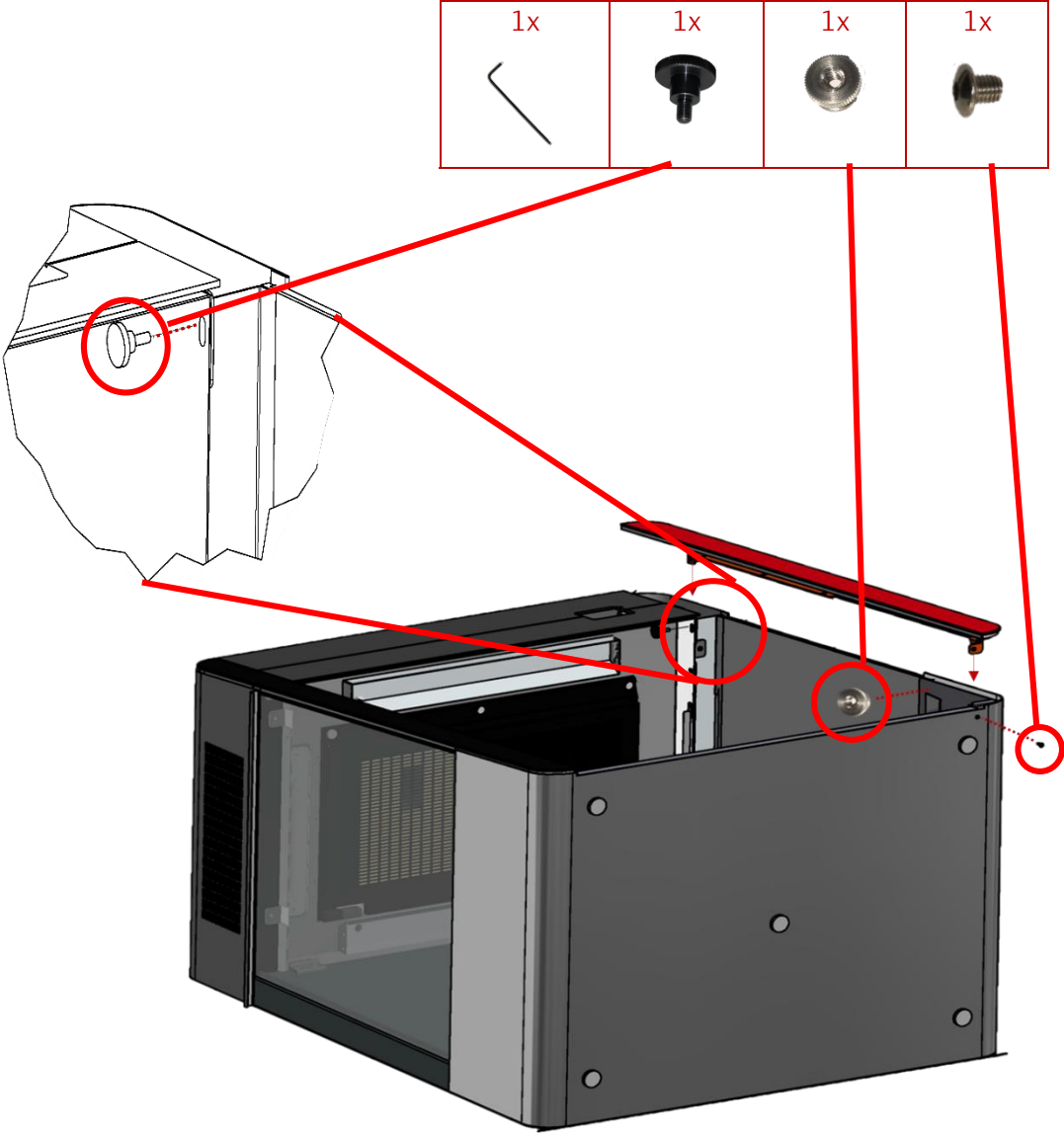

9. Attach part H (Removable Front Makrolon Panel Assembly).

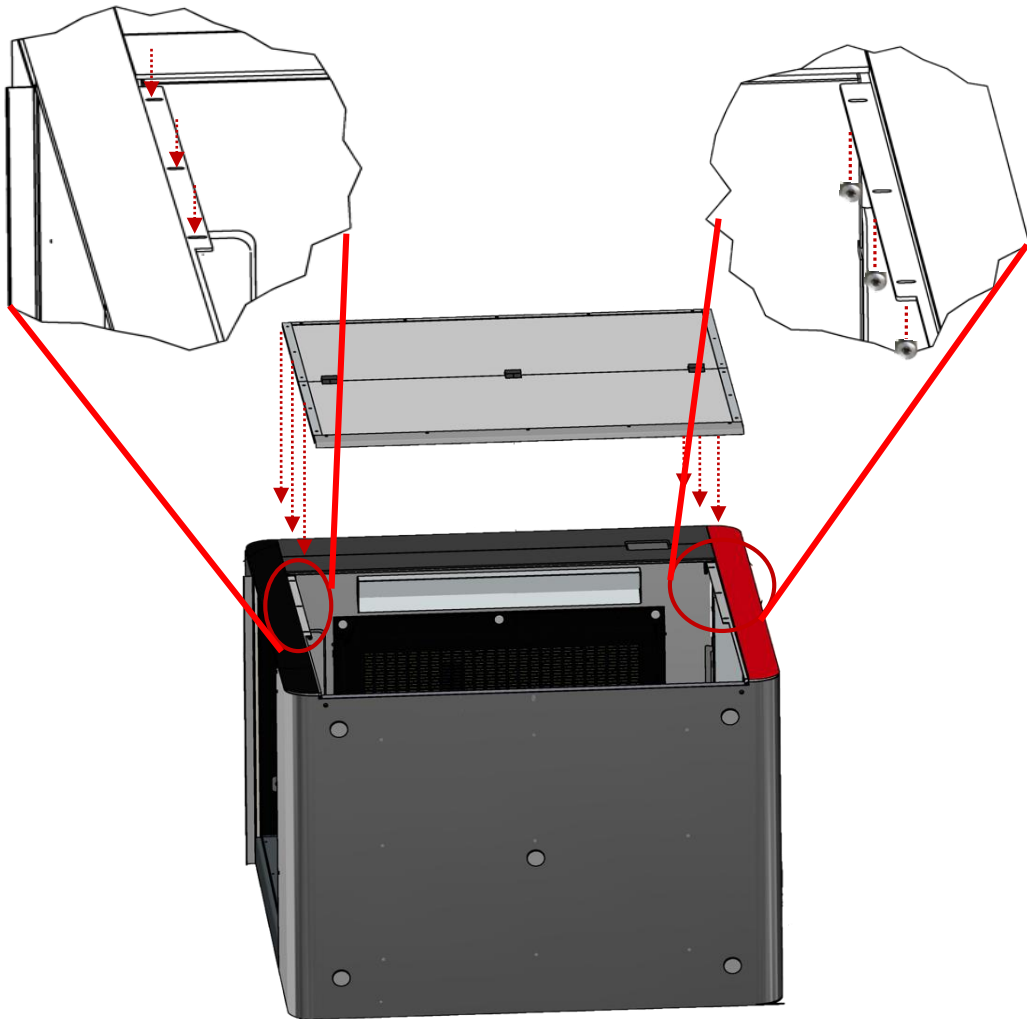

10. Verify front door assembly and seal.

- Open the doors upward. Verify, that the magnets attach at the top front and hold the door in the upright position.
- Verify the door magnetically seals at the bottom of the unit. An audible click should be heard when separating the door from the magnetic bottom.
- If the door does not align and close perfectly, it may be due to how the unit sits on the lab bench. Should this happen, unscrew the 6 thumbnuts securing the door, readjust the door so it aligns perfectly, then reapply the thumbnuts.
- HEPA unit: Install the carbon pre-filter inside the carbon pre-filter door (see also section "HEPA filter replacement" p. 26).

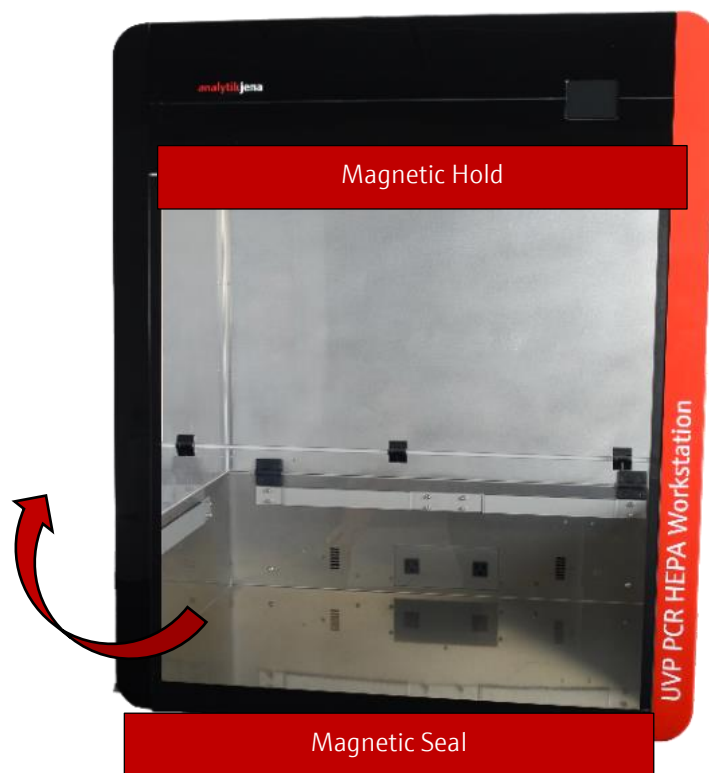

6 System Use

The HEPA and non-HEPA models of the PCR Workstation features touchscreen controls for all major functions of the unit.

6.1 Workstation Interface



White Light

Toggles white LEDs on/off



Overhead Fan with 4 settings:

- Low: 1 tap
- Medium: 2 taps
- High: 3 taps
- Off: 4 taps



Recirculation Fan

Toggles recirculation fan on/off.



UV Decontamination

Provides access to UV decontamination settings.



Settings

Provides access to system settings.

6.2 UV Decontamination

The PCR workstation includes both built-in decontamination protocols and the ability to create custom protocols. The GUI imaged below shows the options available for UV decontamination.

- Tap on  for opening the UV Decontamination menu.
- Use the buttons [15] and [30] to start the built-in decontamination protocols.



UV Decontamination menu

- For customized protocols tap on  and set the **CUSTOM UV** parameters. Then return to the **UV DECONTAMINATION** menu and start the protocol tapping on [Custom].



7 Cleaning



WARNING

Danger of electrical shock!

Unplug the unit from the main socket before cleaning.

The units are built to provide trouble-free operation.

The door and side panels are made of Makrolon and are subject to scuffing and scratches if improperly cleaned. If crazing of the Makrolon panel occurs, the panel can be replaced. Refer to section "Replacement Parts" on page 27 for part numbers.

The stainless steel and aluminum surfaces are manufactured with an antimicrobial coating to reduce bacterial growth. Care in cleaning and use of the equipment is recommended to reduce erosion of the coating. To clean the unit:

- Wipe excess water from inside the unit and outside the unit with an absorbent soft cloth or sponge.
- Use mild soap and a damp soft cloth or damp sponge to clean the exterior of the unit.
- Use a mild detergent on the interior surfaces.
- Clean the door with a mild detergent; **never** use organic based compounds, Alcohol, or Ammonia containing cleaners.
- Do not use abrasive pads or cleansers.
- A plastic cleaner solution is recommended to clean the door and is available from local plastic supply distributors.

8 Maintenance and Care



WARNING

Danger of electrical shock!

Unplug the unit from the main socket before replacing any part of the unit or servicing the unit.

The UVP PCR Workstations have been designed for simple maintenance without the use of tools. The following section will outline how to perform the required maintenance of the workstation.

The table below summarizes the lifespan of the replaceable parts of the PCR workstation. It is advised to keep track of when different parts have been changed to ensure the system is properly maintained.

Part Number	Description	Recommended Replacement
34-0073-01	UV lamp 254 nm, 25W (2x)	900 hours
17-0151-01	HEPA Filter	1040 hours (or six months)
17-0152-01	Carbon Pre-filter	1040 hours (or six months)
849-98-0125-01	Makrolon replacement kit	As needed

The PCR workstation system firmware will keep track of system usage statistics. The system will alert you when a maintenance item is due. The screenshots below illustrate how the system presents maintenance items.



Home screen indicates replacement needed.



Tapping the alert brings up the maintenance screen.



After replacement, tap the replace buttons, then tap CONFIRM.



✓ The alert is cleared, and system statistics are reset.

8.1 UV Bulb Replacement



Notice

Risk of breaking glass!

Use care when handling UV bulbs as they may break and/or shatter if dropped or handled incorrectly.

All models of the PCR workstation contain UV bulbs used for UV decontamination of the workstation. Following the procedure below to properly replace the bulbs:

1. Switch off the unit and unplug the unit from the main socket.
2. Remove the front door of the workstation, this is to allow easier access the ceiling of the workstation.
To remove the front door of the workstation, unscrew the six thumbnuts located on either side of the front Makrolon panel assembly as shown below.

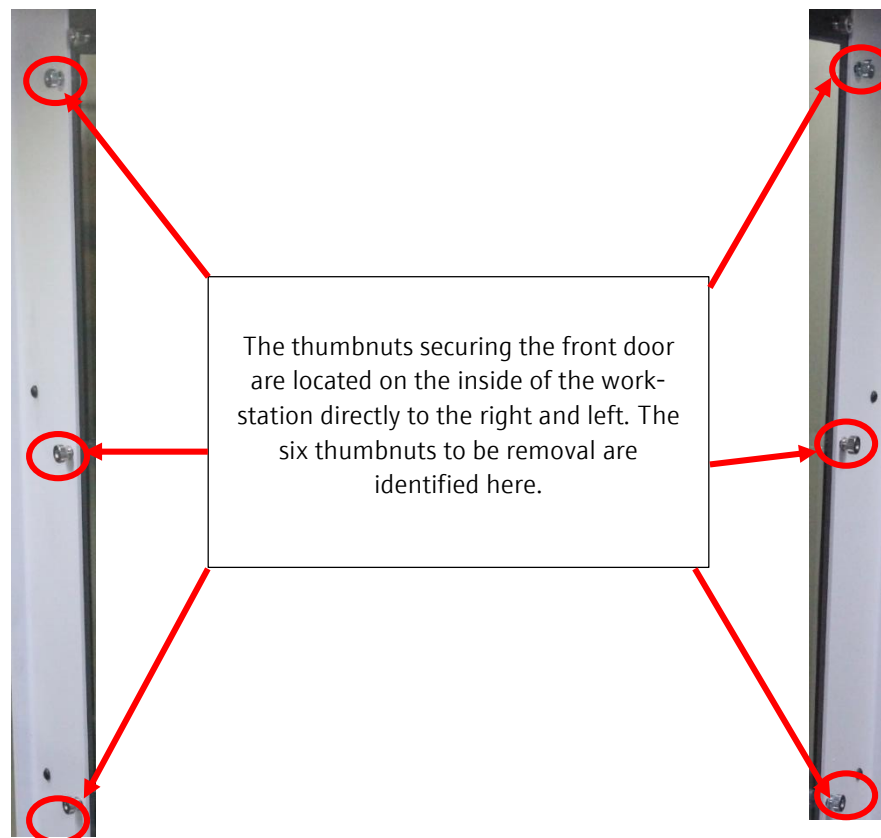

Thumbnuts securing the front door

3. After the door panel is removed, locate the 2 UV bulbs on the ceiling of the unit, in the front and rear of the workstation.
4. To remove the UV bulb, gently twist the bulb away from you to release the bulb from the socket.



5. Replace with a new bulb ordered from Analytik Jena US.

8.2 Filter Replacement (HEPA models only)

The UVP PCR HEPA Workstation includes a carbon pre-filter and HEPA filter set-up. The following procedure will guide the replacement of both the carbon pre-filter and the HEPA filter.

8.2.1 Pre-filter Replacement

1. Switch off the unit and unplug the unit from the main socket.
2. The pre-filter is located inside the pre-filter door on the top-left corner of the unit. Locate the pre-filter door on the top-left and lift the door to reveal the carbon pre-filter.

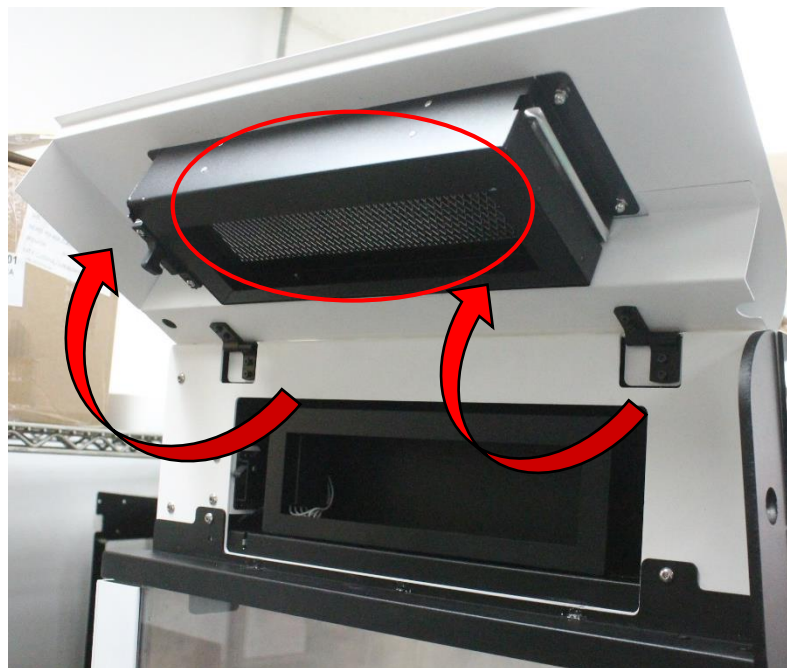

Carbon pre-filter

3. Next, pull to slide the pre-filter out of the compartment.

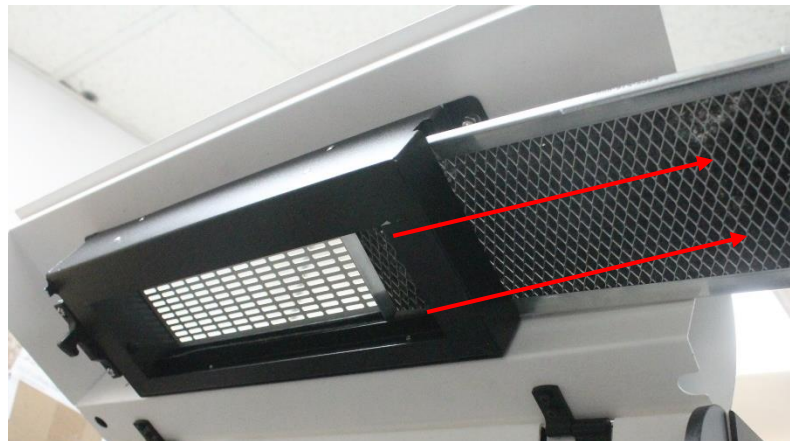

4. Slide the replacement pre-filter into place and close the door till it rests in place.

8.2.2 HEPA filter replacement

1. Begin by removing the front Makrolon panel assembly as outlined in section "UV Bulb Replacement" p. 24.
2. Next, unscrew the three thumbscrews holding the HEPA filter door in place.

Note: It is recommended to unscrew with one hand, and use the other hand to support the door from the bottom to avoid a sudden drop of the door and filter.

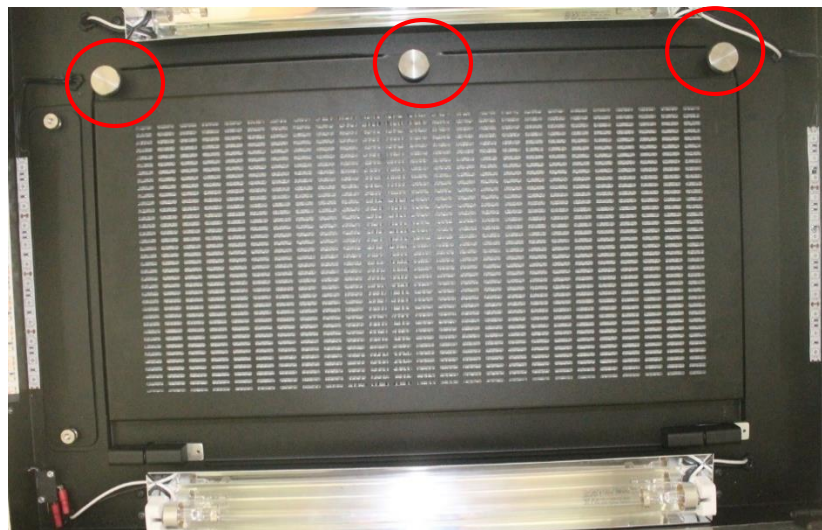

3. Once the thumb screws are removed, gently let the door to drop down. Remove the HEPA filter from the drop-down filter door.

Note: The HEPA filter may require some effort to remove since the filter door seals around the metal housing of the HEPA filter.



4. Once the filter is removed, place the new filter into the drop-down filter door.

Note: It may require some effort to get the HEPA filter to seal properly. It is best to push the filter in from right to left.



5. Once the new HEPA filter is securely placed inside the door, push up the filter door all the way and secure it with the three thumbscrews.
6. Replace the front door Makrolon panel assembly of the workstation and resume normal use.
7. Be sure to follow your lab's specific procedures regarding decontamination and isolation while changing the PCR workstation filters.

8.3 Replacement Parts

The following replacement parts are available for order from Analytik Jena US:

Part Number	Part
17-0151-01	HEPA filter
17-0152-01	Carbon pre-filter
34-0073-01	UV lamp 254 nm, 25W
20-1985-01	Shelf
849-98-0125-01	Makrolon® replacement kit