

REV	ECO	DESCRIPTION	DATE	DFTM	CHKD
D	000035	UPDATED DRAWING	05/31/2019	LS	BK

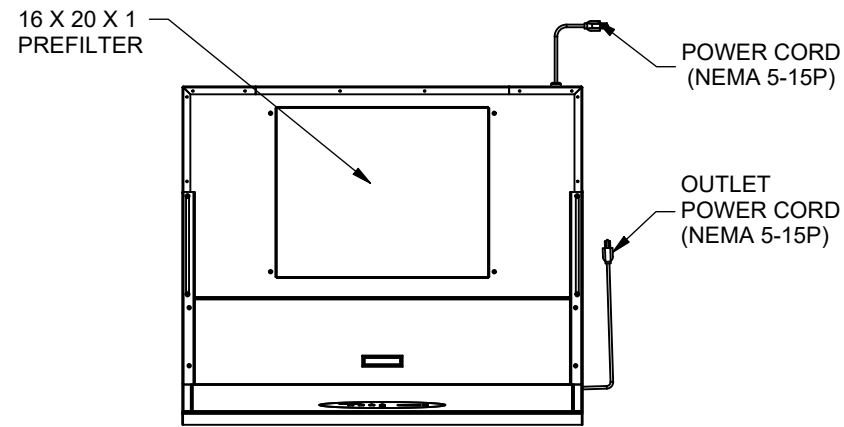

MODEL DIMS			
MODEL	DIM "A"	DIM "C"	HEPA FILTER SIZE
NU-240-330	32 [813]	55 3/8 [1407]	34 [864] X 30 [762] X 3 [76]
NU-240-336	38 [965]	61 3/8 [1559]	34 [864] X 36 [914] X 3 [76]

NU-240-300 BASESTAND DIMENSION OPTIONS				
BASESTAND MODEL	BASESTAND TYPE	DIM "B" (TOTAL)	DIM "D" (BASESTAND)	FILTER SIZE
NU-200-133	TELESCOPING, LEG LEVELERS	81 7/8[2080] TO 89 7/8[2282]	26 1/2[673] TO 31 1/2[876]	30"
NU-200-137	TELESCOPING, CASTERS	82 1/8[2086] TO 90 1/8[2289]	26 3/4[680 TO 34 3/4[883]	30"
NU-200-147 (115V) / NU-200-148 (230V)	AUTOLIFT, LEG LEVELERS	83 5/8[2124] TO 94 5/8[2403]	28 1/4[718] TO 39 1/4[997]	30"
NU-200-149 (115V) / NU-200-150(230V)	AUTOLIFT, CASTERS	83 1/4[2115] TO 94 1/4[2394]	27 7/8[708] TO 38 7/8[987]	30"
NU-200-133	TELESCOPING, LEG LEVELERS	87 7/8[2232] TO 95 7/8[2435]	26 1/2[673] TO 31 1/2[876]	36"
NU-200-137	TELESCOPING, CASTERS	88 1/8[2238] TO 96 1/8[2442]	26 3/4[680 TO 34 3/4[883]	36"
NU-200-147 (115V) / NU-200-148 (230V)	AUTOLIFT, LEG LEVELERS	89 5/8[2276] TO 100 5/8[2556]	28 1/4[718] TO 39 1/4[997]	36"
NU-200-149 (115V) / NU-200-150 (230V)	AUTOLIFT, CASTERS	89 1/4[2267] TO 100 1/4[2546]	27 7/8[708] TO 38 7/8[987]	36"

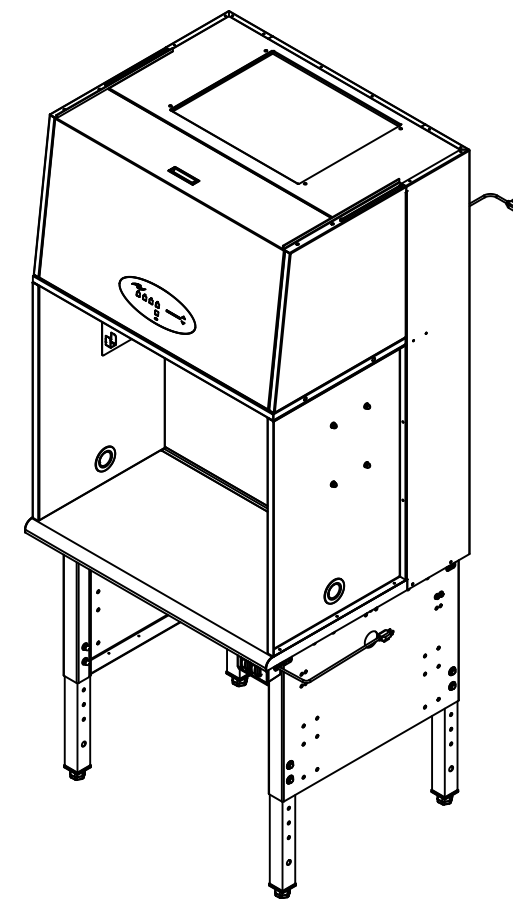
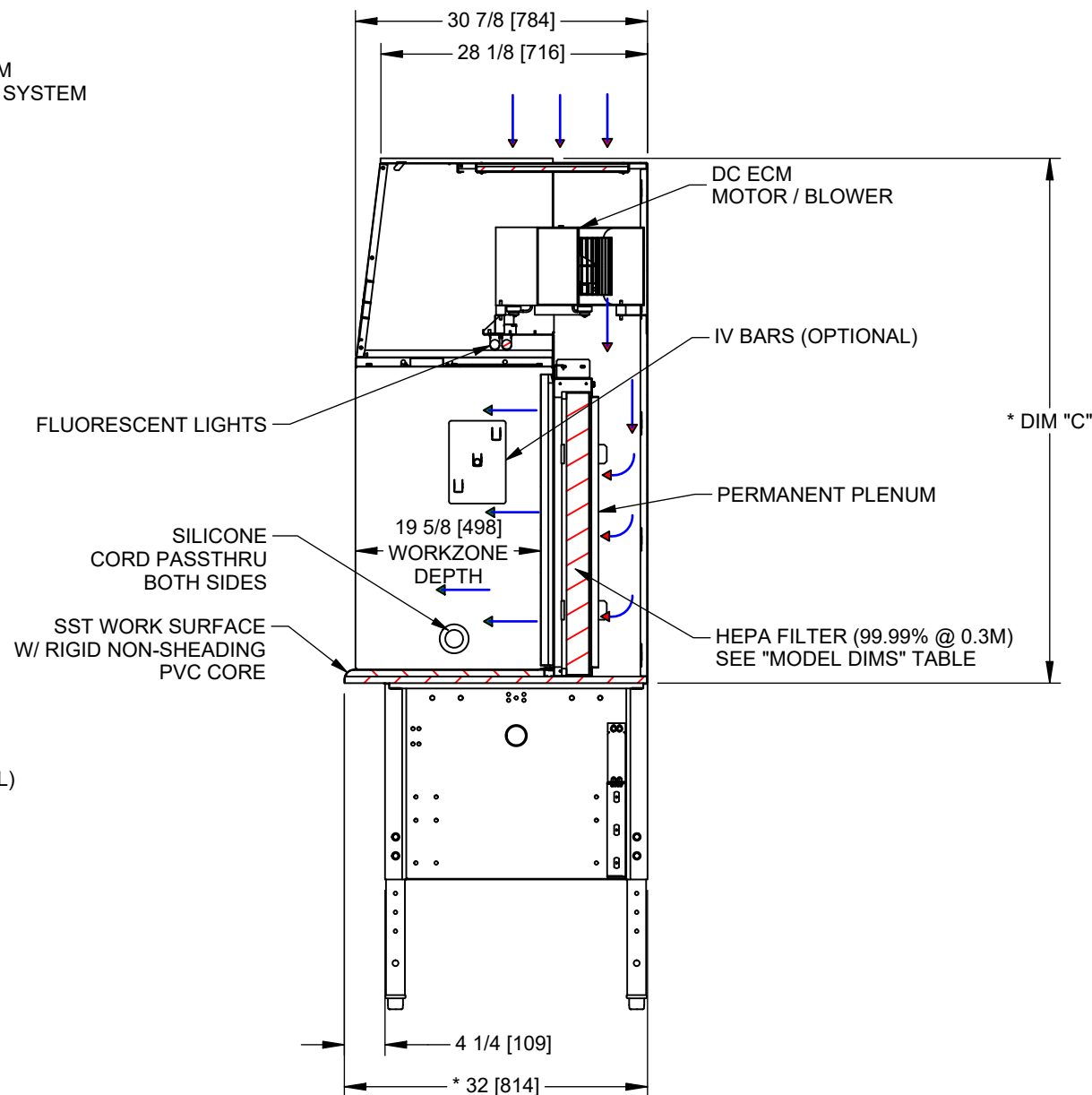
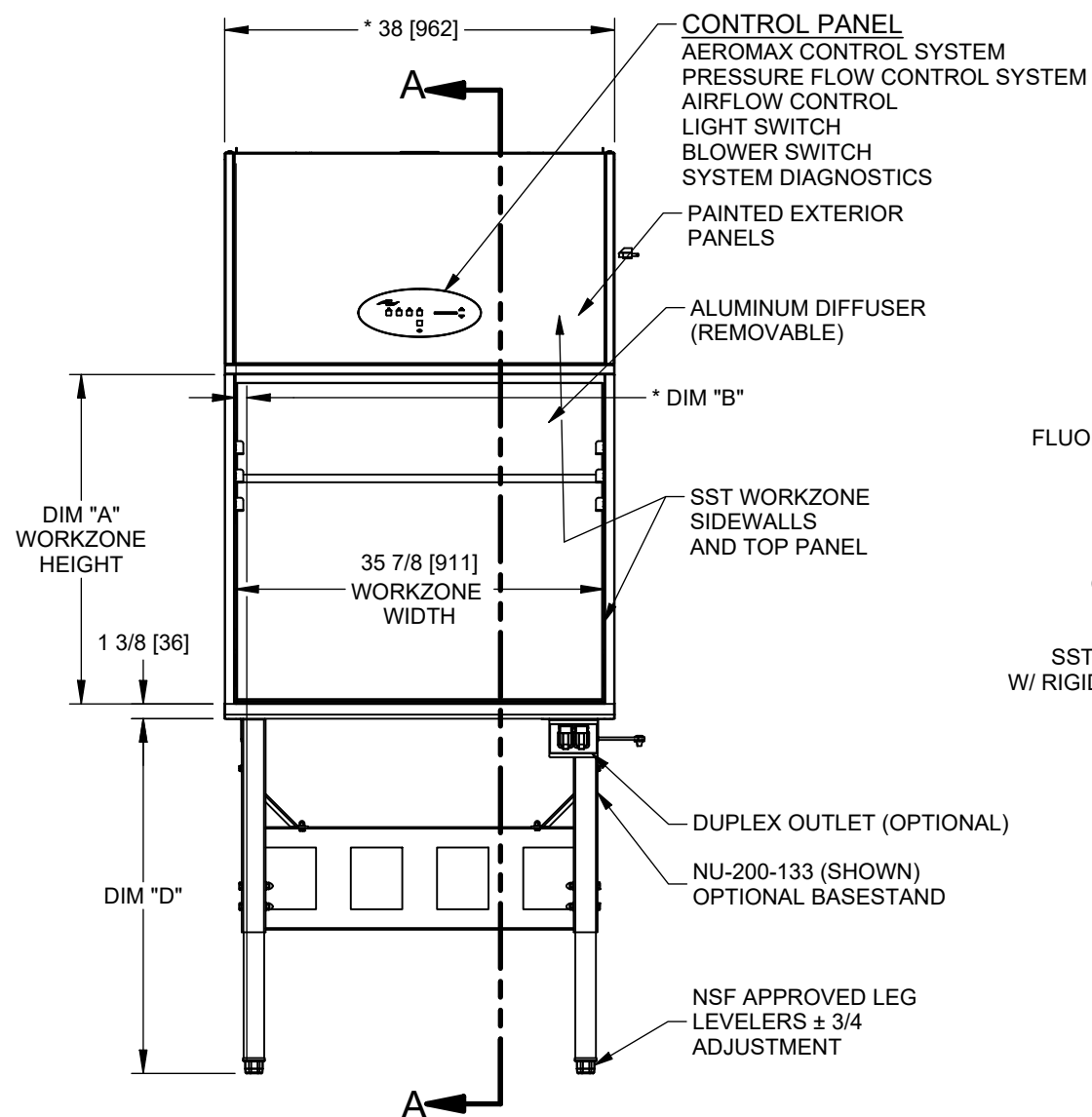

* OVERALL DIMENSIONAL TOLERANCE ±1/4" [6.35]
ALL OTHER DIMENSIONS ±1/8" [3.17]

TITLE Horizontal Airflow Specs NU-240-300				
DFTM LS	DATE 3/12/2018	CHKD BP	SHEET 1	OF 1
DRAWING NUMBER BCD-19800		D		

SECTION A-A

INCH
MILLIMETER