

REV	ECO	DESCRIPTION	DATE	DFTM	CHKD
D	000035	UPDATED DRAWING	05/31/2019	LS	BK

16 X 20 X 1
PREFILTERS

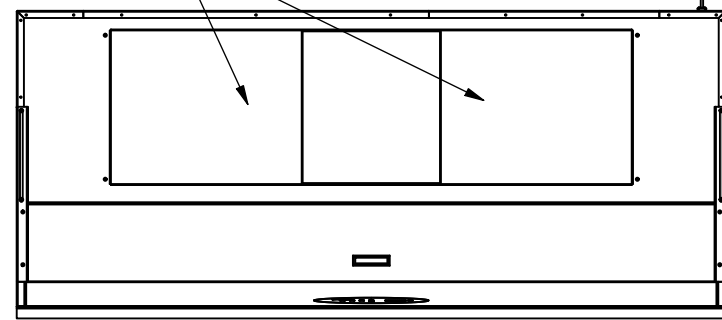

POWER CORD
(NEMA 5-15P)

OUTLET
POWER CORD
(NEMA 5-15P)

MODEL DIMS			
MODEL	DIM "A"	DIM "C"	HEPA FILTER SIZE
NU-240-630	32 [813]	55 3/8 [1407]	70 [1778] X 30 [762] X 3 [76]

NU-240-600 BASESTAND DIMENSION OPTIONS

BASESTAND MODEL	BASESTAND TYPE	DIM "B" (TOTAL)	DIM "D" (BASESTAND)	FILTER SIZE
NU-200-136	TELESCOPING, LEG LEVELERS	81 7/8[2080] TO 89 7/8[2282]	26 1/2[673] TO 31 1/2[876]	30"
NU-200-140	TELESCOPING, CASTERS	82 1/8[2086] TO 90 1/8[2289]	26 3/4[680] TO 34 3/4[883]	30"
NU-200-159 (115V) / NU-200-160 (230V)	AUTOLIFT, LEG LEVELERS	83 5/8[2124] TO 94 5/8[2403]	28 1/4[718] TO 39 1/4[997]	30"
NU-200-161 (115V) / NU-200-162 (230V)	AUTOLIFT, CASTERS	83 1/4[2115] TO 94 1/4[2394]	27 7/8[708] TO 38 7/8[987]	30"

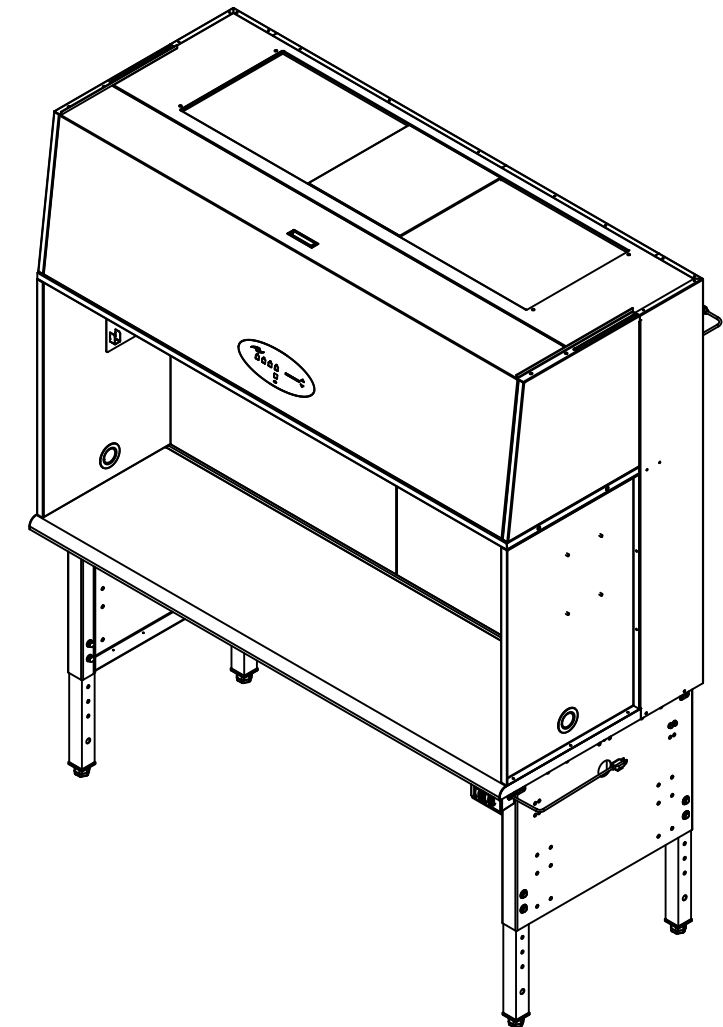
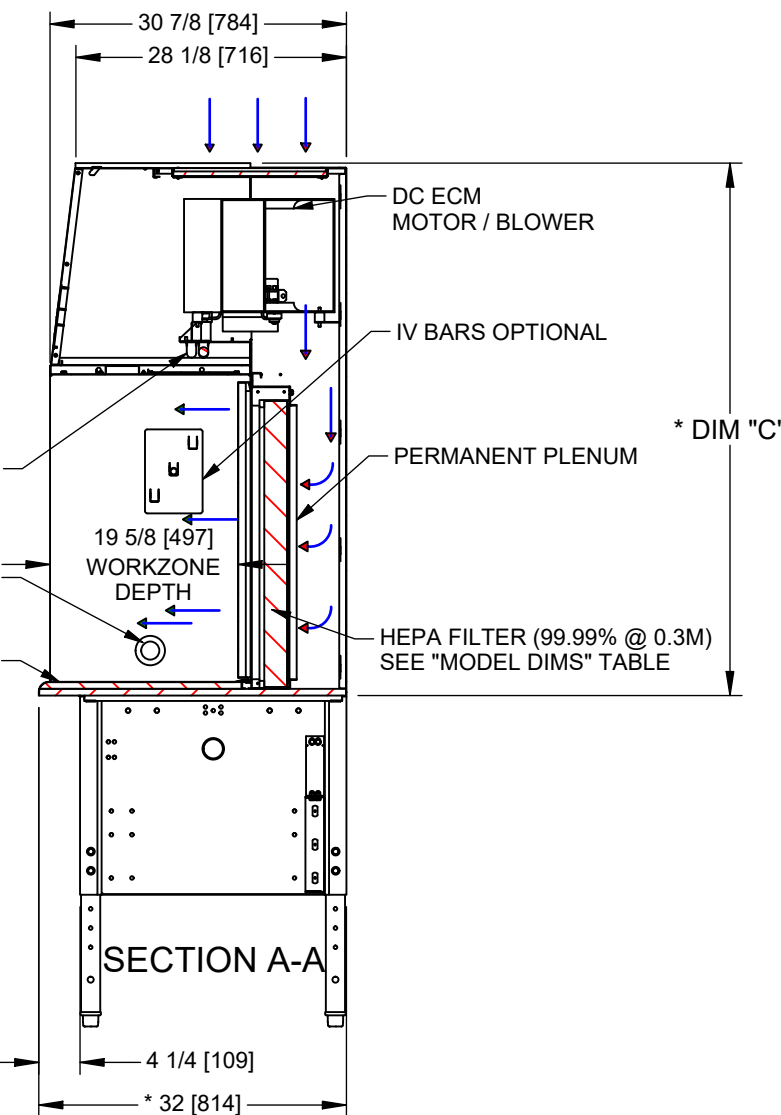
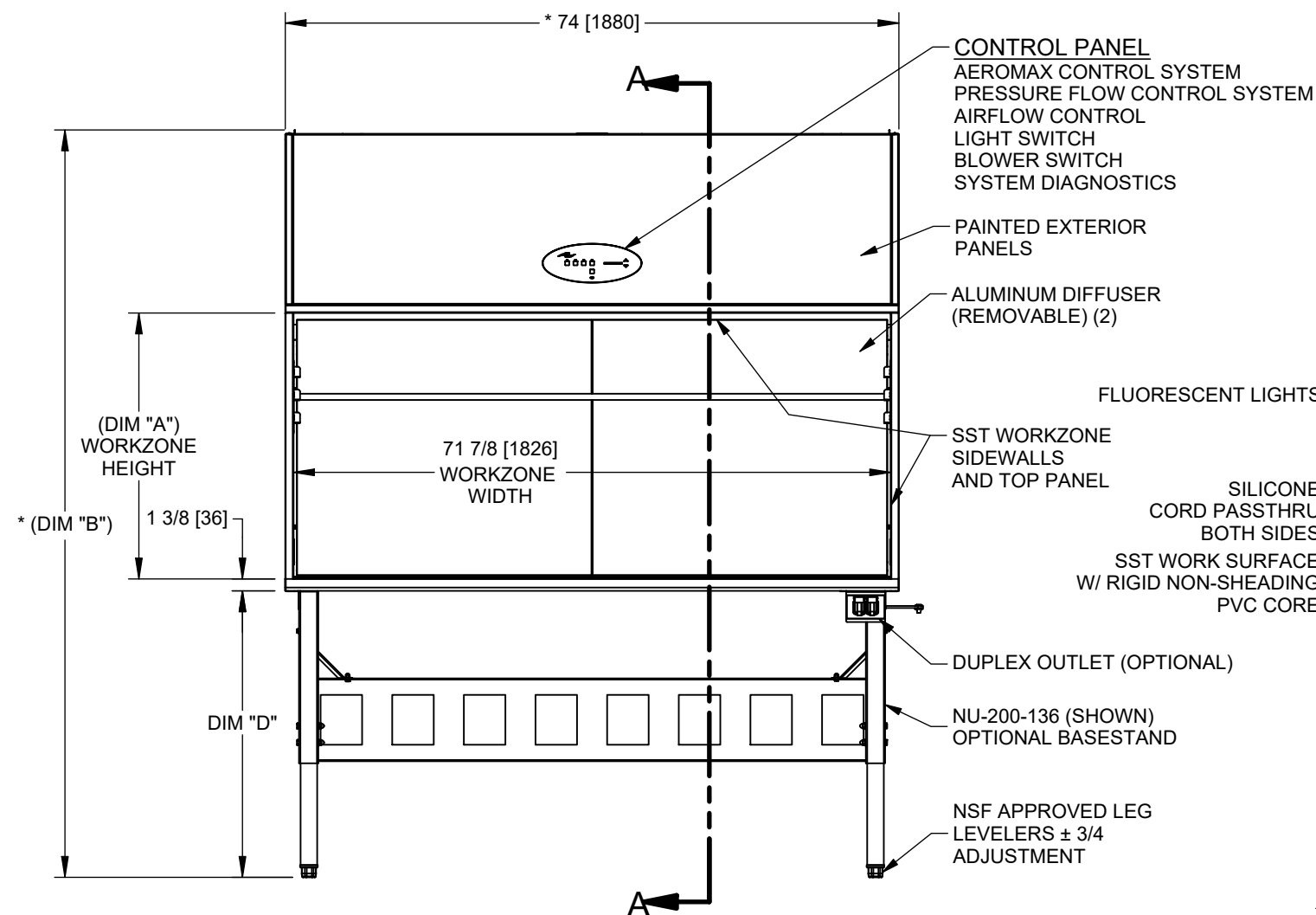

* OVERALL DIMENSIONAL TOLERANCE ±1/4" [6.35]
ALL OTHER DIMENSIONS ±1/8" [3.17]

TITLE Horizontal Airflow Specs NU-240-600					
DFTM LS	DATE 3/8/2018	CHKD BP	SHEET 1	OF 1	
DRAWING NUMBER		BCD-19666			D

INCH
MILLIMETER