

REV	ECO	DESCRIPTION	DATE	DFTM	CHKD
B	13550	CORRECTED TYPO	11/28/2017	TH	BP

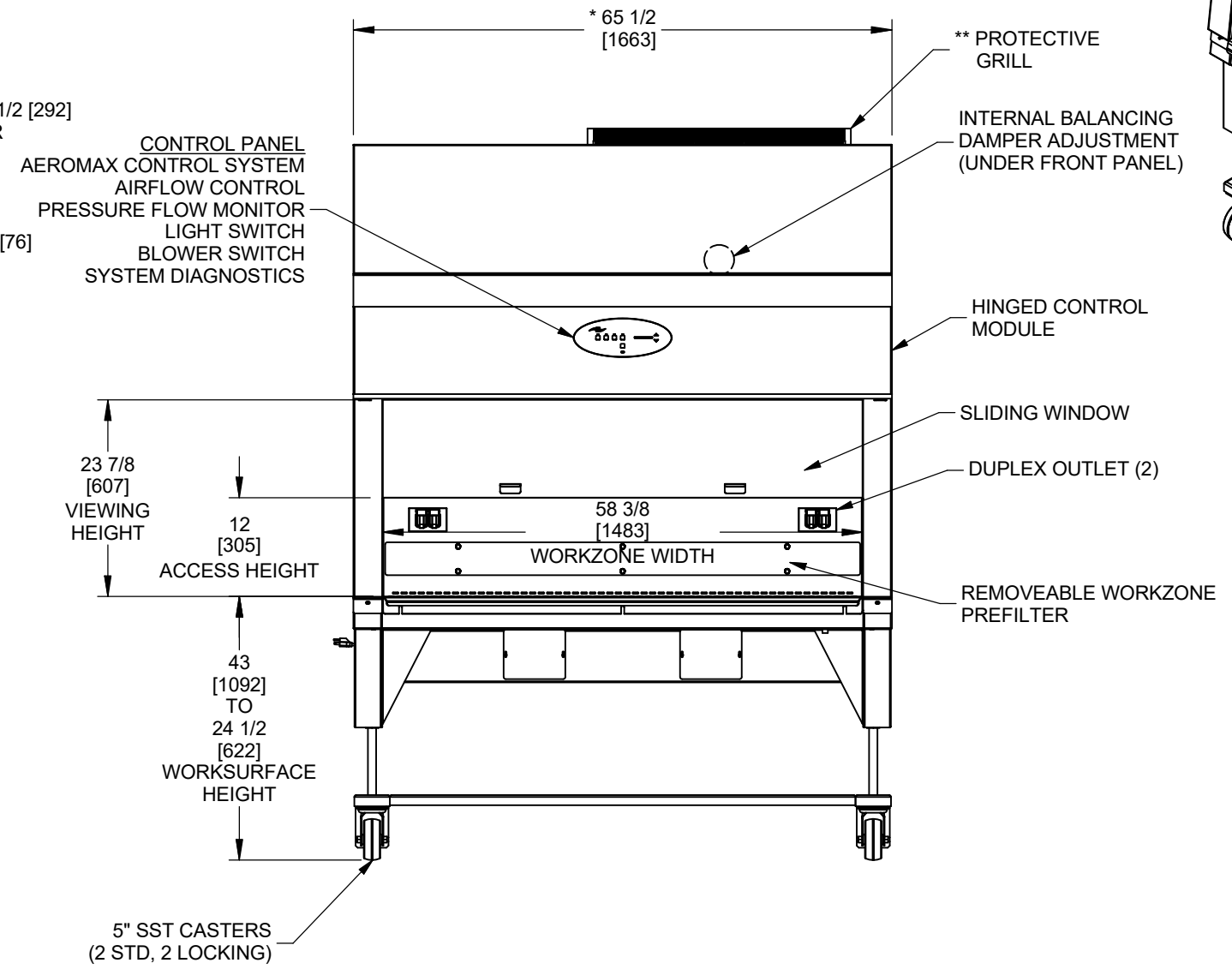
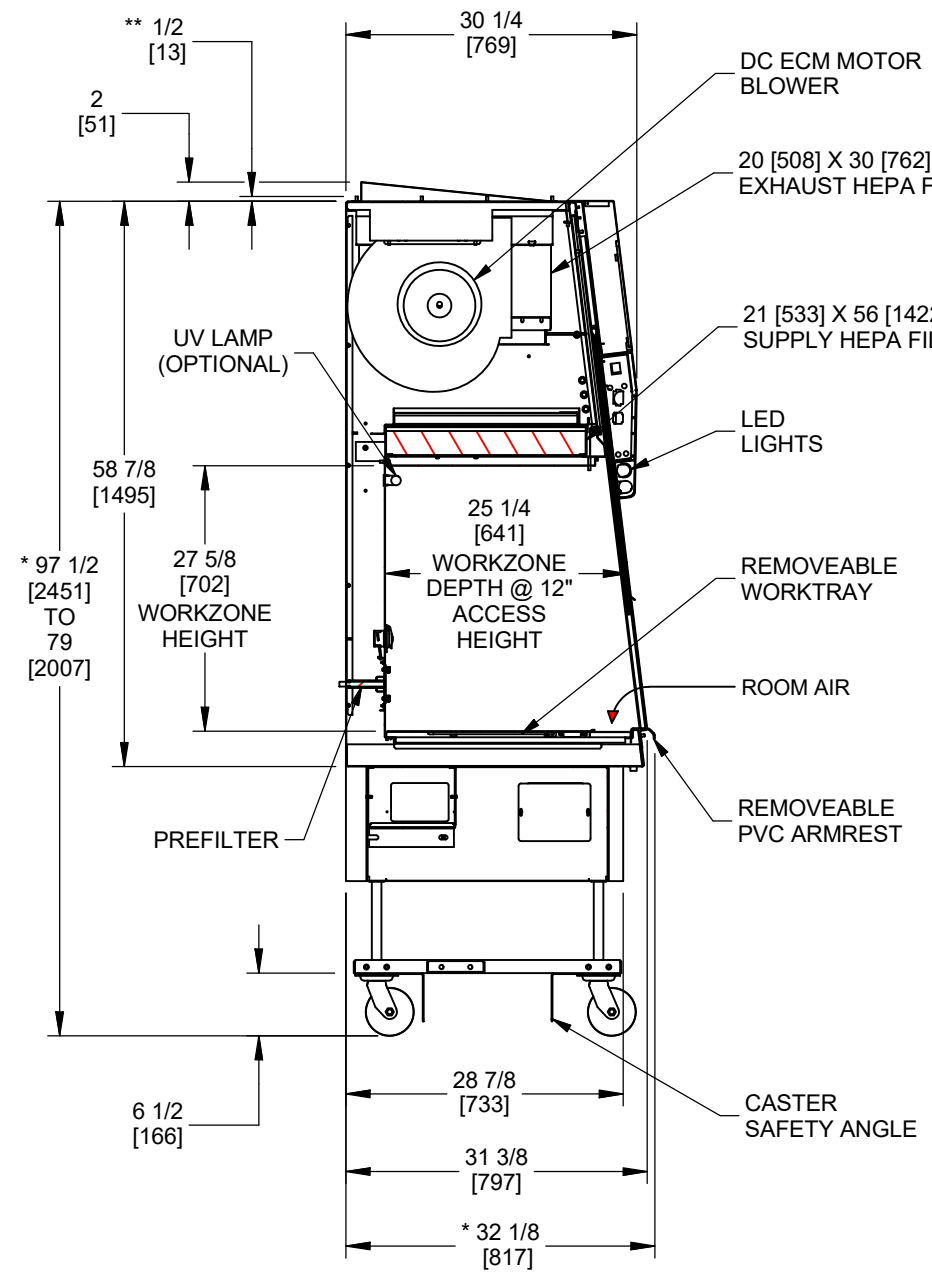
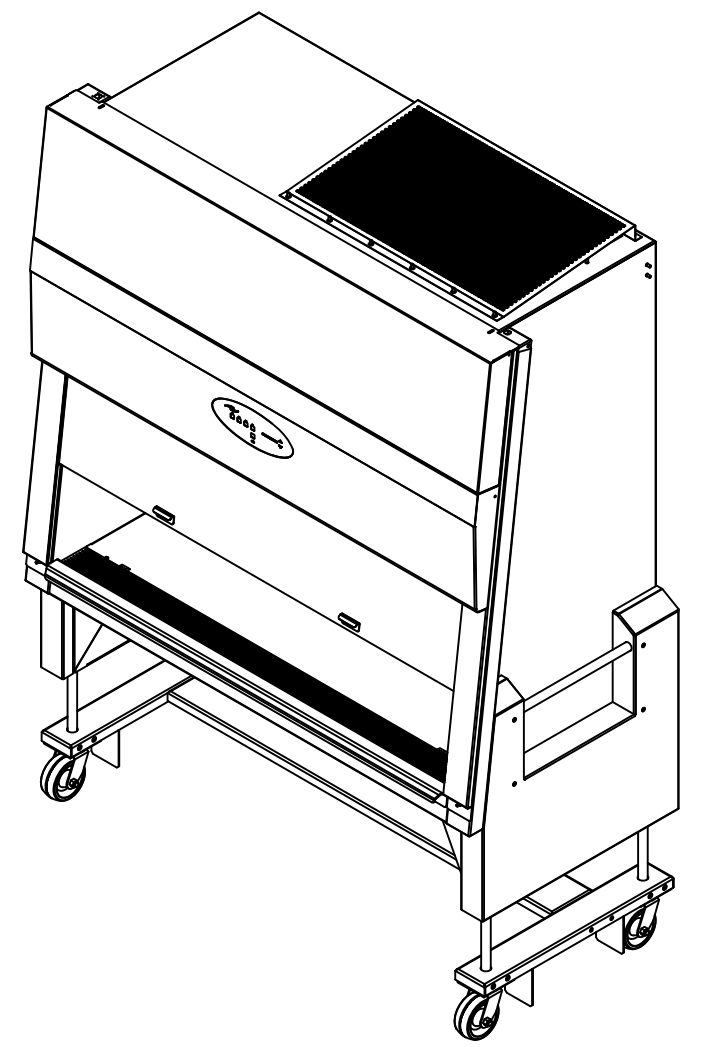
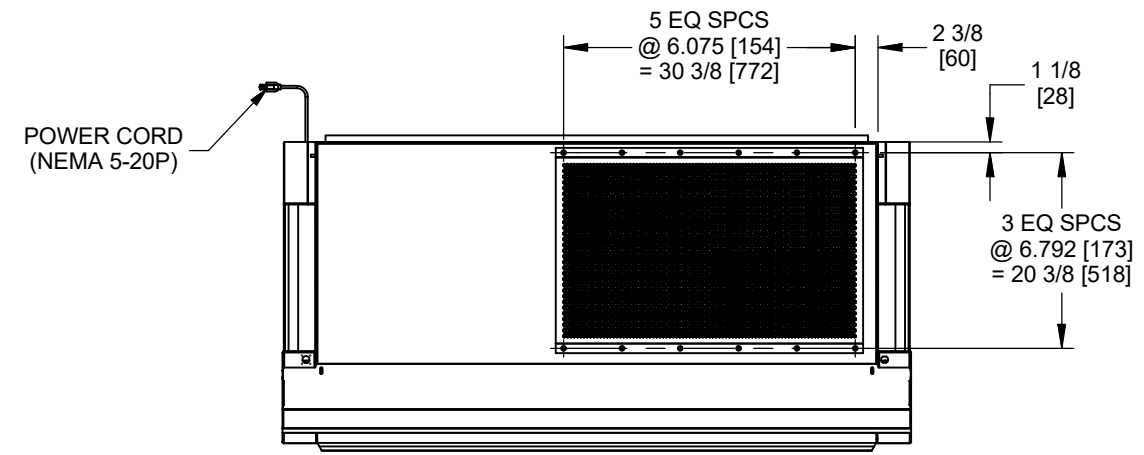

*OVERALL DIMENSIONAL TOLERANCE ±1/4 [6.35]
ALL OTHER DIMENSIONS ±1/8 [3.17]

** ADD 1/2' [76] TO OVERALL HEIGHT WITH PROTECTIVE GRILL REMOVED

INCH
MILLIMETER

TITLE NU-677-500 CLASS II TYPE A2 (ENERGY SAVER) ANIMAL HANDLING BIOLOGICAL SAFETY CABINET					
DFTM LS	DATE 6/7/2017	CHKD BP	SHEET 1	OF 1	
DRAWING NUMBER			BCD-19123		B