

REV	ECO	DESCRIPTION	DATE	DFTM	CHKD
B	13550	CORRECTED TYPO	11/28/2017	TH	BP

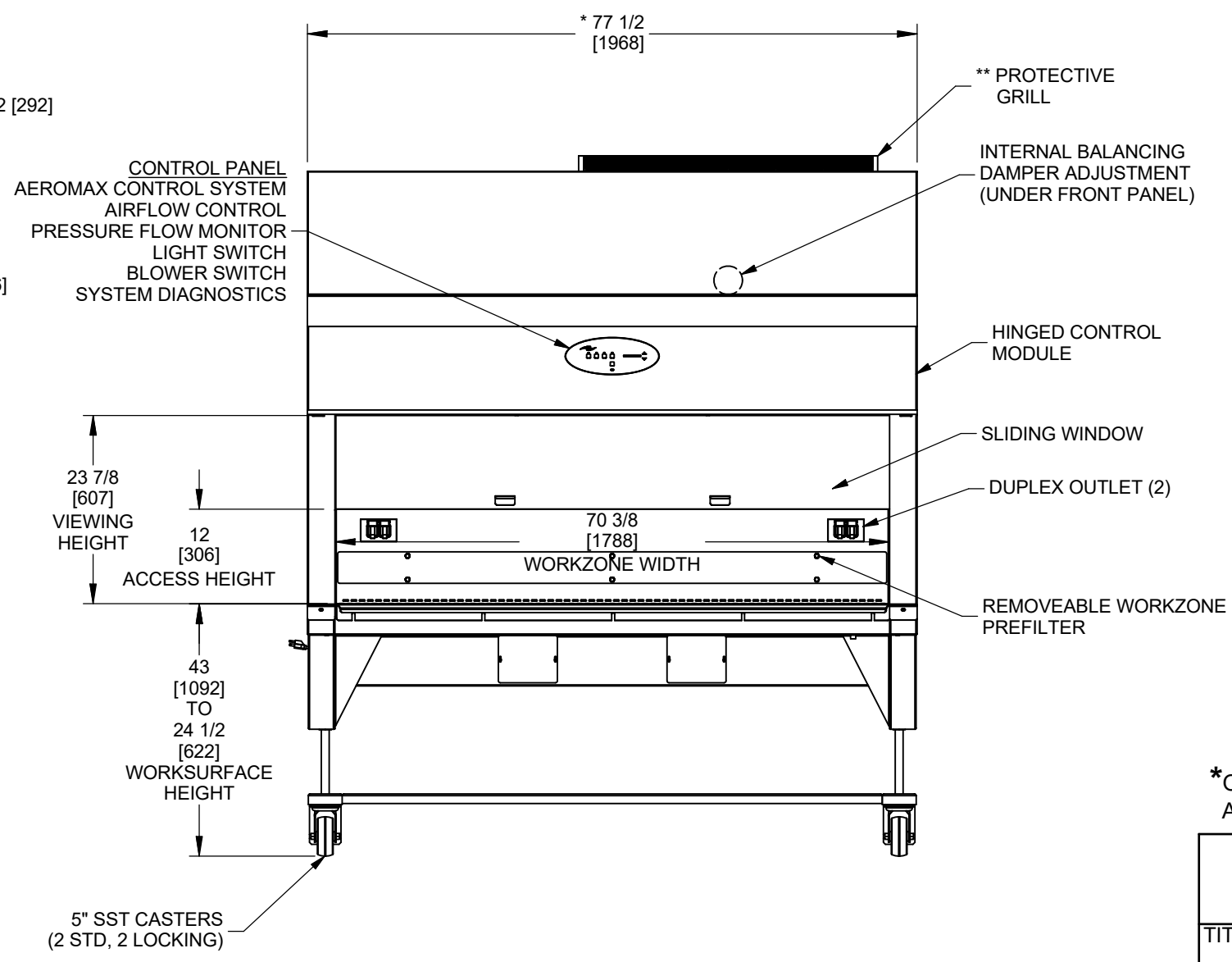
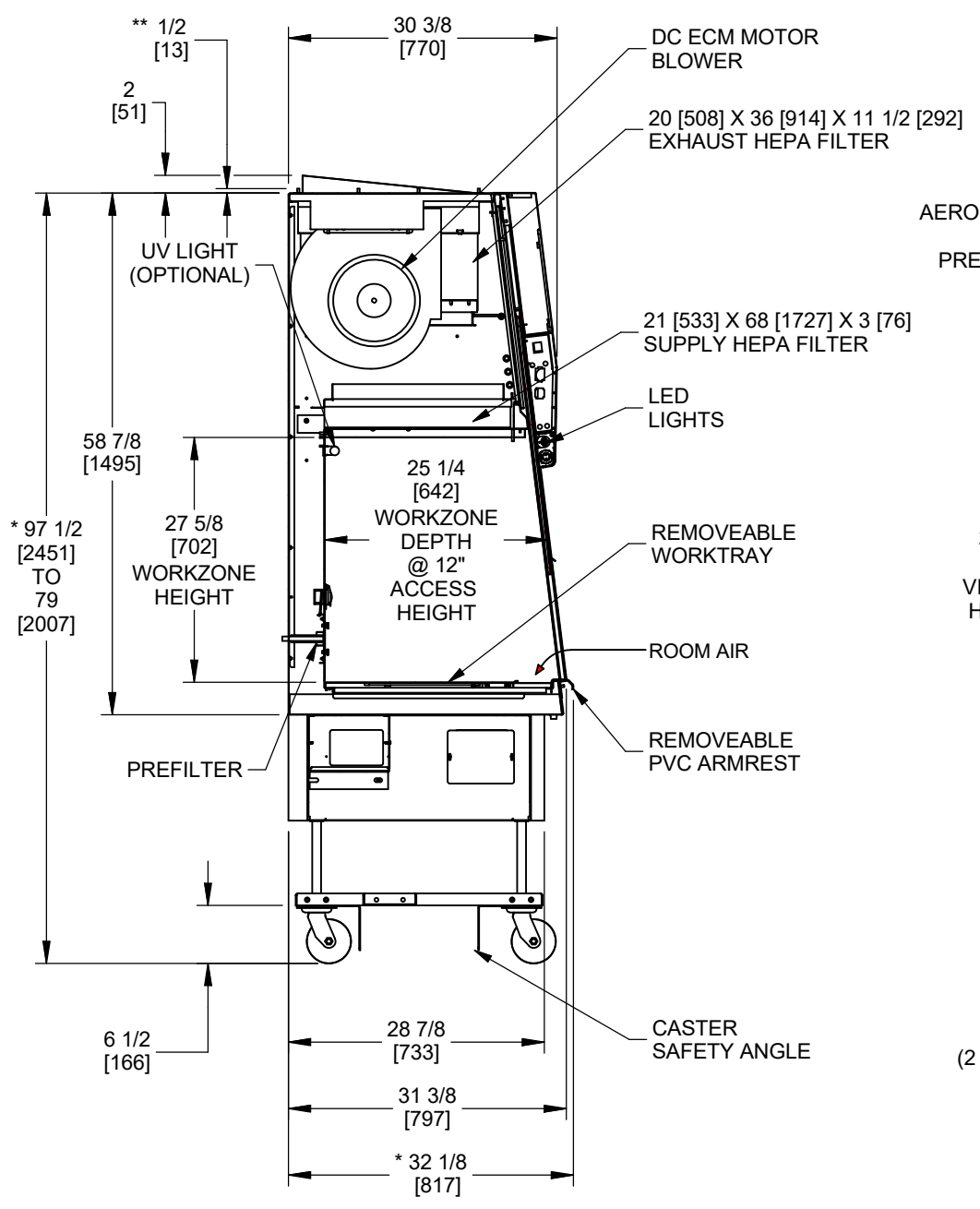
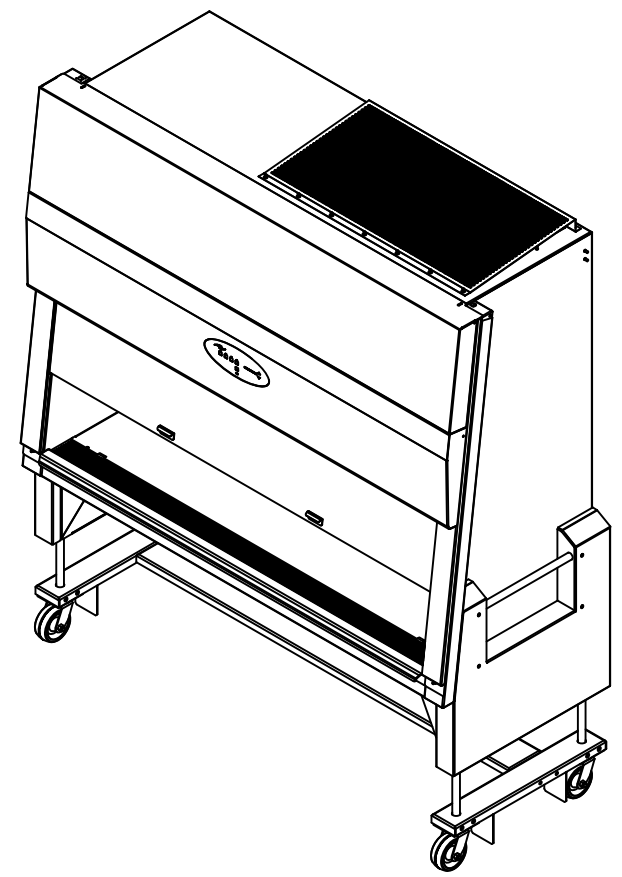
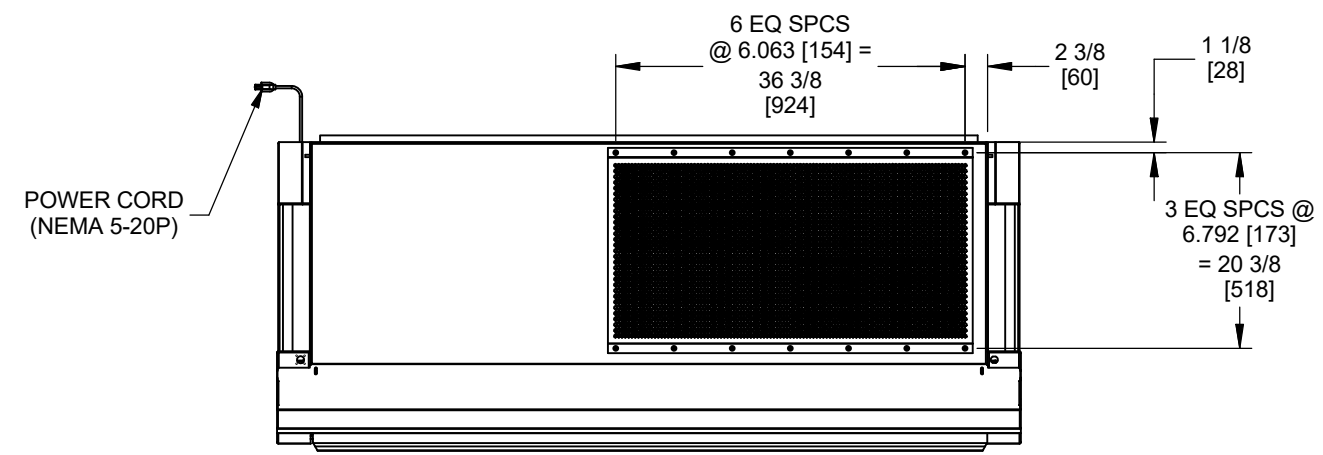

* OVERALL DIMENSIONAL TOLERANCE ±1/4 [6.35]
 ALL OTHER DIMENSIONS ±1/8 [3.17]

TITLE NU-677-600 CLASS II TYPE A2 (ENERGY SAVER) ANIMAL HANDLING BIOLOGICAL SAFETY CABINET					
DFTM LS	DATE 6/7/2017	CHKD BP	SHEET 1	OF 1	
DRAWING NUMBER BCD-19124			B		

** ADD 1/2' [76] TO OVERALL HEIGHT WITH PROTECTIVE GRILL REMOVED

INCH
MILLIMETER