

REV	ECO	DESCRIPTION	DATE	DFTM	CHKD
C	13915	UPDATED VIEWS, CORRECTED / ADDED DIMENSIONS	1/7/2019	TH	MSS

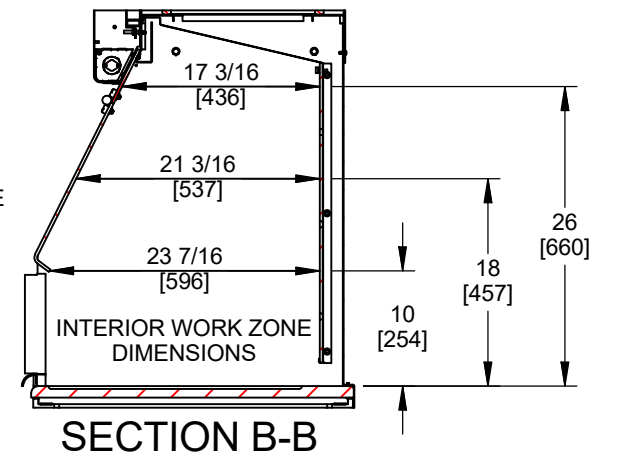
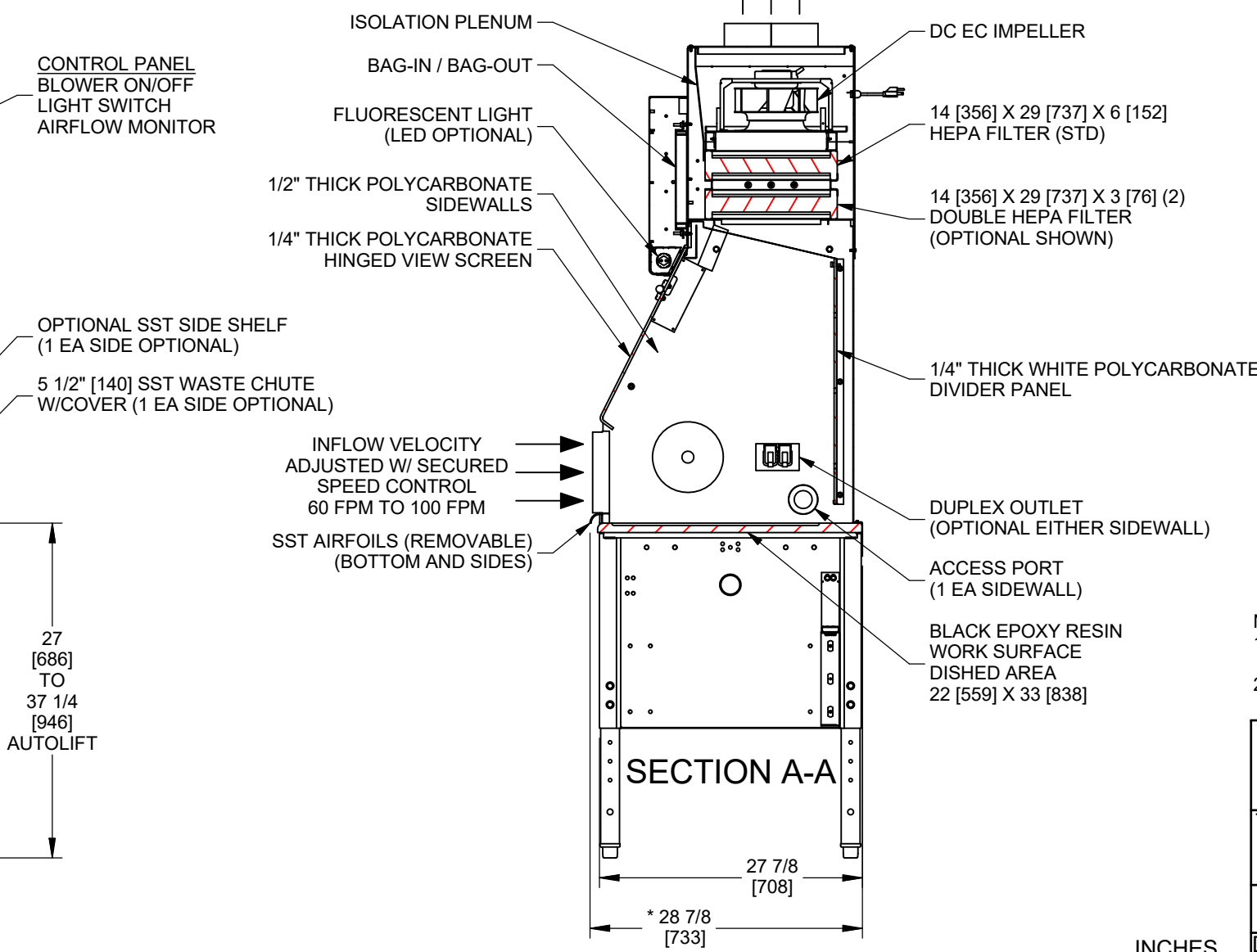
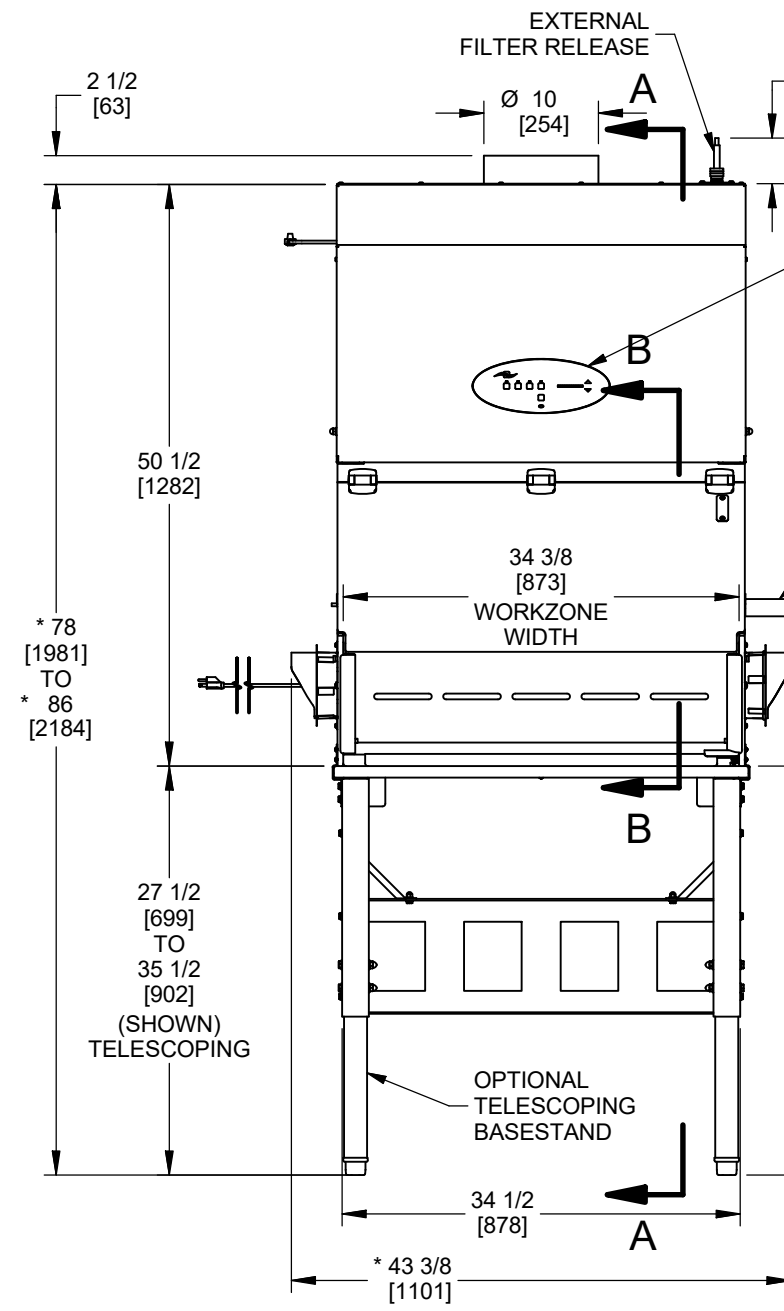
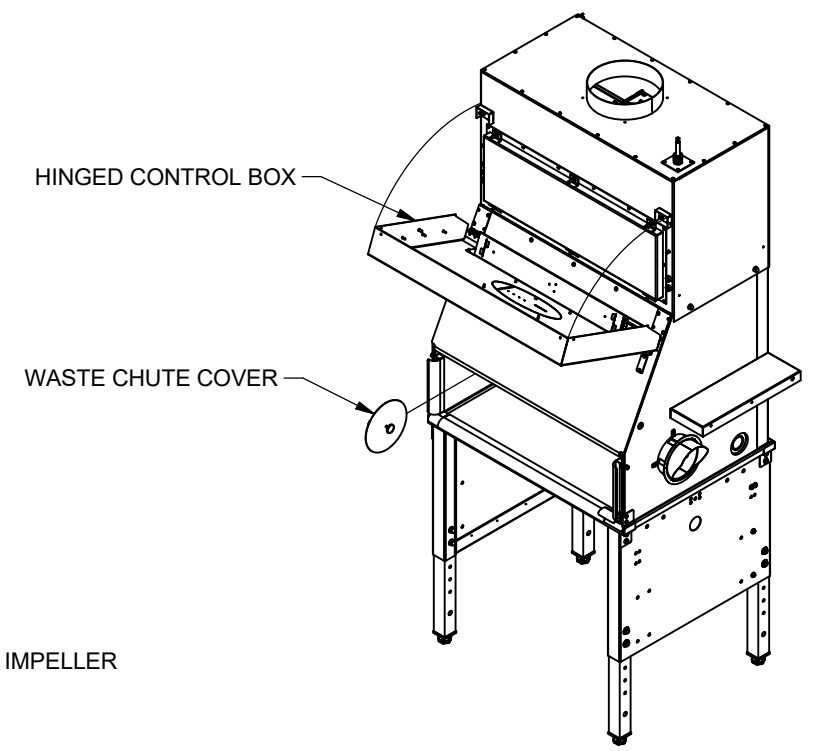
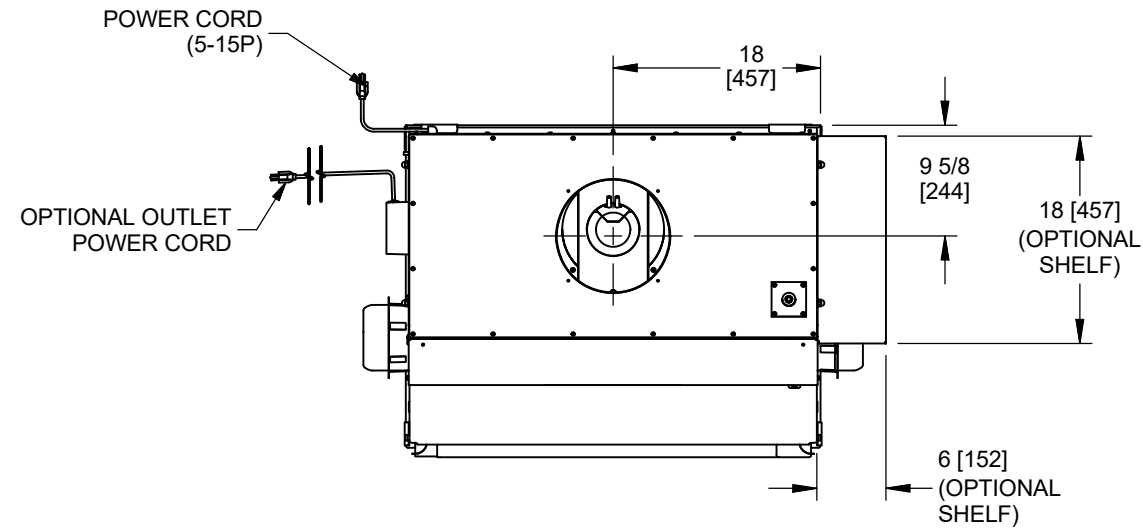

NOTES:
 1. * OVERALL DIMENSIONAL TOLERANCE ± 1/4 [6.35] ALL OTHER DIMENSIONS ± 1/8 [3.17]
 2. ALL ITEMS STANDARD UNLESS OTHERWISE SPECIFIED AS OPTIONAL.

TITLE NU-813-300 SERIES 33 CONTAINMENT VENTILATED ENCLOSURE					
DFTM LS	DATE 11/16/2016	CHKD MSS	SHEET 1	OF 1	
DRAWING NUMBER			BCD-18729		C

INCHES
MILLIMETER