

CUTSHEET

Front View

Side View

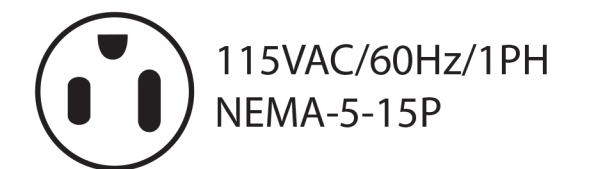
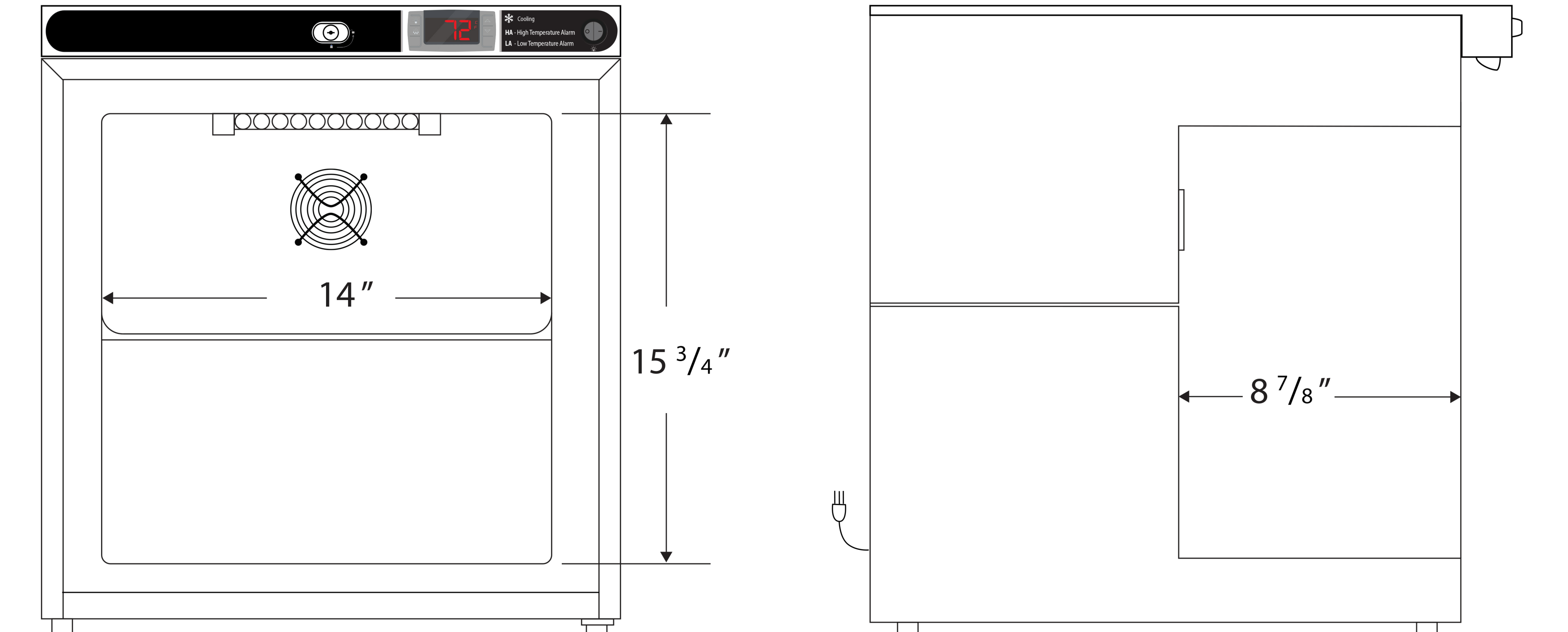

Cu. Ft	Defrost	Door	Int Door	Shelves	Interior Dim.			Refrigerant	H.P.	Amps	Weight
					W"	D"	H"				
1	Cycle	1 Glass (Reversible)	0	2 Adj	14	8 7/8	15 3/4	R600a	1/8	.90	63 lbs.

Note: Interior dimensions are estimates and subject to change without notice