

**LabGard™ ES HD Energy Saver  
Class II, Type A2 Laminar Flow  
Biosafety Cabinet**

**Models  
NU-581-400/500/600  
Console**

**Operation & Maintenance Manual**

**July, 2019  
Revision 3  
S-1**



**Manufactured By:**  
NuAire, Inc.  
2100 Fernbrook Lane  
Plymouth, MN 55447  
Toll-Free: 1-800-328-3352  
In Minnesota: (763)-553-1270  
Fax: (763)-553-0459

## **Congratulations!**

You have just purchased one of the finest Laminar Flow Biosafety Cabinets available. With proper care, maintenance (certification), and laboratory procedure, this cabinet will give you years of product and personnel protection from particulate contaminants as prescribed in NSF/ANSI. Please read this manual carefully to familiarize yourself with proper installation, maintenance and operation of the cabinet. Other reference and guideline materials are available through the following web sites.

[www.hc-sc.gc.ca](http://www.hc-sc.gc.ca)  
[www.cdc.gov/od/ohs/](http://www.cdc.gov/od/ohs/)  
[www.absa.org](http://www.absa.org)  
[www.absa-canada.org](http://www.absa-canada.org)  
[www.ebsa.be](http://www.ebsa.be)  
[www.inspection.gc.ca](http://www.inspection.gc.ca)  
[www.who.int](http://www.who.int)  
[www.biosafety.be](http://www.biosafety.be)  
[www.hse.gov.uk](http://www.hse.gov.uk)  
[www.nsf.org](http://www.nsf.org)  
[www.cetainternational.org](http://www.cetainternational.org)  
[www.nuaire.com](http://www.nuaire.com)

## **ABOUT THIS OPERATION & MAINTENANCE MANUAL**

The information contained in this manual is intended to reflect our current production standard configuration model along with the more frequently purchased options. Any unique additions/modifications/shop drawings are appended in the back flap of this manual, along with any modifications and/or additions to procedures as outlined in this manual. A copy of the original factory test report is also appended to this manual. In case this manual and/or test report is lost or misplaced, NuAire retains a copy in our files. A replacement copy can be obtained by calling or writing NuAire, Inc. stating the model number and serial number and a brief description of the information desired.

**LabGard™ ES HD Energy Saver**  
**Class II, Type A2 Laminar Flow Biosafety Cabinet**  
Models NU-581-400/500/600  
Operation & Maintenance Manual

**TABLE OF CONTENTS**

Section No. 1.....	General Information
Section No. 2.....	Models & Features
Section No. 3.....	Warranty
Section No. 4.....	Shipments
Section No. 5.....	Installation Instructions
5.1.....	Location
5.2.....	Set-up Instructions
5.3.....	Testing Methods and Equipment
Section No. 6.....	Operating the NU-581
6.1.....	Biosafety Cabinet Control
6.2.....	Operating Guidelines
6.3.....	Operating Sequence
6.4.....	Ergonomics
6.5.....	Cleaning Procedures
Section No. 7.....	General Maintenance
7.1.....	Decontamination
7.2.....	Fluorescent Lamp Bulb Replacement
7.3.....	Primary HEPA Prefilter Replacement
7.4.....	Secondary HEPA Filter/Motor Replacement
7.5.....	Sliding Window Replacement & Manual Adjustment
7.6.....	Airflow Control System Setup & Calibration
7.7.....	HEPA Filter Leak Tests
7.8.....	Airflow Smoke Pattern Test
7.9.....	Cleanliness Classification Test for Pharmacy Application
7.10.....	Main Control Board Description & Replacement
7.11.....	Digital Airflow Sensor Description & Replacement
Section No. 8.....	Error Messages, Troubleshooting, Option-Diagnostics & Airflow Sensor Performance Verification
Section No. 9.....	Remote Contacts
Section No. 10.....	Optional Equipment
10.1.....	Ultraviolet Light
Section No. 11.....	Electrical/Environmental Requirements
Section No. 12.....	Disposal and Recycle
Insert.....	Replacement Parts, Warranty

**MANUAL DRAWINGS**

ACD-19747.....	NU-581 Airflow Schematic
BCD-19748.....	NU-581-400 Specification Drawing
BCD-19749.....	NU-581-500 Specification Drawing
BCD-19750.....	NU-581-600 Specification Drawing
BCD-16509.....	Auto Decontamination Setup

**ASSEMBLY DRAWINGS**

BCD-11817.....	Control Center & Front Decorative Panel Assembly
BCD-11686.....	Sliding Window Assembly & Adjustment
BCD-13923.....	NU-581 Manual Base Adjustment
BCD-12271.....	NU-581 Window Assembly Hinge Operation
BCD-12281.....	Auto Window Switch/Cable Adjustment and Maintenance
BCD-12282.....	Auto Window Cable and Window Assembly

**ELECTRICAL SCHEMATICS**

BCD-19751.....	NU-581-400/500/600 Electrical Schematic
----------------	---

**LabGard™ ES HD Energy Saver  
Class II, Type A2 Laminar Flow  
Biosafety Cabinet  
Models  
NU-581-400/500/600  
MANUFACTURED BY:  
NuAire, Inc. - Plymouth, Minnesota, U.S.A.**

## **1.0 General Information**

### **1.1 Description**

The LabGard™ ES HD Model NU-581 Laminar Flow Biosafety Cabinet (LFBSC) is a console model. The LabGard™ ES HD Model NU-581 utilizes an Energy Saver DC ECM Motor optimally determined forward curved fan for each model size/width to maximize both energy efficiency and filter loading capacity. The Energy Saver ECM Motor is controlled to airflow setpoints via a solid-state DC motor controller with digital dual thermistor airflow sensors that provide an automatic compensation (constant volume control) for both filter loading and line voltage variances.

The Laminar Flow Biosafety Cabinet, (LFBSC) is a product resulting from the development of the "laminar flow" principle (see Airflow Schematic) and the application of environmental controls as required in the field of biological research or chemical (hazardous drugs) containment. The LFBSC, when used with proper technique, is an effective primary engineering control in obtaining the optimum product quality while reducing the potential for exposure of both product and personnel to airborne biological or particulate chemical (hazardous drugs) agents in low to moderate risk-hazard research and drug preparation or product operations, as prescribed by the Center for Disease Control (CDC) Atlanta, Georgia.

The NU-581 Console LFBSC meets the requirements of a Class II, Type A2 since the cabinet conforms to the following requirements:

1. Maintains a minimum inflow velocity of 100 LFPM (.51mps) through the work access opening
2. Has HEPA filtered downflow air that is mixed with the inflow air from a common exhaust plenum
3. Discharges a percentage of air to the outside atmosphere after HEPA filtration
4. Has all biologically contaminated ducts and plenums under negative pressure or surrounded by negative pressure

Cabinets used for work with minute quantities of non-flammable or explosive volatile toxic chemicals and tracer amounts of radionuclides required as an adjunct to microbiological studies must be exhausted through properly functioning exhaust canopies.

### 1.2 Safety Instructions

These safety instructions describe the safety features of the LabGard™ ES HD Model NU-581 LFBSC.

The safety cabinet has been manufactured using the latest technological developments and has been thoroughly tested before delivery. **However, the cabinet may present potential hazards if it is not installed and used as instructed for its intended purpose or outside of operating parameters.** Therefore, the following procedures must always be observed:

- The safety cabinet must be operated only by trained and authorized personnel.
- For any operation of this cabinet, the operator must prepare clear and concise written instructions for operating and cleaning, utilizing applicable safety data sheets, plant hygiene guidelines, and technical regulations, in particular.
  - which decontamination measures are to be applied for the cabinet and accessories
  - which protective measures apply while specific agents are used
  - which measures are to be taken in the case of an accident
- Repairs to the device must be carried out only by trained and authorized expert personnel.
- Keep these operating instructions close to the cabinet so that safety instructions and important information are always accessible.
- Should you encounter problems that are not detailed adequately in the operating instructions, please contact your NuAire Representative of NuAire technical Services.

### 1.3 Explanation of Symbols



Safety alert symbol indicates a potentially hazardous situation which, if not avoided, could result in death or serious injury.

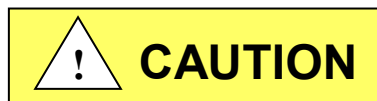

Safety alert symbol indicates a potentially hazardous situation which, if not avoided, may result in minor or moderate injury.

**CAUTION**

CAUTION used without the safety alert symbol indicates a potentially hazardous situation which, if not avoided, may result in property



Potential electrical hazard, only qualified person to access.

 NOTE:

Used for important information.



Biohazard



Ground, Earth



Flammable Hazard



Lead Free





Chemical Hazard

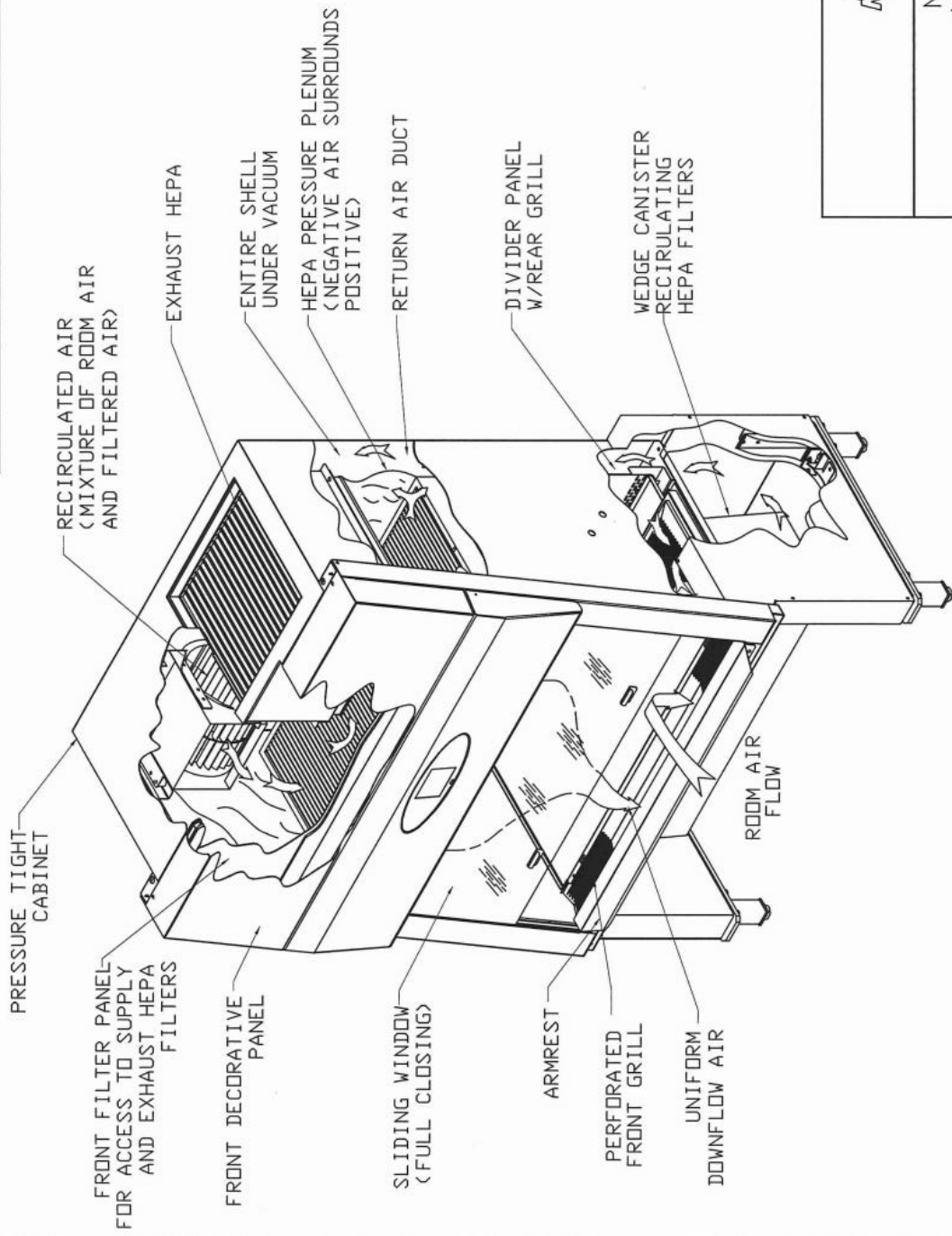

Hazardous Gases! Personal Protection Equipment Required.

REV	ECD	DESCRIPTION	DATE	DRFT	CHKD
A	13685	RELEASED TO PRODUCTION	3/21/2018	TH	BR



		<b>ORIGINAL</b>	
NU-581 AIRFLOW SCHEMATIC			
DFTM	TH	3/21/2018	CHKD BP
DRAWING NUMBER		SHEET 1 OF 1	
		ACD-19747	
		A	

## 2.0 Models & Features

The model NU-581, LabGard™ ES HD Class II, Type A2 Laminar Flow Biosafety Cabinet is manufactured in three sizes: 4ft. (1.2m), 5 ft. (1.5m), and 6 ft. (1.8m).



REV	ECO	DESCRIPTION	DATE	DFTM	CHKD
B	13713	CORRECTED TITLE BLOCK TITLE	4/16/2018	TH	DSH

REV	ECO	DESCRIPTION	DATE	DFTM	CHKD
B	13713	CORRECTED TITLE BLOCK TITLE	4/16/2018	TH	DSH

4/6

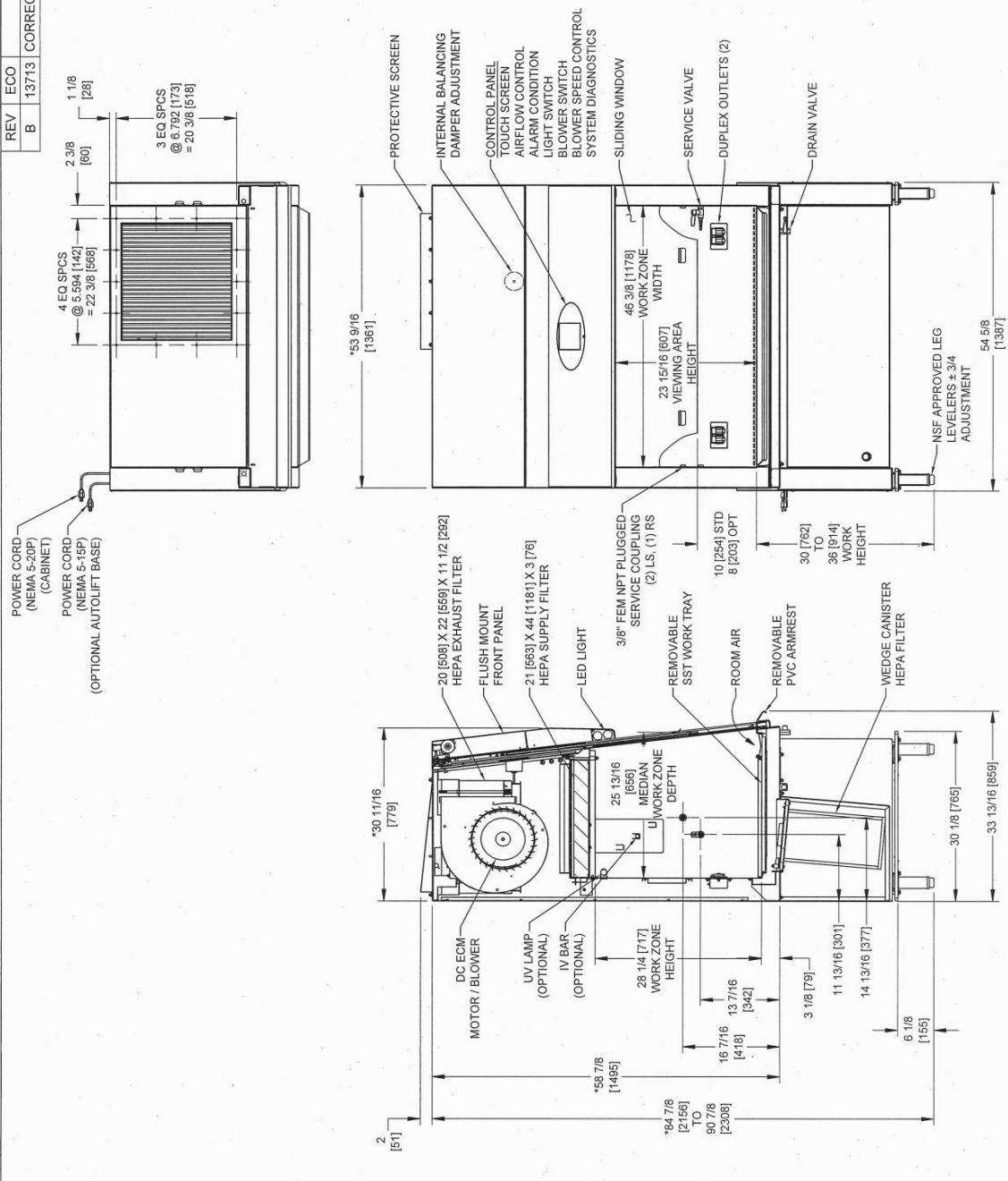

\*OVERALL DIMENSIONAL TOLERANCE ±1/4 [6.35]  
ALL OTHER DIMENSIONS ±1/8 [3.17]

		<b>ORIGINAL</b>	
TITLE		NU-581-400	
CLASS II TYPE A2		BIO. SAFETY CABINET	
DFTM	DATE	CHKD	SHEET
TH	3/21/2018	BP	1 OF 1
DRAWING NUMBER		BCD-19748	
		B	

REV	ECO	DESCRIPTION	DATE	DFTM	CHKD
B	13713	CORRECTED TITLE BLOCK TITLE	4/16/2018	TH	DSH

REV	ECO	DESCRIPTION	DATE	DFTM	CHKD
B	13713	CORRECTED TITLE BLOCK TITLE	4/16/2018	TH	DSH

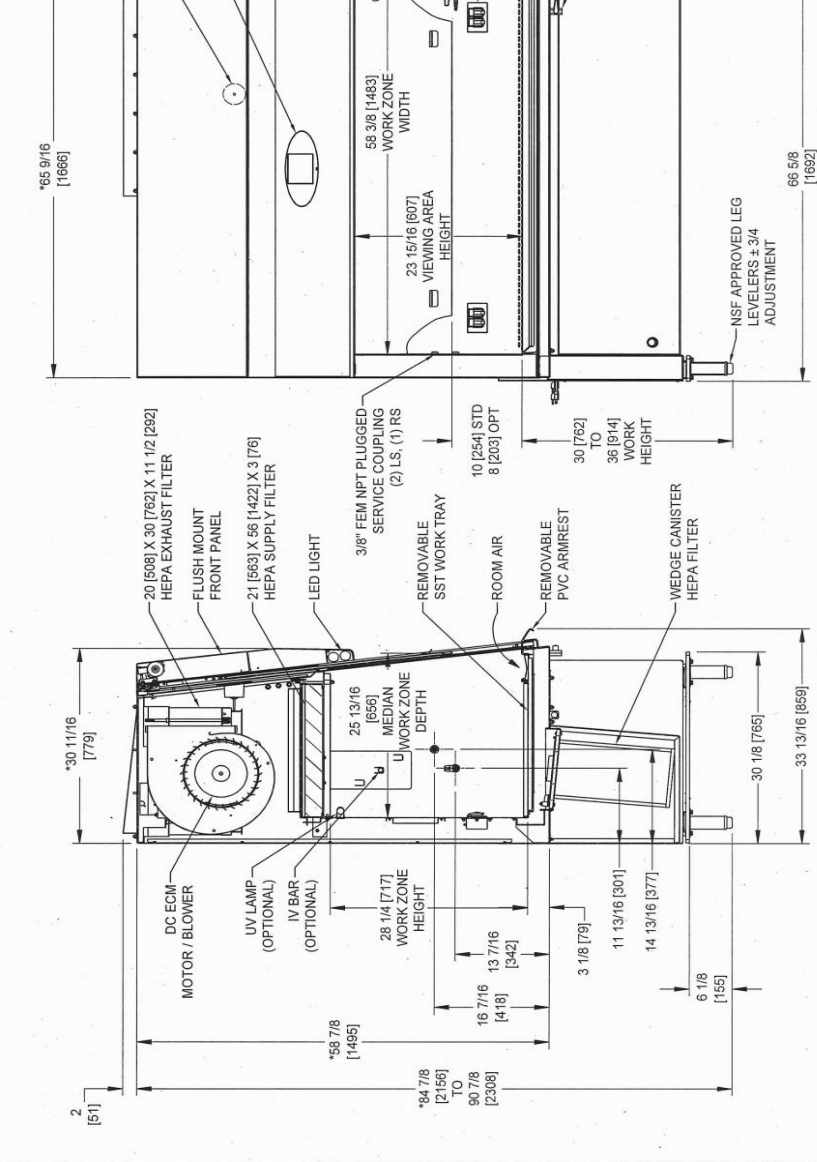
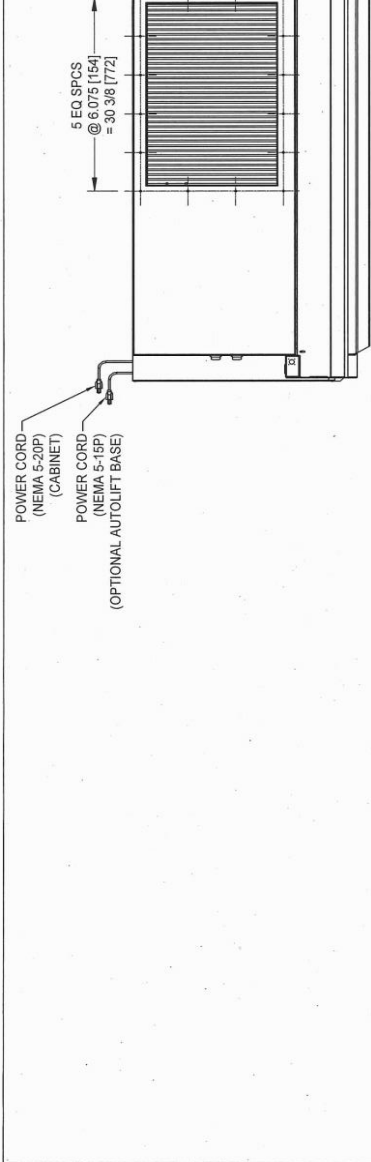

\*OVERALL DIMENSIONAL TOLERANCE ±1/4 [6.35]  
ALL OTHER DIMENSIONS ±1/8 [3.17]

		ORIGINAL	
		TITLE NU-581-500 CLASS II, TYPE A2 BIO SAFETY CABINET	DATE 3/21/2018
DFTM TH	DATE 3/21/2018	CHKD SHEET 1 OF 1	BP
DRAWING NUMBER	BCD-19749		

REV	ECO	DESCRIPTION	DATE	DFTM	CHKD
B	13713	CORRECTED TITLE BLOCK TITLE	4/16/2018	TH	DSH

REV	ECO	DESCRIPTION	DATE	DFTM	CHKD
B	13713	CORRECTED TITLE BLOCK TITLE	4/16/2018	TH	DSH

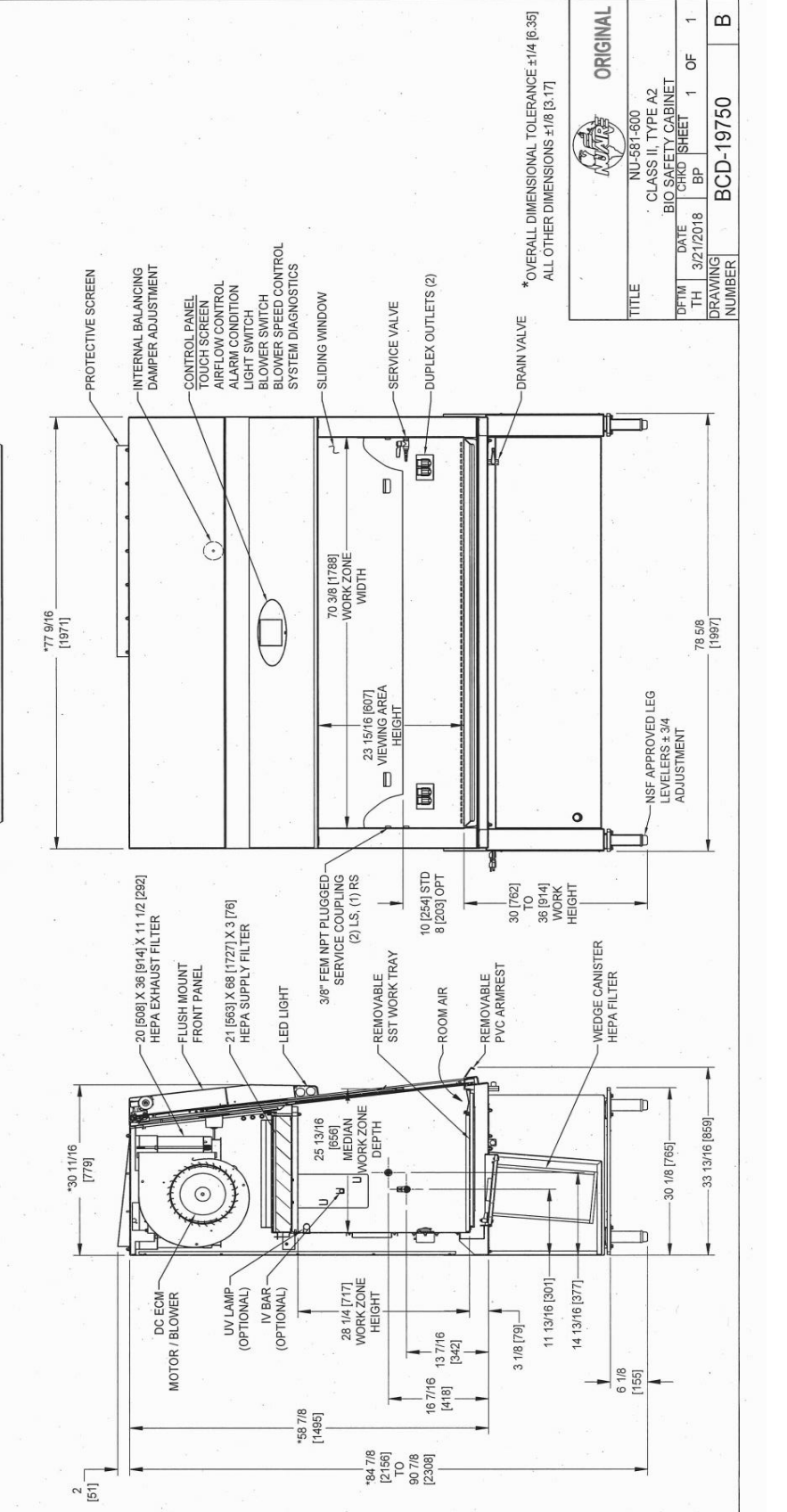
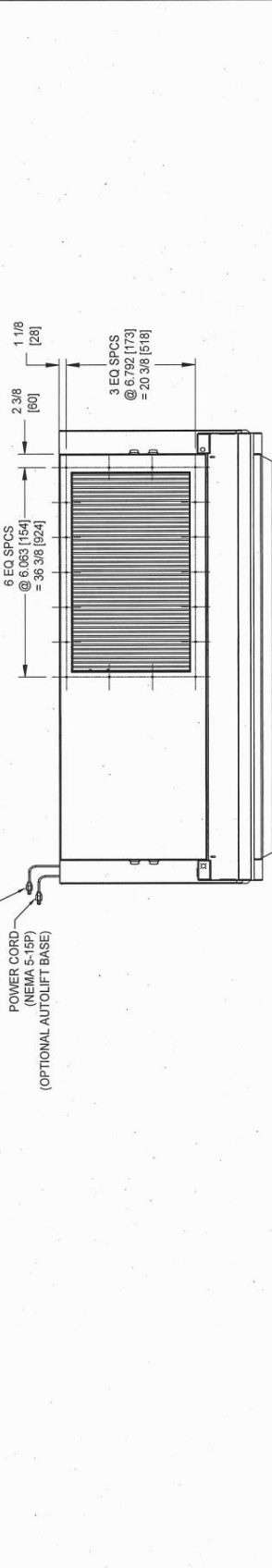

		ORIGINAL	
		TITLE NU-581-600 CLASS II, TYPE A2 BIO SAFETY CABINET	DFTM TH DATE 3/21/2018
DRAWING NUMBER BCD-19750		SHEET 1 OF 1	BP

\*OVERALL DIMENSIONAL TOLERANCE ±1/4 [6.35]  
ALL OTHER DIMENSIONS ±1/8 [3.17]

### **3.0 Warranty**

Details regarding product warranties can be found in the published warranty data separate from this manual and included within the data packet sent with the unit.

### **4.0 Shipments**

NuAire takes every reasonable precaution to assure that your LabGard™ ES HD cabinet arrives without damage. Motor carriers are carefully selected and shipping cartons have been specially designed to insure your purchase. However, damage can occur in any shipment and the following outlines the steps you should take on receipt of a NuAire LabGard™ ES HD cabinet to be sure that if damage has occurred, the proper claims and actions are taken immediately.

#### **4.1 Damaged Shipments**

- 4.1.1** Terms are factory, unless stated otherwise. Therefore, it is important to check each shipment before acceptance.
- 4.1.2** If there is visible damage, the material can be accepted after the driver makes a notation on the consignee's copy of the freight bill. Then an inspection must be made to verify the claim against the carrier. This inspection is the basis of your filing the claim against the carrier.
- 4.1.3** If concealed damage is found, it is absolutely necessary to NOTIFY THE FREIGHT AGENT AT ONCE, and request an inspection. Without this inspection, the transportation company may not accept a claim for loss or damage. If the carrier will not perform the inspection, an affidavit must be prepared stating that he was contacted on a certain date and that he failed to comply with the request. This along with other papers in the customer's possession will support the claim.

## 5.0 Installation Instructions

### 5.1 Location

Within the laboratory, pharmacy, etc., the ideal location of the Biosafety cabinet is away from personnel traffic lanes, air vents (in or out), doors and/or any other source of disruptive air currents.

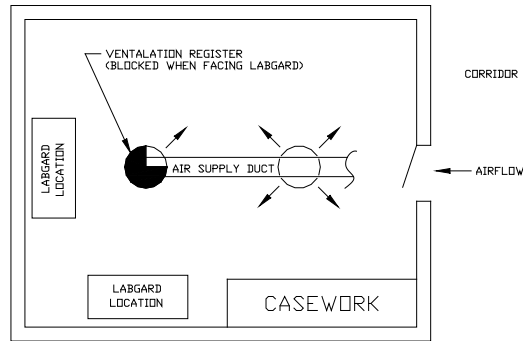

**SUGGESTED CABINET LOCATION IN LABORATORY**

THE EXHAUST FILTER AREA IS ESPECIALLY SUSCEPTIBLE TO DISRUPTIVE AIR CURRENTS FROM AIR VENTS. The Electronic Airflow Control System's exhaust sensor is located just above the exhaust HEPA filter and if disruptive air currents are present, the exhaust sensor could be influenced by them, and indicate disruptive readings on the front panel display.

If drafts or other disruptive air currents exceed the inflow velocity of the cabinet through the access opening, the *potential* exists for contaminated air to exit or enter the work zone area of the cabinet. It depends on the severity of the air current.

**REMEMBER: A BIOSAFETY CABINET IS NO SUBSTITUTE FOR GOOD LABORATORY TECHNIQUE.**

Where space permits, a clear 6" (152mm) area should be permitted on each side of the cabinet for maintenance purposes. The electrical outlet into which the cabinet is connected should be readily accessible for maintenance purposes. **Do not position the cabinet to prevent access to the power cord.** The power cord plug serves as the disconnect and should remain readily accessible. If the outlet is inaccessible, such as a conduit (hardwired) connection, then an appropriate warning label should be applied near the cabinets on/off switch to indicate the circuit breaker on the power distribution panel should be used. A MINIMUM CLEARANCE OF 6" (152MM) IS REQUIRED FROM THE TOP OF THE CABINET TO THE CEILING FOR PROPER VENTILATION OF THE EXHAUST EFFLUX.

If this cabinet is used in a pharmacy application, per OSHA, NIOSH and ASHP **it is strongly recommended that the cabinet be exhausted to the outside.** In addition, if this cabinet is used in microbiological application with minute quantities of volatile toxic chemicals and tracer amounts of radionuclides, **Per CDC/NIH and NSF it is strongly recommended that the cabinet be exhausted to the outside.** NuAire offers a canopy type of exhaust transition, which will capture the exhaust efflux from the cabinet.

Canopy, Thimble or Air Gap Exhaust Transitions (with and without integral fan)

 **NOTE: THE EXHAUST SYSTEM SHOULD BE FITTED WITH A BACKDRAFT DAMPER TO PREVENT REVERSING OR AIRFLOW IN THE SYSTEM.**

**NuAire strongly recommends a canopy or thimble exhaust for most applications.** See separate instruction sheets for a discussion of exhaust transitions and installation requirements

## 5.2 Set-Up Instructions

Remove outer shipping protection (carton or crating). The cabinet is fastened to the base skid and it is usually the best procedure to leave the skid in place until the cabinet is located in its approximate position to facilitate ease in handling. It can then be removed from the skid by removing the banding, bolts and screws holding the cabinet to the skid. The leg levelers may then be attached. The cabinet should be pushed off the skid attaching the castors on each corner as the castor base plates over hang the skid. **IT IS RECOMMENDED THAT NO LESS THAN TWO PEOPLE PERFORM THE SKID REMOVAL AND CASTOR ATTACHMENT PROCESS.** It may be necessary to remove the Control Center in order to gain passage through a doorway. It can easily be removed by following the instructions on drawing BCD-11817.



It is recommended that no less than two people are present using a lifting system for placement of the cabinet onto the base stand. It is not recommended to manually lift the cabinet onto the base stand.

### 5.2.1 Manual Cabinet Height Adjustment (BCD-13923)

To manually adjust the height of the cabinet, remove the outside cover panels on the cabinet base. While supporting the cabinet base loosen the bolts on the telescoping legs and remove them allowing the leg assembly to freely move. Place at desired height and reattach bolts and cover panel. Only adjust one side at a time.

### 5.2.2 Leveling

Using a level placed on the work tray, adjust the leg levelers, first, end to end, then, front to back. The NSF approved leg levelers provide a  $\pm 3/4"$  (20mm) adjustment.

### 5.2.3 Gas Service

NuAire doesn't recommend the use of natural gas within the BSC, but if gas service is determined to be necessary for the application, appropriate safety measures must take place.

All NuAire BSC's have precautionary warning labels that say the following:

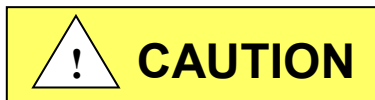

**Use of explosive or flammable substances in this cabinet should be evaluated by your appropriate safety personnel.**

Once the determination has been made by the appropriate safety personnel, the application of natural gas must be performed in accordance to national, state and local codes. **IT IS ALSO STRONGLY RECOMMENDED THAT AN EMERGENCY GAS SHUTOFF VALVE BE PLACED JUST OUTSIDE THE BSC ON THE GAS SUPPLY LINE.**

The NuAire BSC's meet the safety requirements of UL and CSA for Laboratory Equipment. To comply with these safety requirements, NuAire uses only certified gas valves. In addition, if external piping is required, only black pipe is used for this application.

As previously stated NuAire doesn't recommend the use of natural gas within the BSC and **ASSUMES NO RESPONSIBILITY FOR ITS USE. USE AT YOUR OWN RISK.** The Bunsen burner flame within the BSC not only contributes to heat build-up; is also disrupts the laminar air stream, which must be maintained for maximum efficiency. **IF THE PROCEDURE DEMANDS USE OF A FLAME, A BUNSEN BURNER WITH ON DEMAND IGNITION IS STRONGLY RECOMMENDED. DO NOT USE CONSTANT FLAME GAS BURNERS.** During use, the Bunsen burner should be placed to the rear of the workspace where resulting air turbulence will have a minimal effect.

### 5.2.4 Plumbing Services

Service ball valves with the type of service specified by the removable button on the handle are located in the work zone. The service ball valves are not recommended for pressure over 75 p.s.i. (5.2 BAR). Reducing valves should be installed external to the cabinet if necessary. Service ball valves should never be used for flammable gasses or oxygen service. A special needle valve for oxygen service or certified valve is required and available upon request.

External connection is to 3/8 inch (10mm) NPT coupling in the inner sidewalls. Connection to plant utilities should be made with proper materials for the individual service and according to national and/or local codes. Observe all labels pertaining to the type of service and operating pressure.

### 5.2.5 Electrical Services

The NU-581 series Biosafety Cabinets may be "hardwired" (optional) or plugged into an outlet with protective earthing connection with the standard power cord. The cabinet requires 115 VAC, 60 Hz, single phase (current rating varies per cabinet size, reference Electrical/Environmental Requirements). It is recommended that power to the cabinet whether hardwired or plug connected be on its own branch circuit, protected with a circuit breaker at the distribution panel near the cabinet. **A surge protector is strongly recommended** if you are experiencing power related faults.

**NOTE:** THIS CABINET CONTAINS ELECTRONIC BALLASTS FOR THE FLUORSCENT LIGHTING. ELECTRONIC BALLASTS OPERATE WITH HIGH INRUSH CURRENT. IT IS NOT RECOMMENDED TO USE THIS PRODUCT WITH GROUND FAULT CIRCUIT INTERRUPTERS (GFCI'S) BECAUSE THE BALLASTS MAY CAUSE THE GFCI TO TRIP.

### 5.2.6 Final Assembly

**NOTE:** Remove the protective cardboard cover over the exhaust HEPA filter.

Attach the exhaust sensor shroud over the exhaust sensor. The shroud should be placed as close as possible to the exhaust HEPA filter without coming in contact. The sensor gasket should be tightly against the sensor shroud to prevent sneak airflow paths. The exterior surface and viewing glass are easily cleaned with any mild household detergent cleaner using a soft cloth. Harsh chemicals, solvent-type cleaners and abrasive cleaners should not be used.

Do not attempt to clean the HEPA filter media. Cabinet interior walls or work surface are easily cleaned with any mild household detergent cleaner using a soft cloth. Turn the cabinet on and let it operate for 60 minutes before using it as a LFBSC.

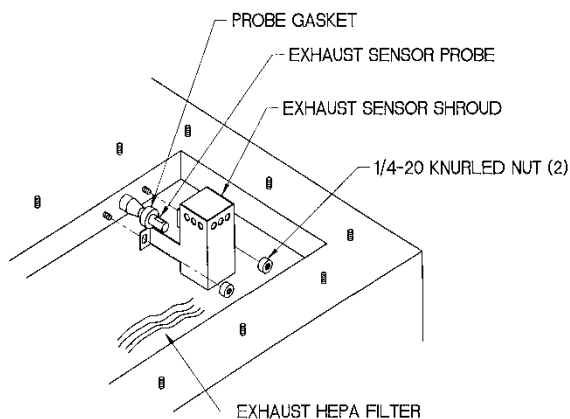

EXHAUST SENSOR SHROUD INSTALLATION

### 5.3 Testing Methods and Equipment

After installation and prior to use, NuAire recommends that the cabinet be tested or commissioned to factory standards. As part of testing, the certifier should go through the following initial checklist to assure all aspects of the BSC installation are complete and ready for testing.

- Review product installation
  - Exhaust connection, if present
  - Damper valve installed correctly with label toward front, if present
  - BSC basestand level
- Verify airflow sensor shroud is in place
  - Downflow
  - Exhaust flow
- Verify configuration type selection for specific model \* (see section 7.6.2.1)
- Verify setpoints and alarm limits for specific model \* (see section 7.6.2.1)
- Perform BSC installation tests
  - At a minimum, the following tests should be performed, but not limited to:
    - Primary and secondary HEPA filter leak tests
    - Downflow velocity test with high/low alarm limits
    - Inflow velocity test with high/low alarm limits
    - Airflow smoke patterns

The testing methods and equipment required are specified in the general maintenance section and on the factory inspection report included with this manual (see insert in back cover).

 **NOTE: IT IS RECOMMENDED THAT THESE TESTS BE PERFORMED BY A QUALIFIED TECHNICIAN, WHO IS FAMILIAR WITH THE METHODS AND PROCEDURES FOR TESTING BIOSAFETY CABINETS**

 **NOTE: AFTER THE INITIAL INSTALLATION TEST, NUAIRE RECOMMENDS THAT THE CABINET BE RETESTED AT A MINIMUM ON AN ANNUAL BASIS AND AFTER EVERY FILTER CHANGE OR MAINTENANCE ACTION OR ANY TIME THE OPERATOR FEELS IT IS NECESSARY.**

Note that the LabGard™ ES HD cabinets, filters and seals provide premium performance; Quality Control in both design and manufacturing assure superior reliability. However, protection to both product and operator is so vital that installation testing to the performance requirements should be accomplished as stated to ensure Biosafety established by the factory standards.



**LabGard™ ES HD Energy Saver Class II Type, A2 Laminar Flow Biosafety Cabinet**

Models NU-581-400/500/600

Catalog Number	Catalog Number		
	NU-581-400 Nominal 4 foot (1.2m)	NU-581-500 Nominal 5 foot (1.5m)	NU-581-600 Nominal 6 foot (1.8m)
Performance Specifications 1. Personal Protection 2. Product Protection	NSF/ANSI 49	NSF/ANSI 49	NSF/ANSI 49
NSF/ANSI 49	Class II, Type A2	Class II, Type A2	Class II, Type A2
Style of Cabinet	Console	Console	Console
Cabinet Construction Pressure Tight Design	All welded stainless steel 16GA, Type 304 14GA HRS Base	All welded stainless steel 16GA, Type 304 14GA HRS Base	All welded stainless steel 16GA, Type 304 14GA HRS Base
Diffuser for Air Supply (Metal)	Non-flammable	Non-flammable	Non-flammable
HEPA Filter Seal Type: Supply Filter-99.99% Eff. on 0.3 microns Exhaust Filter-99.99% Eff. on 0.3 microns Wedge Prefilter-99.97% Eff. on 0.3 microns	HEPEX Seal Neoprene Neoprene	HEPEX Seal Neoprene Neoprene	HEPEX Seal Neoprene Neoprene
Fumigation : per NIH/NSF Procedures	Yes	Yes	Yes
Standard Services: Service Coupling (3/8 inch NPT) Gas Valve/Service Coupling (3/8inch NPT) Duplex Outlet	One, Right Sidewall One, Right Sidewall Two, Backwall	One, Right Sidewall One, Right Sidewall Two, Backwall	One, Right Sidewall One, Right Sidewall Two, Backwall
Optional Services: Gas Cocks 3/8" NPT Ultraviolet Light	Up to 3 ea. Sidewall One, Backwall	Up to 3 ea. Sidewall One, Backwall	Up to 3 ea. Sidewall One, Backwall
Cabinet Size Inches (mm): Height (Fully Assembled) Min / Max Height (Minimum for Transport) Width Depth (with Control Center) And Armrest Removed	86 7/8 (2207) / 92 7/8 (2359) 79 3/8 (2016) 54 7/8 (1394) 33 (838)	86 7/8 (2207) / 92 7/8 (2359) 79 3/8 (2016) 66 7/8 (1699) 33 (838)	86 7/8 (2207) / 92 7/8 (2359) 79 3/8 (2016) 78 7/8 (2003) 33 (838)
Work Access Opening Inches (mm): Standard Opening Height/Optional Standard Inflow Velocity	10 (254) / 8 (203) 105 FPM (.53 m/s)	10 (254) / 8 (203) 105 FPM (.53 m/s)	10 (254) / 8 (203) 105 FPM (.53 m/s)
Work Zone Inches (mm): Height Width Depth measured at 10 inches (254mm) window height	28 1/2 (724) 46 3/8 (1178) 26 (660)	28 1/2 (724) 58 3/8 (1483) 26 (660)	28 1/2 (724) 70 3/8 (1788) 26 (660)
Viewing Window Inches (mm): Standard is safety plate sliding glass	Fully closed to 18 (457) open	Fully closed to 18 (457) open	Fully closed to 18 (457) open
Required Exhaust CFM/CMH Standard/Optional: Canopy Variable Flow Thimble (NU-911) Canopy Fixed Flow Thimble (NU-907)	10(254) / 8(203) opening CFM (CMH) 363-588 (617-1000) / 295-520 (502-884) 426 (724) / 359 (610)	10(254) / 8(203) opening CFM (CMH) 451-676 (766-1149) / 365-590 (621-1003) 531 (902) / 445 (756)	10(254) / 8(203) opening CFM (CMH) 538-763 (915-1297) / 436-661 (741-1124) 634 (1071) / 552 (904)
Plant Duct Static Pressure Eng./Metric	0.05-0.1"/1.27-2.54mm H2O	0.05-0.1"/1.27-2.54mm H2O	0.05-0.1"/1.27-2.54mm H2O
Heat Rejected, BTU, Per Hour (non-vented) (vented)	2669 157	2983 198	3140 198
Electrical: Volts, AC 60 Hz +Amps: Blower/Lights (10/8 openings) Amps: Duplex Rated Amps: 12 ft. Power Cord (one)	U.L./U.L.-C Listed 115 6.0 / 5.8 3 14 12 GA - 3 Wire, 20A	U.L./U.L.-C Listed 115 6.4 / 6.2 3 14 12 GA-3 Wire, 20A	U.L./U.L.-C Listed 115 6.6 / 6.4 3 14 12 GA-3 Wire, 20A
Crated Shipping Weight:*** Net Weight	750 lbs. /340 kg. 700 lbs. /318 kg.	840 lbs. /381 kg. 790 lbs. /358 kg.	930 lbs. /422 kg. 880 lbs. /399 kg.

\*\*\*Crated shipping weight does not include weight for accessories or options

+ Based on cabinet with new filters running at 115VAC.

## 6.0 Operating the NU-581

### 6.1 Biosafety Cabinet Control

#### 6.1.1 Overview

The Biosafety Cabinet Control (BSCC) system is designed to service the control requirements of the NU-581 Biosafety Cabinet. The control system is a self-contained microprocessor driven module that will perform the following functions:

- Easy user interface via **TOUCHLINK** LCD
- Control blower DC ECM Motor via solid-state DC Motor Controller
- Monitor, display and control downflow, via digital dual thermistor airflow sensor
- Monitor and display exhaust flow (inflow) via digital dual thermistor airflow sensor
- Alarm setpoints, high/low for error conditions (downflow and exhaust flow)
- Date/Clock display and timer function
- Control lights via solid state switch
- Control outlets via solid state switch
- Complete diagnostic functions

The NU-581 BSCC system offers the latest dual microprocessor design technology for improved cabinet performance and safety. The control system uses a digital dual thermistor airflow sensor in the downflow stream to monitor and control airflow to setpoints. The control system automatically compensates for filter loading, voltage variances and other environmental effects. A second digital dual thermistor airflow sensor in the exhaust airstream monitors for inflow velocity. Both downflow and inflow are displayed on the **TOUCHLINK** LCD screen. The control system also monitors the sliding window position with a micro switch for both window height and window closed positions.

The control system through the use of the front panel controls the on/off function of the fluorescent and ultraviolet lights (optional), outlets and blower. The control system also allows contact closure outputs for interaction with HVAC systems to optimize environmental performance.

User interface to the BSCC system is accomplished via the **TOUCHLINK** LCD. Basic use of the BSC is accomplished via the icons located along the top of the screen as shown below. Touch an icon to turn on/off functions as indicated. Each icon will illuminate with color to indicate when the function is turned on. The menu icon will always prompt a menu screen to display. Selecting a menu item will continue the prompts until the desired parameter is achieved. To return to the main menu, press the MENU icon repeatedly to reverse out of the parameter menus.

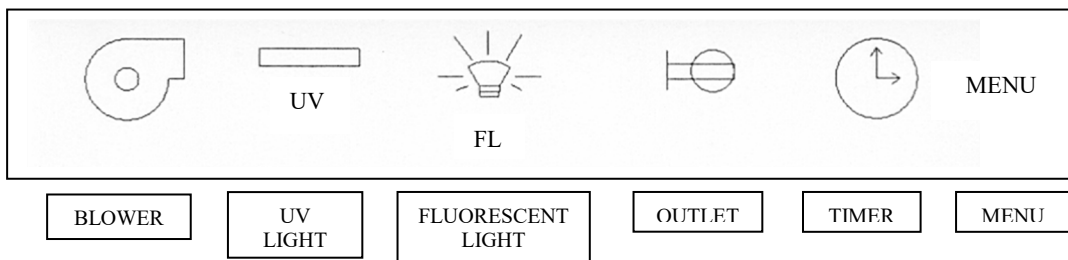

### 6.1.2 Standby Mode

When the BSC is not in use, the **TOUCHLINK** LCD screen will display a large NuAire logo, the icons along the top and the time and date at the bottom right as shown below. Any of the function icons, except the blower, that initiates Run Mode, may be turned on and off in standby mode. The timer and menu icons may also be accessed for additional user menus. The **TOUCHLINK** LCD does have a screen saver function built in for extended LCD life. The default screen saver time is 60 minutes. This means after 60 minutes when the blower is not on, the **TOUCHLINK** LCD will go dark. To bring back the **TOUCHLINK** LCD, just touch the screen and the screen saver will reset. To change the screen saver time, access SCREEN SETUP through the menu icon.

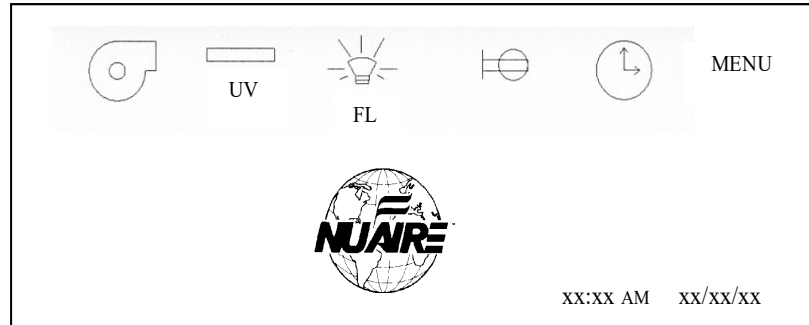

### 6.1.3 Run Mode

Anytime the blower icon is selected the Run Mode screen will appear. The Run Mode screen will display a BSC profile and initiate and display the countdown of a 150 second warm-up period. During the warm-up period the aseptic cleaning process may begin. If the sliding window is raised an audible and visual alarm will occur, but may be silenced by pressing the alarm silence icon that appears. Airflow readings will not be displayed during warm-up period.

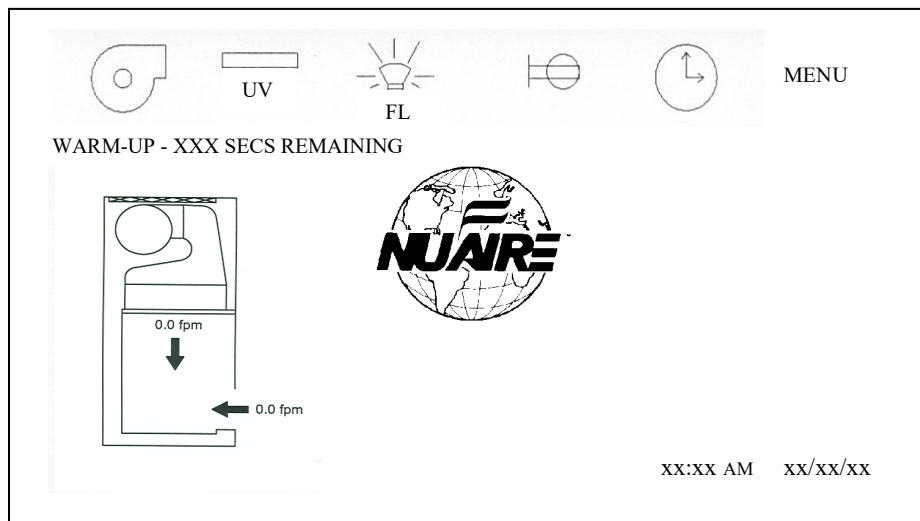

Once the warm-up period is complete, airflow readings and all system functions will operate and be displayed.

#### 6.1.4 Night Setback / Nite Care Mode

The NU-581 may be optionally configured to allow the DC ECM motor to continue to run at a lower rate with the sliding window closed allowing the workzone interior to be continually HEPA filtered. If the night setback mode is configured, the blower icon must be on and the window closed for it to be activated. In addition, the fluorescent light will be disabled. If the sliding window is then opened the cabinet will resume normal airflow setpoints in run mode.

#### 6.1.5 Standby/Run Mode Alarms

If present, standby/run mode alarms will be both visual and audible, the Red LED oval under the LCD display will turn on, and the LCD screen will also display a description of the alarm in place of the NuAire Logo along with alarm silence icon. Depending upon the alarm type, the BSC profile will also indicate in red the alarm present. Audible alarms can be silenced or will produce an alarm tone for 30 seconds, then into a ring back cycle of once every 10 seconds. Pressing the alarm silence icon will silence the audible alarm for 15 minutes, then into a ring back cycle at of once every 10 seconds.

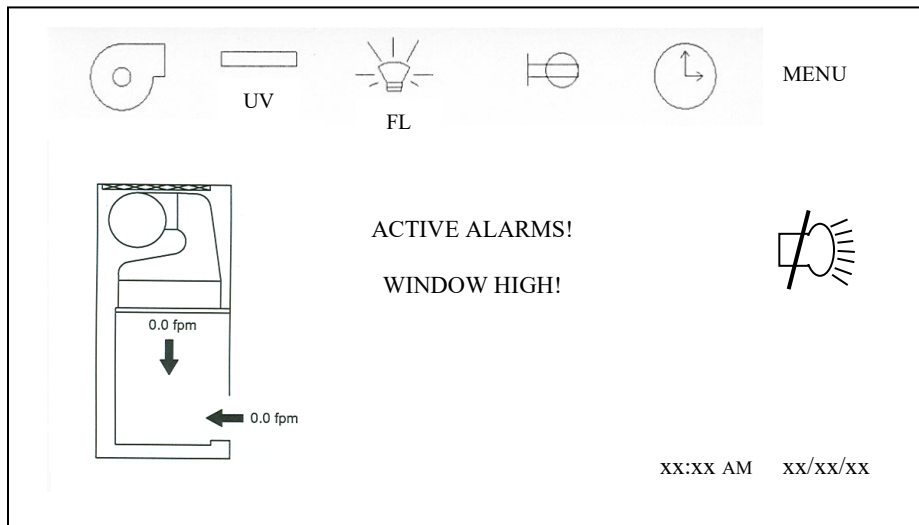

#### Alarm Types

- Window High - window is raised above its nominal height
- Downflow High Limit- downflow is above the high alarm setpoint
- Downflow Low Limit - downflow is below the low alarm setpoint
- Inflow High Limit - inflow is above the high alarm setpoint
- Inflow Low Limit - inflow is below the low alarm setpoint

### 6.1.6 Timer Icons

The timer icon, when pressed will provide a list of time functions available for use. Below is a description of each timer function.

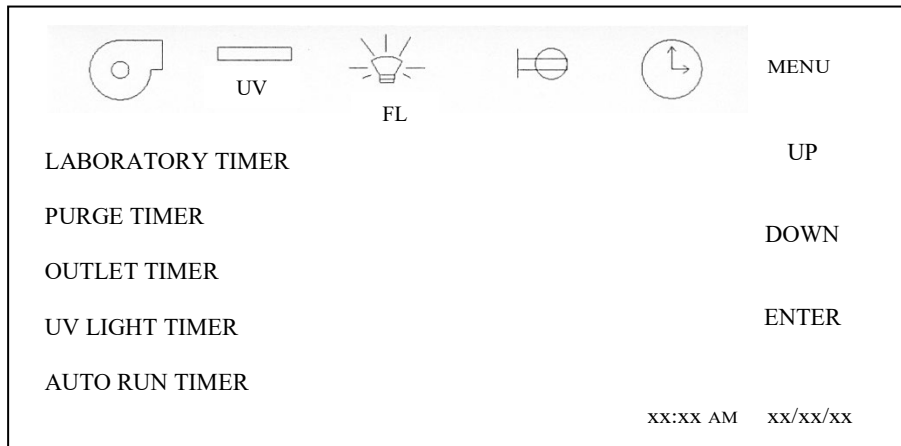

#### Timer Functions

- Laboratory Timer - A general purpose timer that when set to a value, will countdown and alarm upon timer expiration.

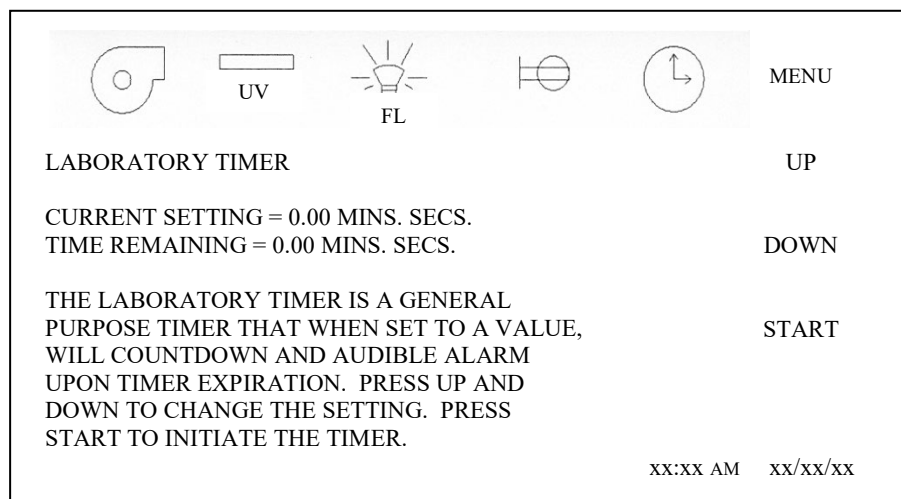

- Purge Timer - This timer controls how long the blower will run to purge the cabinet after the blower icon has been pressed to turn off the blower.

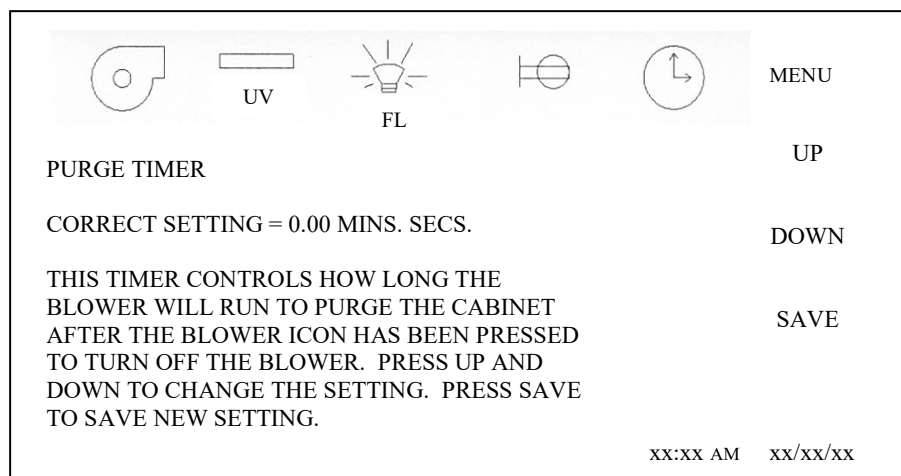

- Outlet Timer - This timer controls how long the outlet remains on after the outlet icon has been pressed to turn on the outlet. If timer is zero, the outlet will stay on until turned off.

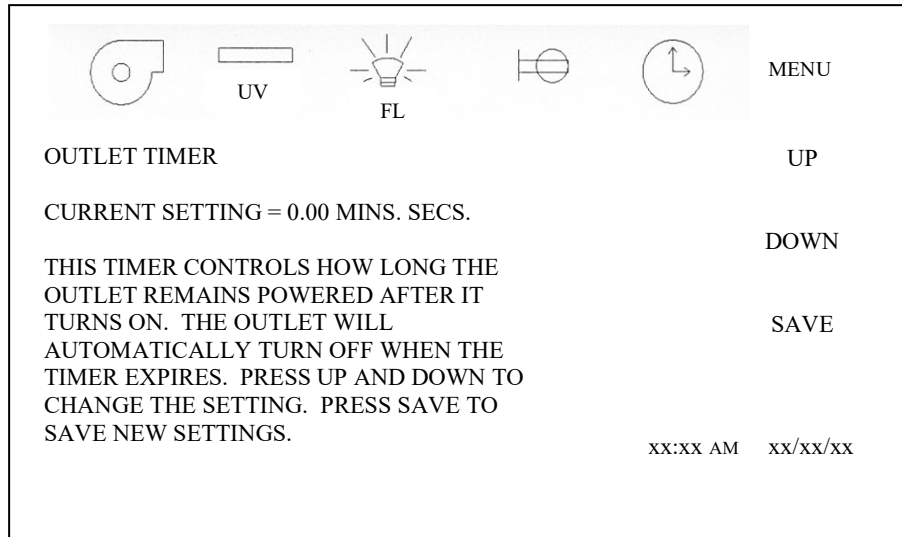

- UV Light Timer - This timer controls how long the UV light will remain on after the UV light icon has been pressed to turn on the UV light. If timer is zero, UV light will stay on until turned off.

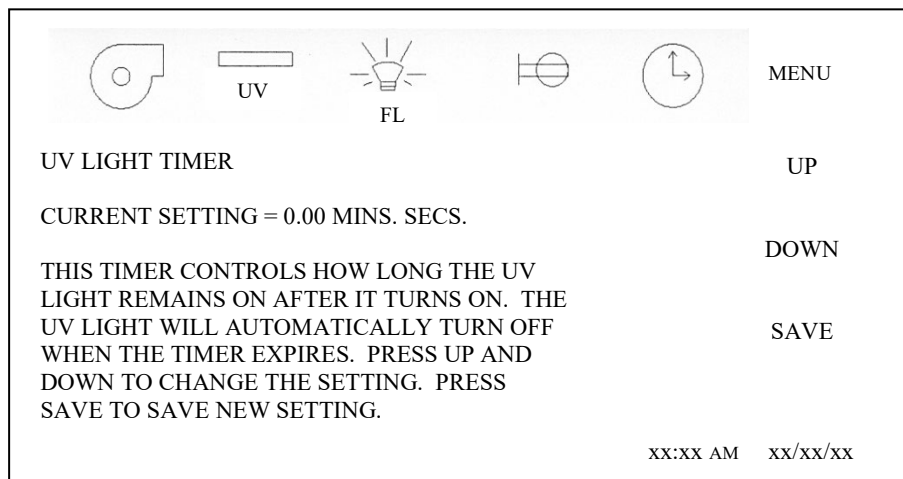

- Auto Run Timer - This timer provides the ability to program on a daily basis the start and stop time of the cabinet. To start and stop the cabinets menus that both the blower and fluorescent lights will automatically turn on and off together on a programmed schedule.

Once into the auto timer menu, select the desired day for the auto timer to function. If multiple days are desired, each day will be required to be set individually.

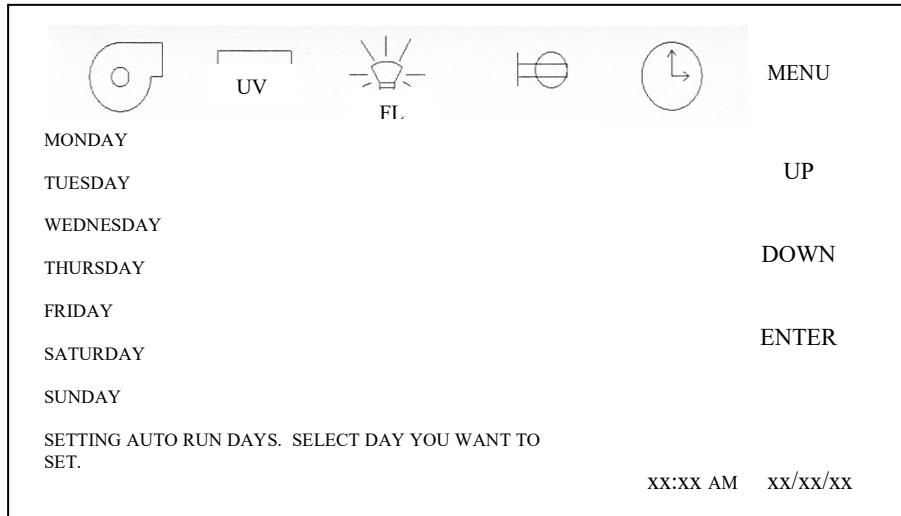

Once into the selected day, press UP or DOWN to enter the on/off times. Use the >> and << to select hours or minutes. Press SWITCH to toggle between auto time on and auto time off. Press SAVE after each time entry. Press DIS to disable auto timer for the day being reviewed. Repeat auto timer function for each day as desired.

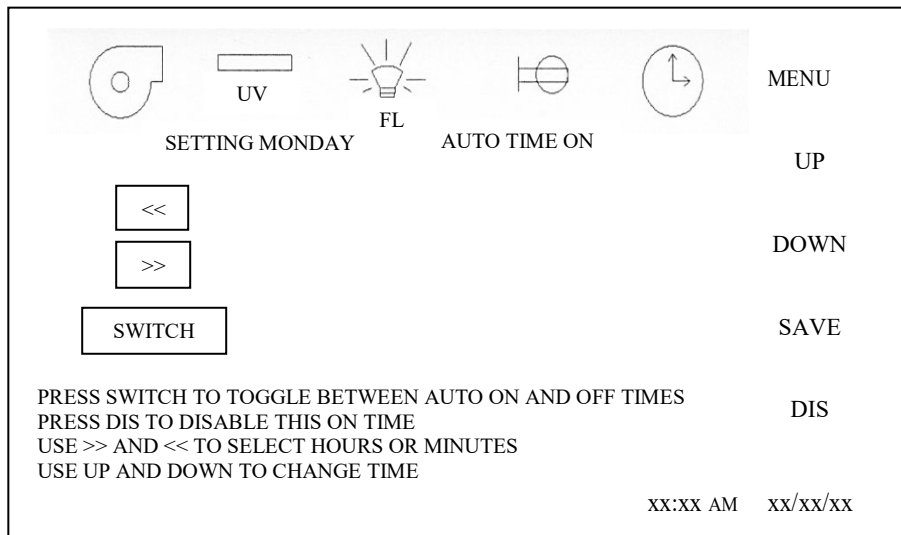

### 6.1.7 Menu Icon

The menu icon, when pressed will provide a list of menu items for various BSCC functions.

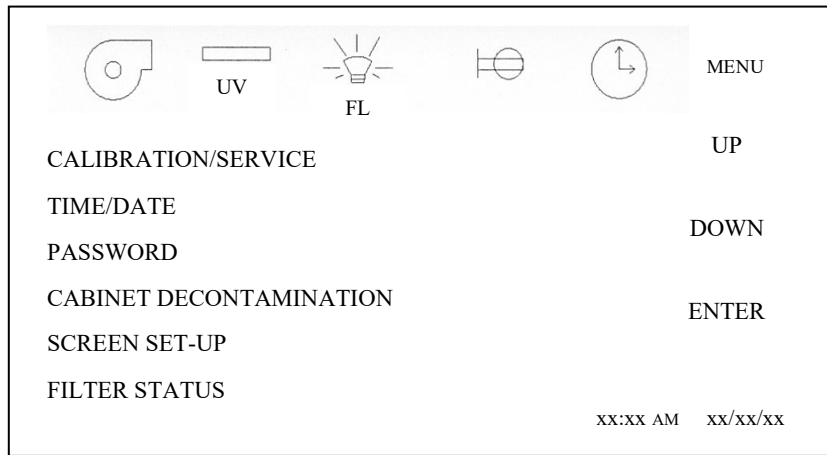

#### Menu Items

- Calibration/Service - A password protected area used by certification or service personnel to set up and calibrate the cabinet for certification or commissioning.
- Time/Date - This menu item provides the ability to set the time and date displayed on the LCD screen. Time displayed is real time and will not automatically adjust for day light saving time.

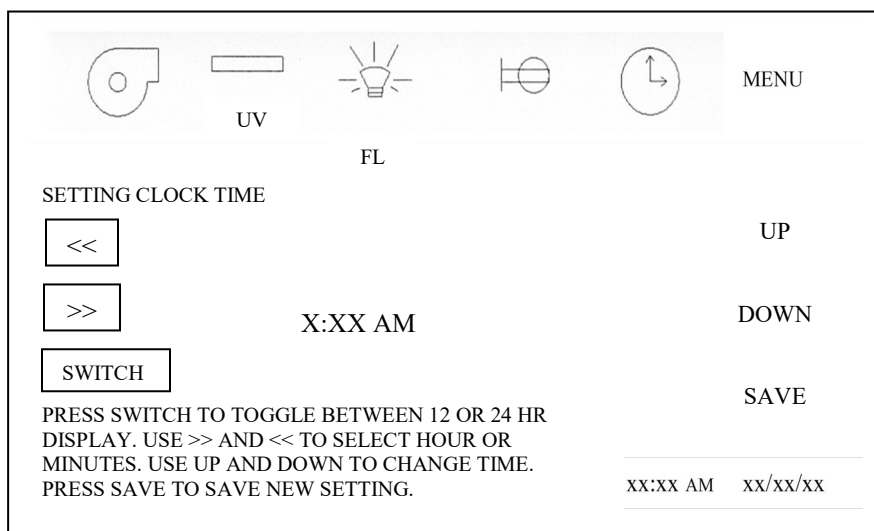
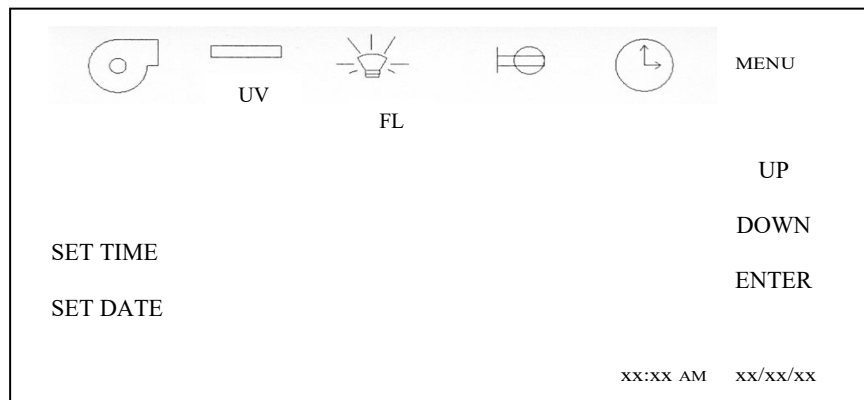



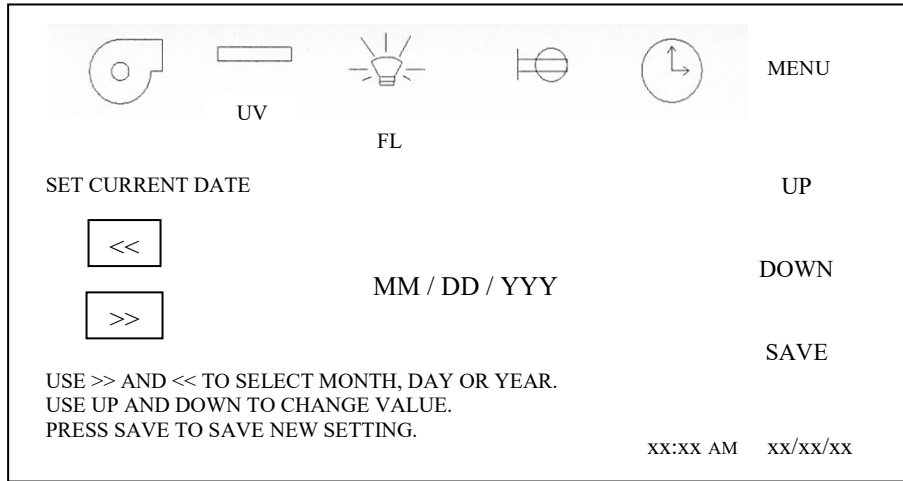

- Password - This menu item provides the ability to change the user password from the default value of 1234.

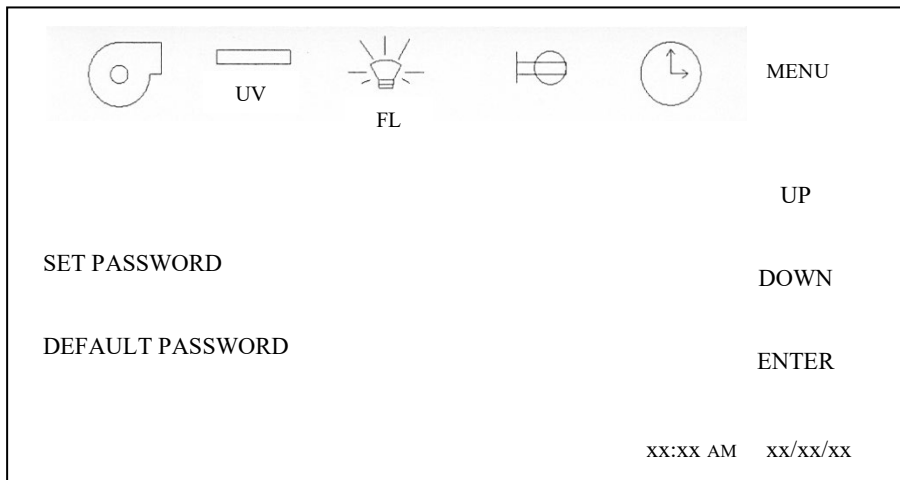

- Set Password

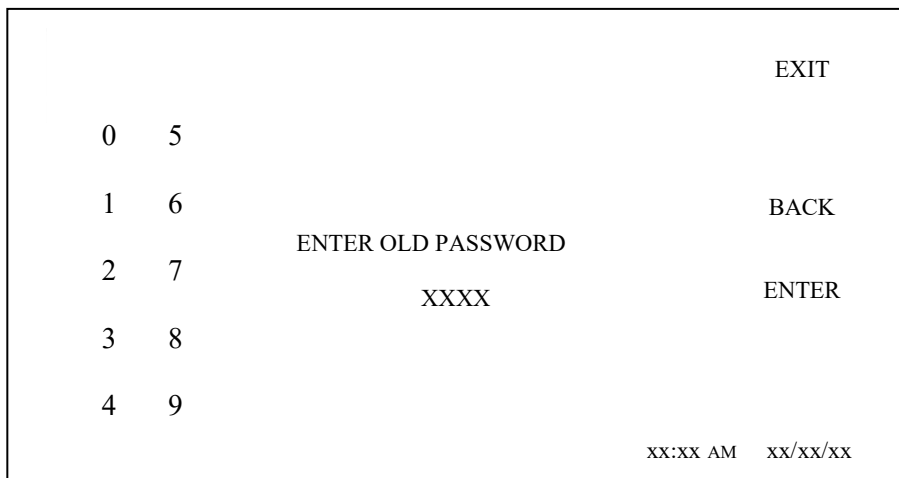

- Default Password

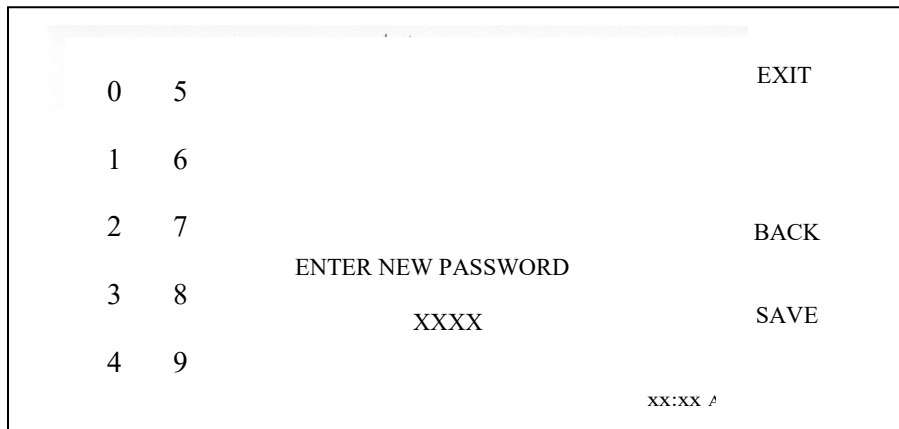
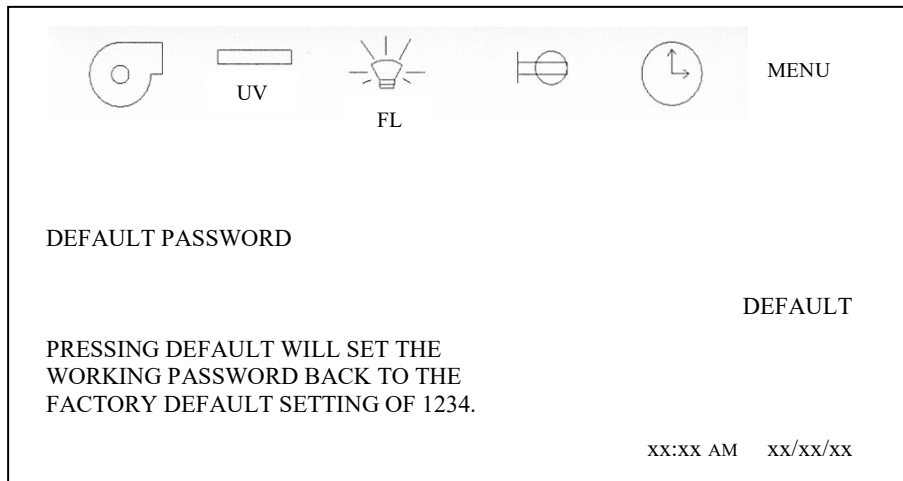

- Decon Cycle - This menu item provides the ability to perform an automated or manual decon procedure. (See decontamination section for instructions).
- Screen Set-Up - This menu item provides the ability to alter LCD screen display background contrast and audible touch screen tone.

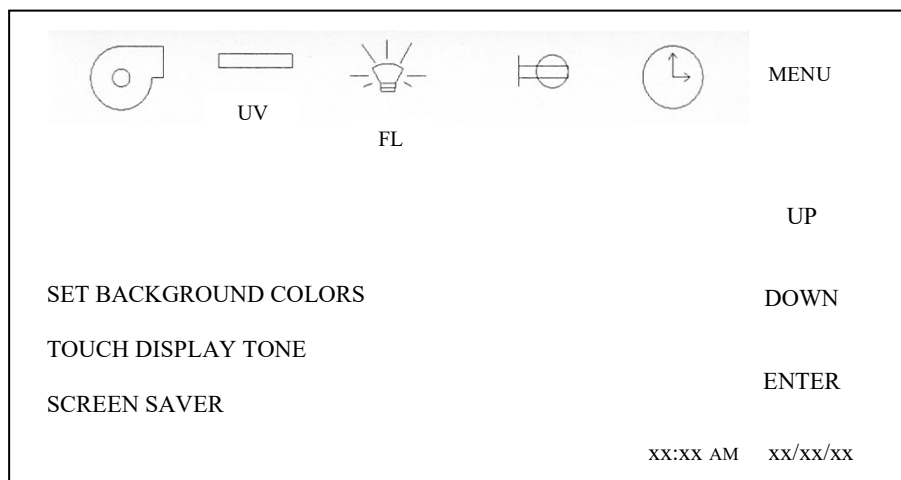

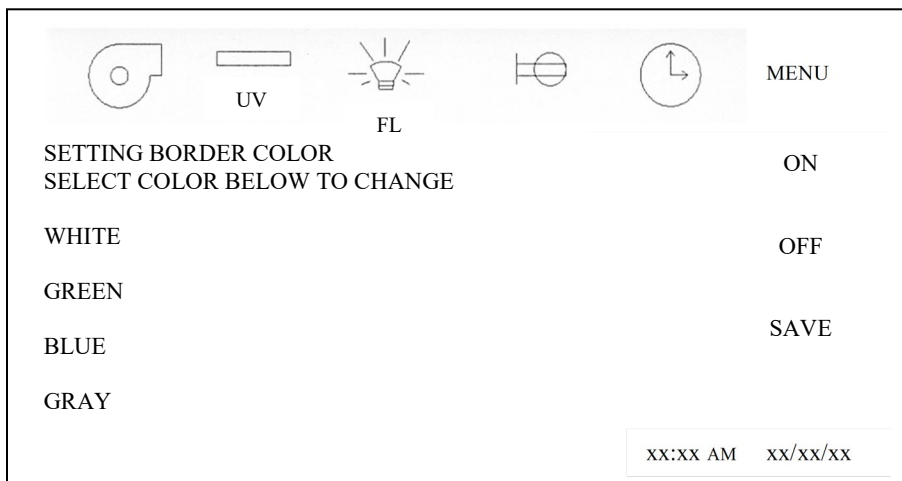
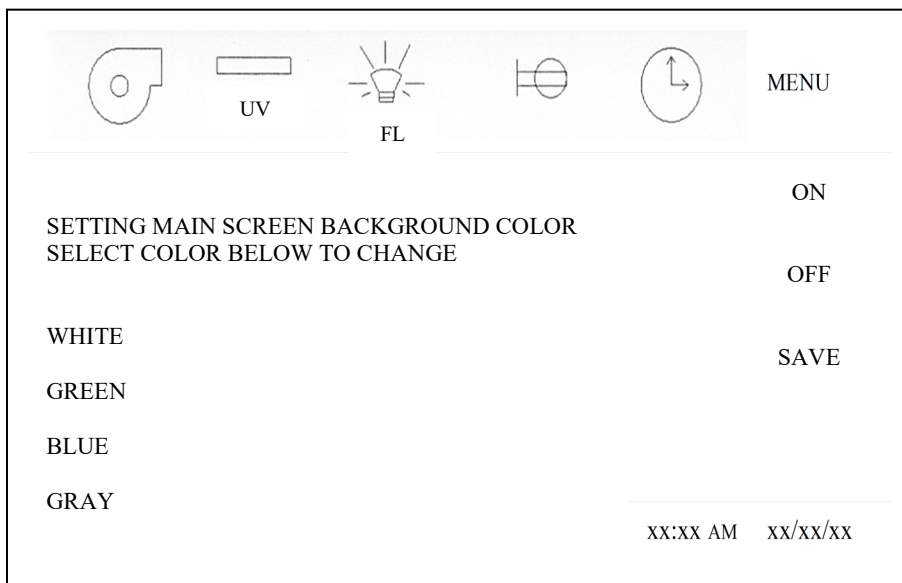
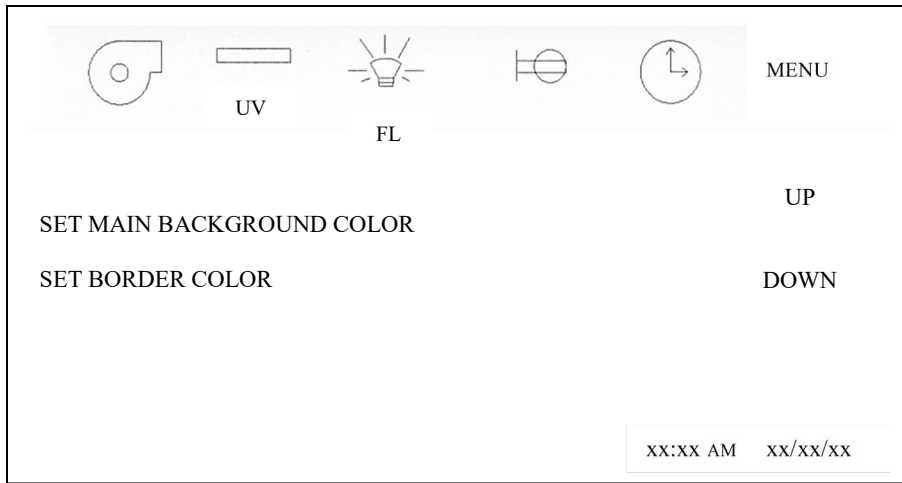

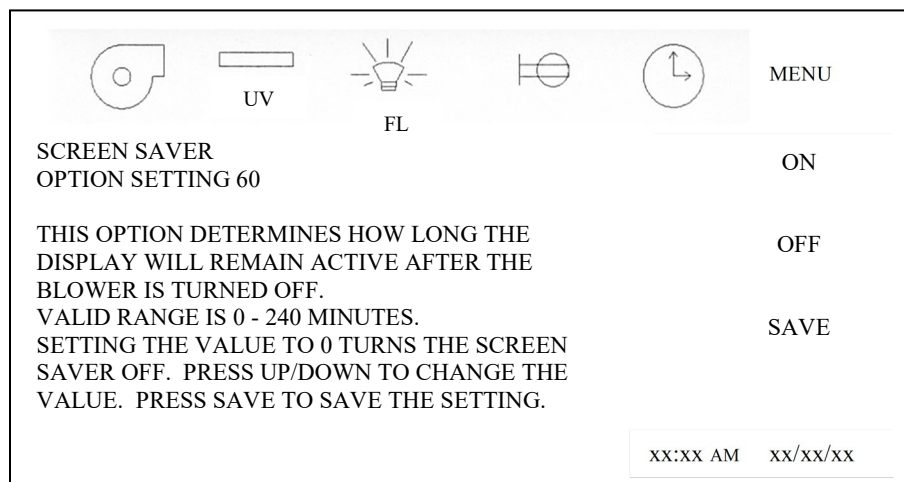
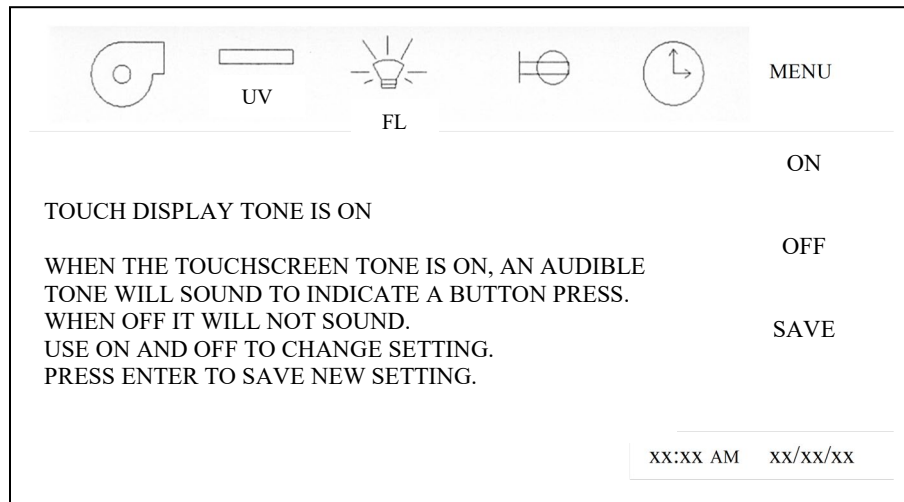

- Filter Status - This menu item provides the status of available filter life.



### 6.1.8 Power Window Option

The power window option, if purchased, is factory installed and the display will indicate window up and down icons just above the time and date. The power window function uses a 24 Vdc motor and internal feedback encoder to determine position. The power window also incorporates a safety auto-reverse feature to eliminate any pinch hazard.

Operating the power window is performed by pressing either the UP or DOWN window icon. The travel is determined by the length of time the icon is pressed. A short press and release will make the window move a short distance. A long press and release will make the window move to the next standard operating point of either closed, nominal work access height of 8 inches (203mm) or full open. The power window is required to be lowered during the decontamination process for sealing purposes after the armrest is removed.

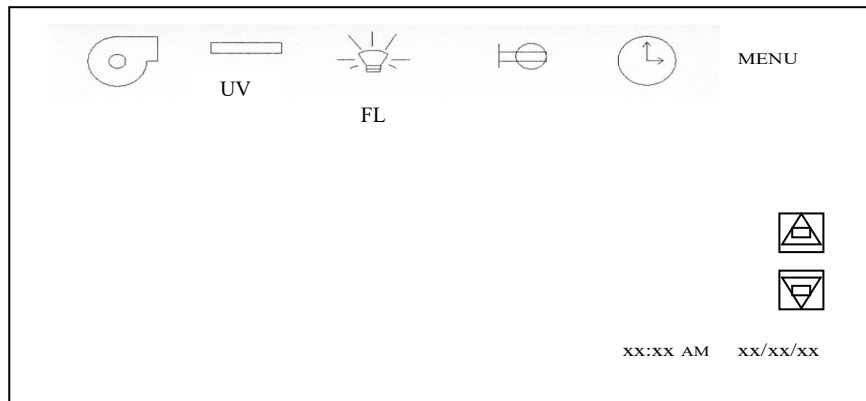

### 6.2 Operating Guidelines

The intent herein is to present general operational guidelines that will aid in the use of the Laminar Flow Biosafety Cabinet (LFBSC) to control airborne contaminants of low to moderate risk as stated in Technical Report Number FPS 56500000001, prepared by Dow Chemical U.S.A. for the National Cancer Institute, May 1, 1972.

Procedure protocols defined in terms of the barrier or control concepts unique to LFBSC must be developed in order to obtain a maximum potential for safety and protection. The pre-planning necessary to develop these protocols is based on several fundamental considerations, each of which will contribute to optimum benefits from the equipment:

- a. Know you "Safe Work Area"
- b. Minimize disruption of "air curtain"
- c. Minimize room activity
- d. Utilize unidirectional airflow
- e. Employ aseptic techniques

### 6.2.1 Know your "Safe Working Area"

The LFBSC safe working area is basically the worktray or depressed area. All work should be performed on or above the worktray. The area on or above the front grill is a non-safe working area.

-  **NOTE:** It is important to maintain an air gap on both sides of the worktray before fastening in place. The work tray as being part of the cabinet system has been designed to load up to 100 lbs. (45.4 kg) of work materials. Any additional loading should be evaluated by appropriate safety personnel.

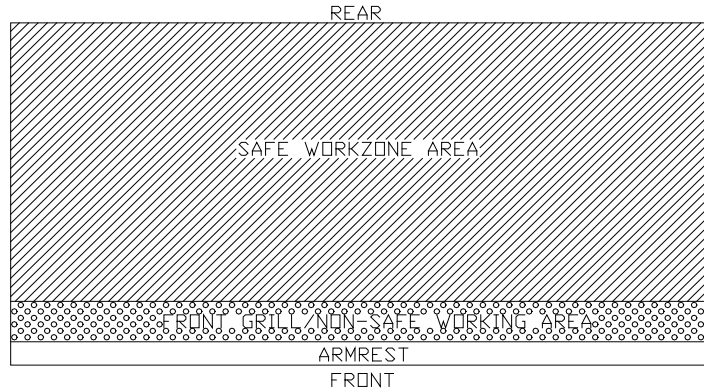

### 6.2.2 Minimize Penetration of "Air Curtain"

The minimum number of items necessary should be placed into the cabinet to prevent overloading, but the work should also be planned to minimize the number of times an operator's hands and arms must enter and leave the air curtain at the open face. The ideal situation is to have everything needed for the complete procedure placed in the hood before starting, so that nothing need pass in or out through the air barrier at the face until the procedure is completed. This is especially important in working with moderate risk agents.

Unnecessary raising of the hands inside the cabinet above the level of the work opening should be avoided. This presents an inclined plane from hands to elbows along which the downflow of air may run to, and possibly out, the open face.

-  **Note:** When working with agents of lower risk, it is not as important for all materials to be placed in the cabinet before starting, or for the procedure to be completely finished before materials are removed. Also, the time period for cabinet may be continued over a more extended period during which entries and withdrawals from the cabinet may be made.

### 6.2.3 Minimize Room Activity

Activity in the room itself should be held to a minimum. Unnecessary activity may create disruptive air currents as well as interfere with the work of the operator. A person walking past the front of a cabinet can cause draft velocities up to 175 fpm (.89 m/s), which are sufficient to disrupt the air balance of the laminar flow cabinet.

### 6.2.4 Utilize Unidirectional Air Flow

The operator must keep two important facts in mind: (1) The air, as supplied to the work area through filters from the top, is contaminant free and (2) Airborne contamination generated in the work area is controlled by the unidirectional flow of parallel air streams in a top-to-bottom direction.

A solid object placed in a laminar air stream will disrupt the parallel flow and consequently, the capability of controlling lateral movement of airborne particulates. A cone of turbulence extends below the object and laminarity of the air stream is not regained until a point is reached downstream, approximately equal to three to six times the diameter of the object. Within the parameters of this cone, particles may be carried laterally by multidirectional eddy currents.

Transfer of viable materials and manipulations, which may generate aerosols, should not be performed above sterile or uninoculated materials. Items should be localized on the work surface in "clean" and "dirty" groups.

### 6.2.5 Employ Aseptic Technique

The operator must not assume an attitude of "let the cabinet do it" when performing procedures within a LFBSC. Properly balanced and properly used cabinets will do an excellent job of controlling airborne contamination and containing viable agents, but the cabinet will not eliminate contact transmission of contamination. Normal laboratory contamination control procedures and basic aseptic techniques are necessary to obtain maximum benefit from the cabinet. For example, open bottle, tube or flask mounts should be kept as parallel as possible to the downflow to minimize capture of chance particulates. This precaution is merely an extension of good aseptic technique as practiced on open bench tops. The good laboratory practices designed to minimize creation and/or release of aerosols to the environment should not be discontinued.

Items of equipment in direct contact with the etiologic agent must remain in the cabinet until enclosed or until surface-decontaminated. Trays of discard pipettes must be covered before removal from the cabinet (aluminum foil may substitute for fabricated covers).

If an accident occurs which spills or splatters suspensions of etiologic agent around the work area, all surfaces and items in the cabinet must be surface-decontaminated before being removed.

Applying a burner flame to flask and tube necks when mating surfaces of sterile assemblies is a conventional method of minimizing chance contamination. However, the efficiency of this operation is usually related to the removal of airborne contamination occurring while the item is uncovered. If the manipulation is carried out in an environment free of airborne particulates, then the need for the flaming operation is essentially removed. This is one of the additional advantages of the LFBSC - use of the gas burner is seldom necessary. The gas burner flame in one of these cabinets not only contributes significantly to the heat build-up, it also disrupts the laminar air streams which must be maintained for maximum efficiency. If the procedure demands use of a flame, **A BUNSEN BURNER WITH ON DEMAND IGNITION IS RECOMMENDED. DO NOT USE CONSTANT FLAME GAS BURNERS.** It should also be only used from the center of the work surface to the right rear where resulting air turbulence will have a minimal effect. **DO NOT USE GAS BURNER ON THE LEFT SIDE OF THE WORK SURFACE DUE TO ITS INFLUENCE ON THE ELECTRONIC AIRFLOW CONTROL SYSTEM.** If cabinet air is inadvertently turned off, the flame could damage the HEPA filters.

## 6.3 Operating Sequence

### 6.3.1 Start Up

Turn on cabinet blower and lights, check air intake and exhaust portals of the cabinet to make sure they are unobstructed. The electronic airflow control system will automatically control airflows to specified setpoints. However, upon filter loading, the cabinet may be required to be re-balanced or filters replaced. Only a qualified maintenance technician should perform cabinet balancing and filter replacement.

 **NOTE:** Some cabinets are equipped with ultraviolet (UV) lights. Good procedure includes the decontamination or wipe down of cabinet surfaces with chemical disinfectant before work commences. This practice eliminates the need for UV lights, whose primary utility in this application is inactivation of surface contamination since the filters effectively remove all airborne contaminants. UV lights, therefore, are not recommended in the LFBSC.

Allow blowers to operate for a minimum of 15 minutes before aseptic manipulations are begun in the cabinet. If the filtered air exhausted from the cabinet is discharged into the room, as in some installations, an additional advantage is obtained from purification (filtration) of the room air circulated through the equipment. Because of this characteristic contributing to the quality of the laboratory environment, some owners of LFBSC leave them in operation beyond the time of actual use.

### 6.3.2 Wipe Down

The interior surfaces of the workspace should next be disinfected (see Cleaning Procedures) by wiping them thoroughly with 70% alcohol or similar non-corrosive anti-microbial agents.

**USE OF CHLORINATED OR HALOGEN MATERIALS IN THE CABINET MAY DAMAGE STAINLESS STEEL.**

### 6.3.3 Materials & Equipment

The apparatus and materials should next be placed into the cabinet. Care must be exercised that no items be placed over the front intake grills. Materials should be arranged so that clean, dirty (used), and virus materials are well separated. Passage of contaminated materials over uninoculated cultures or clean glassware should be avoided and transfer of viable materials should be performed as deeply into the cabinet (away from open face) as possible.

### 6.3.4 Air Purge

Additional purging of the workspace without user activity should be allowed for 2-3 minutes after materials and apparatus have been placed in it. This will rid the area of all "loose" contamination that may have been introduced with the items.

### 6.3.5 Perform Work

The work can now be performed. The technician performing the work is encouraged to wear a long-sleeved gown with knit cuffs and rubber gloves. This will minimize the shedding of skin flora into the work area and concurrently protect the hands and arms from viable agent contamination. At a minimum, the hands and arms should be washed well with germicidal soap before and after work in the cabinet.

The work can now be performed. The technician performing the work is encouraged to wear a long-sleeved gown with knit cuffs and rubber gloves. This will minimize the shedding of skin flora into the work area and concurrently protect the hands and arms from viable agent contamination. At a minimum, the hands and arms should be washed well with germicidal soap before and after work in the cabinet. For the preparation of antineoplastic drugs, the following procedures summarize those contained in OSHA's guidelines to Controlling Occupational Exposure to Hazardous Drugs. The OSHA document should be thoroughly studied and reviewed prior to drug preparation in the cabinet. It may be found at this website:

[https://www.osha.gov/SLTC/hazardousdrugs/controlling\\_occx\\_hazardousdrugs.html](https://www.osha.gov/SLTC/hazardousdrugs/controlling_occx_hazardousdrugs.html)

- a. A sterile plastic-backed absorbent drape should be placed on the work surface during mixing procedures. The drape should be exchanged whenever significant spillage occurs, or at the end of each production sequence.
- b. Vials should be vented with a filter needle to eliminate internal pressure or vacuum.
- c. Before opening ampoules, care should be taken to insure that no liquid remains in the tip of the ampoule. A sterile gauze sponge should be wrapped around the neck of the ampoule while opening.
- d. Final drug measurement should be performed prior to removing the needle from the stopper of the vial.
- e. A non-splash collection vessel should be available in the LFBSC to discard excess drug solutions.

### 6.3.6 Terminal Purging & Wipe Down

Following completion of work, allow the cabinet to run for 2-3 minute period without personnel activity to purge the cabinet. A surface disinfection of the interior surfaces (see Cleaning Procedures section) should be repeated after removal of all materials, cultures, apparatus, etc. A careful check of grills and diffuser grids should be made for spilled or splashed nutrients which may support fungus growth and resulting spore liberation that contaminates the protected work environment.

### 6.3.7 Paper Catch/Prefilter

A removable paper catch is located above each prefilter under the worksurface. This area forms the return air path to the motor/blower and if the airflow is blocked it could seriously affect the performance of the cabinet. Therefore, **THE PAPER CATCH SHOULD BE CHECKED AND CLEANED NO LESS THAN ON A WEEKLY BASIS; DAILY** basis if procedures dictate the use of paper products. Any paper removed must be properly disposed of as *Contaminated Hazardous Waste*.

### 6.3.8 Shut Down

Turn off blowers and lights. Do not use cabinet as a depository for excess lab equipment during periods of non-operation. If antineoplastic agents are being prepared in the cabinet, it is recommended to let the cabinet run 24 hours per day. This lessens the possibility that contaminants may escape.



## 6.4 Ergonomics

Ergonomics, the study or accommodation of work practices is extremely important for proper cabinet usage and user health and safety. An evaluation of normal work practices should be performed with each user when working in a cabinet. Evaluation criteria should be at a minimum:

- a. Proper user posture
- b. Effective workzone layout for work practice
- c. Vision or sightlines

For each of the above evaluation criterion, several work aids may be supplied to accommodate the user.

- Ergonomic chair - A six-way articulating seat and back control for personalized adjustment to assure proper user posture. Be sure feet are resting on the floor, chair foot support or foot rest. Also be sure back is fully supported with proper chair adjustments.
- Forearm/elbow support - The cabinet is provided with a non-metallic forearm support on the work access opening. Periodic mini-breaks during work practice should be taken resting forearm to avoid stress and fatigue. Elbow rests are optional that can provide support for particular work practices, such as pipetting. Also available as an option, closed cell foam disposable forearm pads to reduce pressure points and add comfort.
- Effective workzone layout - Always prepare your work procedure to minimize reach to avoid neck and shoulder stress and fatigue. Rotating tables are optional to maximum workzone and minimize reach.
- Vision and sightline - Always prepare your work procedure to eliminate glare and bright reflections on the window. Keep your window clean and sightlines clear to your effective workzone.

## 6.5 Cleaning Procedures

### 6.5.1 General

Cleaning laboratory equipment is important in terms of both functionality and general good housekeeping. The information provided below is intended to aid the development of facility Standard Operating Procedures (SOP's) for cleaning the equipment. It is strongly recommended that all cleaning materials used be tested and verified in terms of both effectiveness and material compatibility before they are written into the cleaning SOP documentation.

- a. The airflow blower should be operating during the cleaning process to maintain sterility and/or containment during the cleaning process.
- b. Raise window to gain additional access if desired.
- c. Apply appropriate cleaning material or surface disinfectant to surfaces. Most surface disinfectants require a specific contact time depending the materials used within the work zone. **CONSULT APPROPRIATE DISINFECTANT DOCUMENTATION FOR PROPER APPLICATION AND SAFETY PRECAUTIONS.**
  - c-1. Stainless steel (type 304) has noted material compatibility concerns with Acids, Chlorides and Halogens. **IF THESE MATERIALS ARE USED AND ALLOWED TO BE LEFT ON THE STAINLESS STEEL SURFACE, OXIDATION AND DEGRADATION WILL OCCUR.** Only by re-wiping surfaces with either sterile water or 70% IPA will remove harmful materials from the stainless steel surface.

Further information is available at the following: [http://www.parrinst.com/wp-content/uploads/downloads/2011/07/Parr\\_Stainless-Steels-Corrosion-Info.pdf](http://www.parrinst.com/wp-content/uploads/downloads/2011/07/Parr_Stainless-Steels-Corrosion-Info.pdf)

NOTE: NuAire does not offer any product warranty with respect to cleaning material compatibility. **USE AT YOUR OWN RISK!** The information provided above is from raw material suppliers and known general source documents for use to develop application cleaning SOP's.

-  NOTE: When cleaning the work area for the first several times, the new metal surfaces may produce some dark discolorization on the white cleaning wipes. Repeated cleaning will continuously reduce the amount of the discolorization material on the cleaning wipes over time.

## 7.0 General Maintenance



All maintenance actions on this equipment must be performed by a qualified technician who is familiar with the proper maintenance procedures required including both certification and repair.

### 7.1 Decontamination

No maintenance should be performed on the interior of the LabGard™ ES HD cabinet (area behind access panels) unless the cabinet has been microbiologically decontaminated, is known to be biologically clean, or known to be chemically inert. Surface disinfection is performed as specified in the Cleaning Procedures section.



Hazardous Gases! Personal Protection Equipment Required.



Decontamination using hazardous gas, vapor or mist must be performed in accordance with the specifications of NSF/ANSI 49, Annex G, EN12469, Annex J or applicable national, state, province or local regulations

This procedure presents considerable risks and must be performed only by specially trained and authorized service personnel in accordance with applicable national safety regulations.

The decontaminate is generated either external or internal of the sealed cabinet. The quantity of decontaminate should follow standard or manufacturer's recommendations based on cabinet volume. The decontaminate process should follow standards or manufacturer's recommendations based on the decontaminate used.



All decontaminate materials are hazardous (chemical-liquid, gas and vapor) (Flammable – process) and are required to be handled properly. Follow all product and process documentation and labelling.

The decontamination process is started by accessing the CABINET DECONTAMINATION on the main menu.

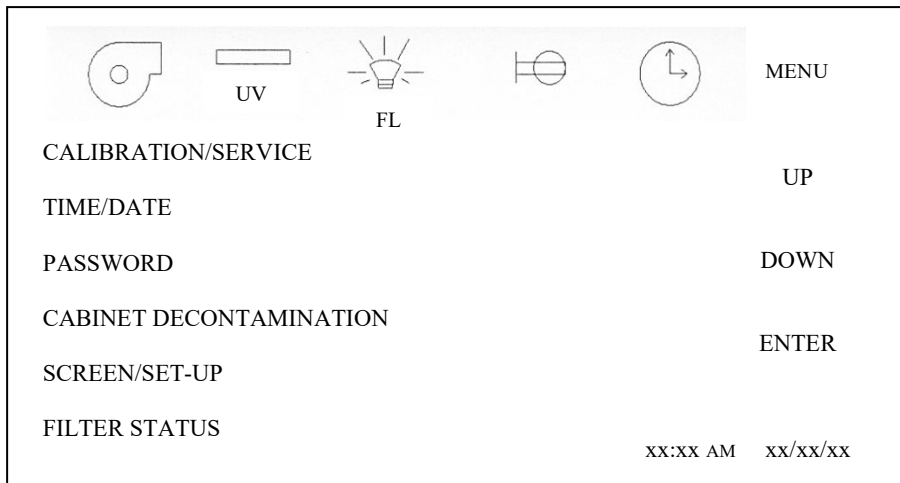

Select MANUAL DECON or AUTO DECON-H2O2/CD.

The manual decon process requires the use of NuAire accessory, Front and Top Seal Plates, (i.e. NU-985-301,401,501,601).

The Auto Decon - H2O2/CD requires the use of NuAire accessory Auto Decon Exhaust Seal Plate (i.e. NU-985-302,402,502,602). Please contact NuAire Technical Service for further assistance.

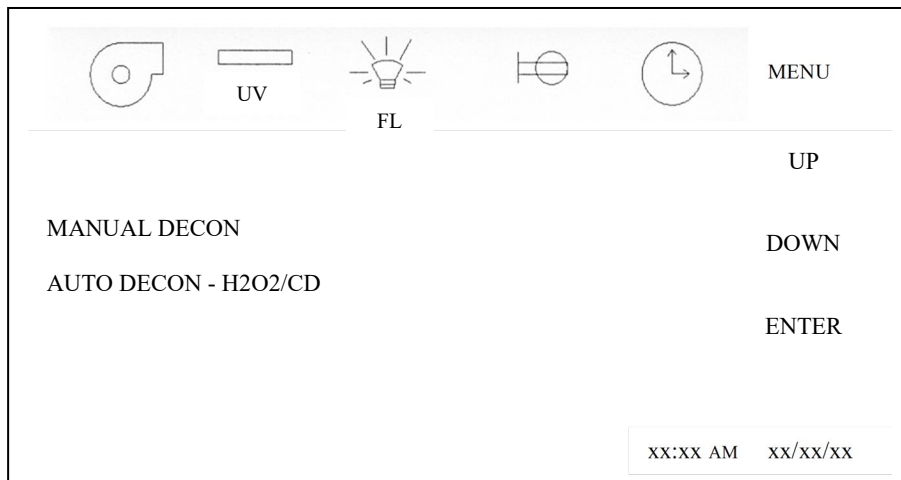

### 7.1.1 Manual Decon

1. Disconnect power to the cabinet. Remove screws at each upper side of the control center and allow the control center to rotate down, resting on the safety straps. Disconnect electrical connectors on left side. Disconnect electrical from right side. (Be sure to note the location of the supply and exhaust sensor wires before disconnecting them from the main board). Loosen safety plate next to left hinge. Remove control center by disconnecting safety straps and moving control center to the left off the slip hinges. Fold and pinch tubing to seal.
2. Remove the front decorative panel via top/front fasteners.
3. Remove window assembly (both frame and window, either being manual, sliding, or automatic) via the upper and lower fasteners (Refer to BCD-12281). At this point, the sliding window assembly can be removed.
4. Remove exhaust sensor shrouds.
5. Remove the diffuser screen and gasket around perimeter of workzone.
6. Place decontamination equipment inside the work area. Reference decontamination procedure, per EN 12469, Annex J, using the following chart to calculate chemical requirements.

Cabinet Size	400	500	600
<b>Cabinet Dimensions</b>	58-7/8 x 28 x 46-3/8 (1.50 x .711 x 1.18 m)	58-7/8 x 28 x 58-3/8 (1.50 x .711 x 1.48m)	58-7/8 x 28 x 70-3/8 (1.50 x .739 x 1.88 m)
<b>Cabinet Volume</b>	44.24 cu. ft. (1.25 cu. m)	55.69 cu. ft. (1.58 cu. m)	67.14 cu. ft. (1.90 cu. m)

 **Note:** The outlets in the work area are energized as long as the cabinet is plugged in and switched on the front panel. Unplug the cabinet before decontamination equipment is plugged into these outlets. The control centers electrical connectors may be re-attached to utilize the cabinet's interior outlets and fan during the decontamination. (See step 8)

8. Set control center on its side (with the bullet end down and the blower capacitor end up) on the left side of cabinet. Then plug in the 16-pin connector cable from the cabinet to the control center. Reconnect power to the cabinet. The outlets can then be activated. The blower can be activated from the menu decon cycle.
9. Seal front and top openings using pressure plates.
  - a. The front plate is attached using the following steps:
    - 1) Remove screws in SST header just above workzone opening.
    - 2) Place front seal plate over bottom row of studs with the plate gasket next to the work access opening and the remaining holes should line up.\*
    - 3) Fasten the plate using the fastening screws and nuts provided.
  - b. The top seal plate is attached using the following steps:
    - 1) Remove filter guard above exhaust HEPA filter.
    - 2) Remove exhaust sensor shroud via fasteners.
    - 3) Remove the (2) plugs on each side of the exhaust filter frame. As each is removed, drop plug into disinfectant.
    - 4) Place top seal plate over the studs and attach fastening nuts provided.

 **Note:** Front and top seal plates are obtained by contacting NuAire Representative or Distributor

\* Electrical service can be provided to the inside of the cabinet via the electrical bulkheads on the front pressure plate. Access to the neutralizing plate can be obtained through the liquid tight fitting on the front pressure plate.

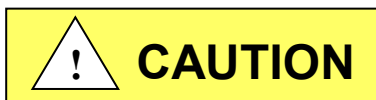

**BE SURE CABINET IS TOTALLY SEALED TO PREVENT ANY LABORATORY EXPOSURE TO DECONTAMINATION GAS.**

10. Perform decontamination procedure per NSF/ANSI, 49 Annex G.

### 7.1.2 Auto Decon

The Auto Decon process is intended to be used with any automated cabinet decontamination process (i.e. hydrogen peroxide, chlorine dioxide, etc.) The automated decon process parameters are typically set up independently of the cabinet. Inlet and outlet ports from the automated decon machine are connected to the cabinet. The cabinet control system may be set up to run simultaneously aiding the decontaminate circulation throughout the cabinet during the entire decon cycle.

To validate one decon process and associated cabinet set up procedure; NuAire utilized a Bioquell Clarus II H<sub>2</sub>O<sub>2</sub> system and performed the following process.

1. Remove armrest via fasteners.
2. Remove exhaust shroud and sensor.
3. Seal top and front openings using either heavy plastic and duct tape or seal plates.  
Seal all joints with tape as indicated on drawing BCD-16509.

 **Note:** Top and front seal plates may be obtained by contacting NuAire representative or distributor.

4. Attach inlet and outlet connections to decontamination system along with pressure and/or concentration sensor if provided.
5. Determine decontamination system cycle parameters.

Note that system parameters will change for process type, as well as cabinet model and size.

For validation purposes, a LabGard™ ES Model NU-581-600E was set using the following parameters on the Bioquell Clarus II:

Pressure Setpoint:	-10 Pa
Airflow Setpoint:	22 m <sub>3</sub> /hr
Delivery Temperature:	65°C
Conditioning Time:	10 min
Gassing Time:	40 min
Gassing Injection Rate:	6.0 g/min
Dwell Time:	90 min
Injection in Dwell:	ON
Dwell Injection Rate:	3.5 g/min
Aeration Delay:	60 min
Aeration Time:	600 min

#### Cabinet Auto Decontamination

Use the following procedure to allow the cabinet blower to automatically run at programmed intervals in sequence with the decon process equipment (i.e. Bioquell Clarus II).



REV	ECO	DESCRIPTION	DATE	DFTM	CHKD
D	13035	ADDED ALTERNATE DECON	6/23/2016	TH	DSH

2/1/16

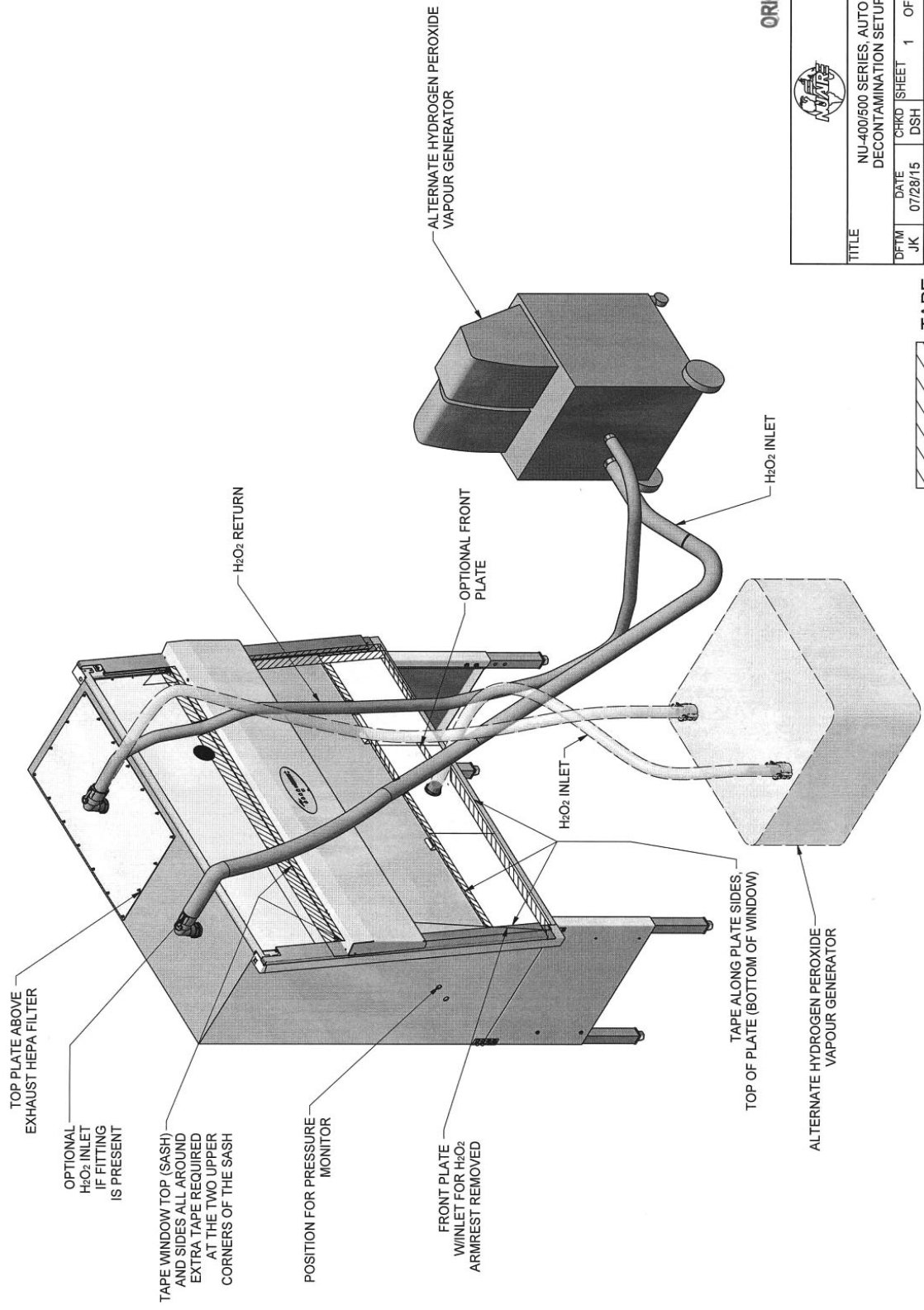

ORIGINAL

TITLE	
NU-400/500 SERIES, AUTO DECONTAMINATION SETUP	
DFTM	DATE
JK	07/28/15
CHKD	DSH
SHEET	1 OF 1
DRAWING NUMBER	BCD-16509
	D



TAPE

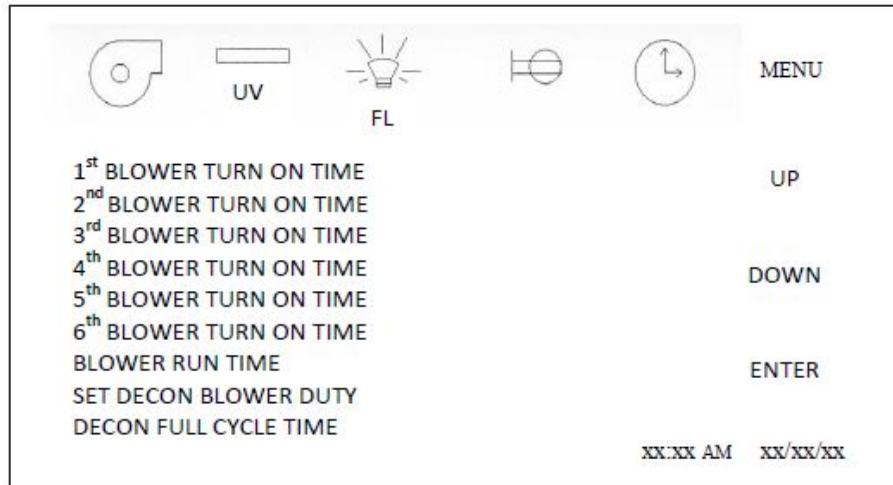

- Press 1<sup>st</sup> Blower Turn on Time

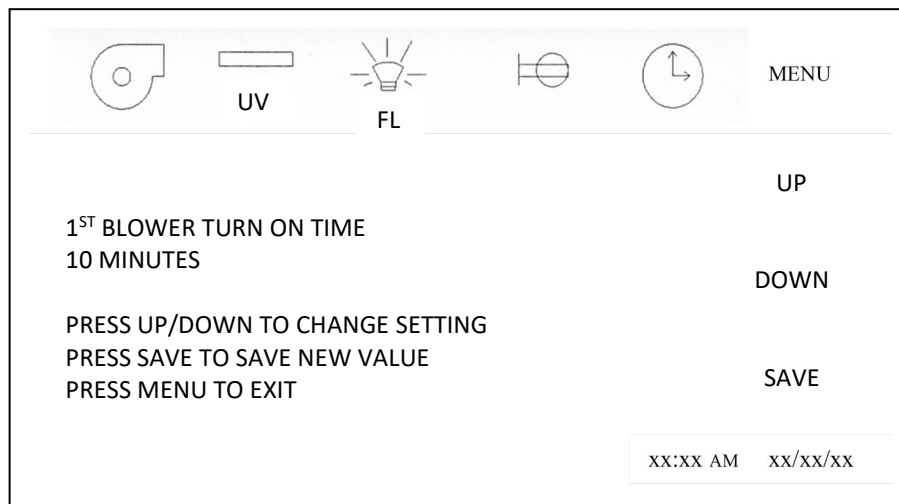

- Press up or down to adjust blower turn on time.
- Press save to save new value
- Return to menu above for 2<sup>nd</sup>, 3<sup>rd</sup>, 4<sup>th</sup>, 5<sup>th</sup> and 6<sup>th</sup> blower turn on times.

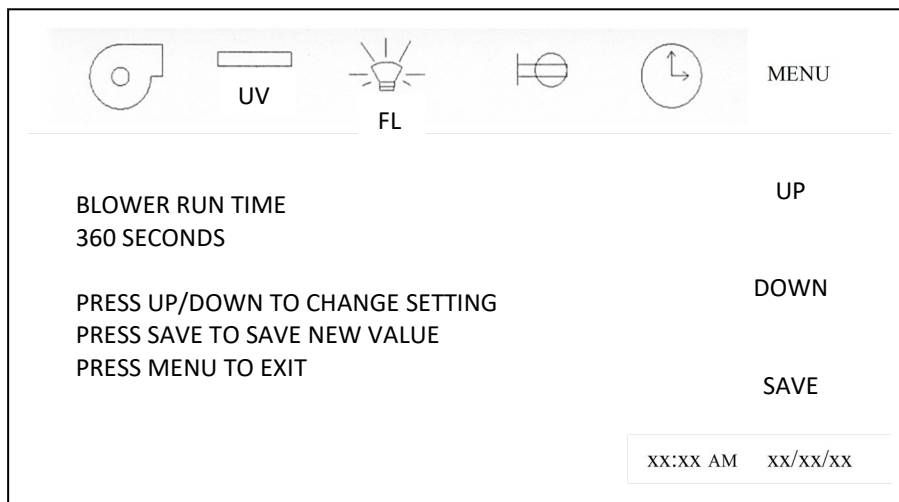

- Press up or down to adjust blower run time for each blower on cycle.
- Press save to save new value.

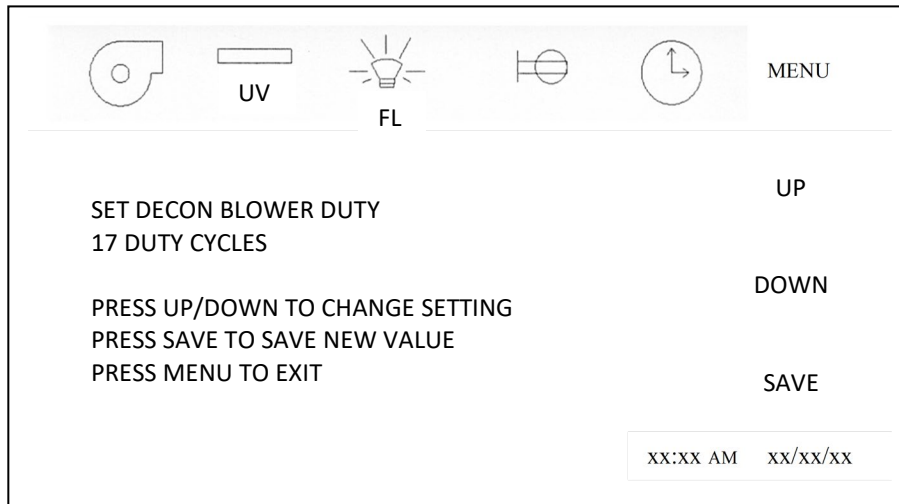

- Press up or down to adjust blower duty cycle.

**Note:** When blower is on, it is recommended that the pressure within the cabinet stay negative, so lower blower duty cycles are recommended.

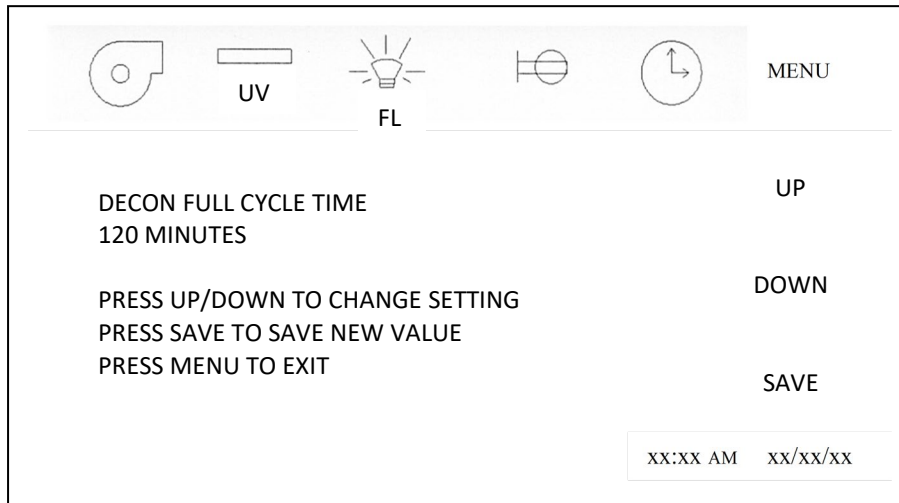

- Press up or down to adjust decon full cycle time.

**Note:** Decon cycle time for the cabinet should be identical to the decon process equipment.

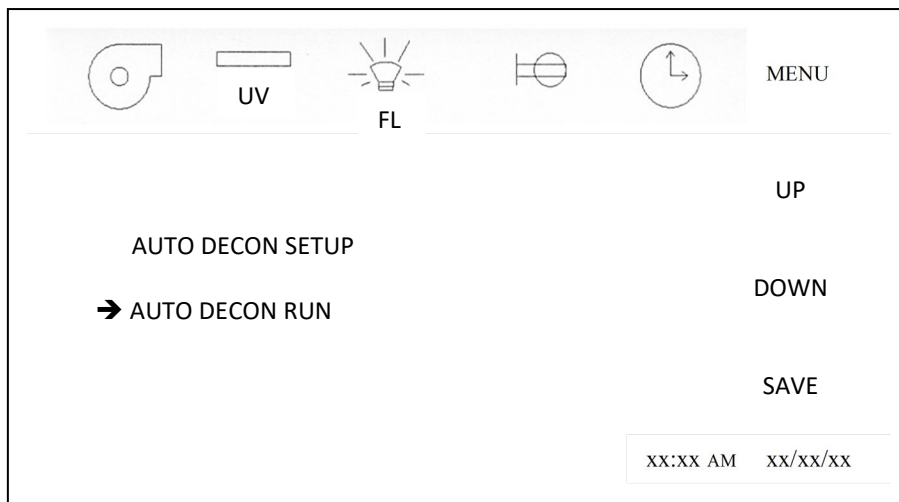

- Press Auto Decon Run.



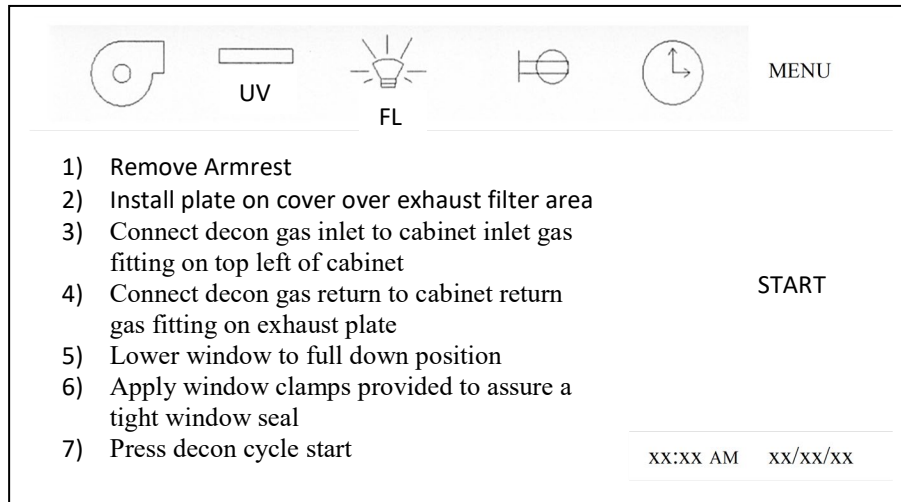

- Review process preparation list.
- Press start to initiate the cycle.

## 7.2 LED Lamp Replacement

The two (T8) LED bulbs are cool white, capacitor start and placed external to the cabinet to aid maintenance and minimize heat build-up within the cabinet. The B70 life rating of the bulb is 50,000 hours based on 80,000 switching cycles.

To replace a bulb, it is necessary to remove the lamp assembly.

1. Switch Cabinet Light Switch off
2. Remove the screws at each upper side of the Control Center and allow the Control Center to rotate down, resting on the safety straps
3. The bulb is now directly exposed for replacement
4. The lamp bulb is removed by displacing the bulb to one side against the compressible bulb holder and lifting out the lamp bulb
5. Reverse the procedure to reinstall the lamp assembly being careful not to pinch the safety straps, cable or tubing during closure of the control center

## 7.3 Primary HEPA Filter Prefilter Replacement

The primary HEPA prefilterers under normal usage and barring an accident (a puncture), do not need replacement until the efflux velocity cannot be maintained or the access inflow velocity cannot be maintained at 100 LFPM (.51 m/s) (min.). This may permit the average downflow velocity to be as low as 55 LFPM (.27 m/s), as long as no point falls below 20% of the average downflow velocity.

If the above airflow requirements cannot be maintained use the following procedure to replace the primary HEPA prefilterers.

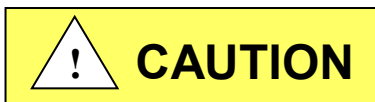

**Sliding window should never be opened unless interior is known to be free of hazardous drug residue or appropriate precautions are taken per facility Standard Operating Procedures (SOP'S).**

 **NOTE:** Cabinet should be on and running throughout the filter replacement process.

1. Using appropriate PPE, surface decontaminate or clean cabinet workzone interior including both sides of the worktray.
2. Remove worktray from cabinet and be sure window is at nominal work height.
3. Remove protective screen from primary HEPA prefilter that is going to be replaced and set aside within workzone.
4. Bend and collapse the protective screen then discard the protective screen by inserting it into the used filter that is to be replaced.

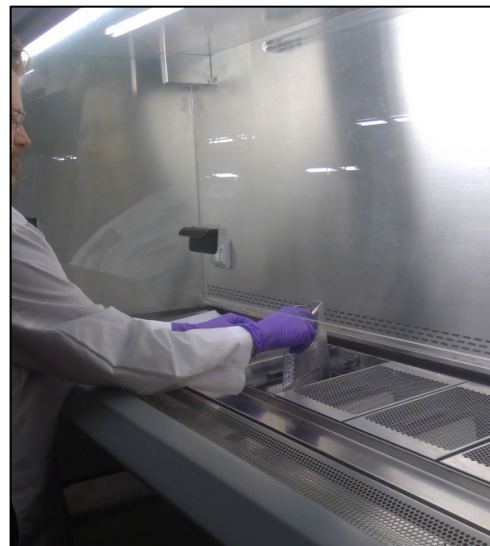
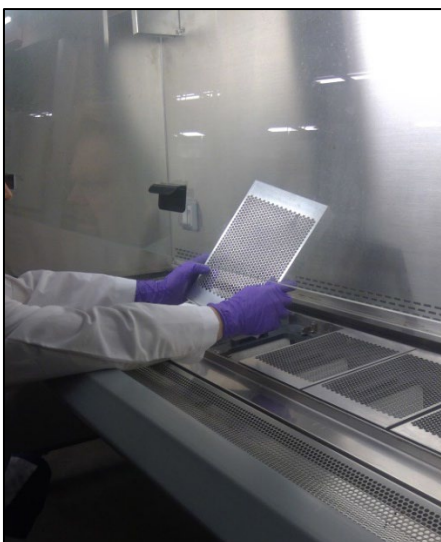

5. Clean top edge of prefilter with 70% IPA or similar cleaner and place wipe in prefilter. Install prefilter seal over the used prefilter.

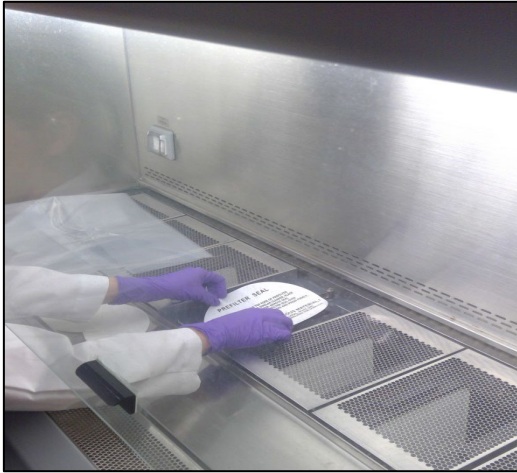

- 6a. Rotate both of the prefilter release clamps 90°

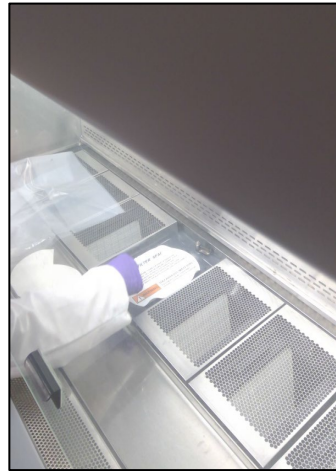

- 6b. Pull up and out prefilter of its position and lay on its side to be placed into bag.

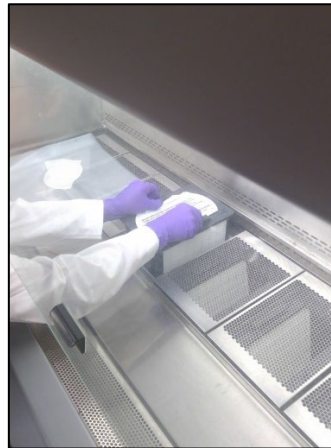

7. Place plastic bag over prefilter, gather at one end and tie up with wire tie.



8. Remove bagged prefilter from cabinet and place in appropriate transport container.



9. Before installing new HEPA prefilter, clean surface of filter gasket with 70% IPA. It is also recommended to apply a very thin layer of silicone grease on the gasket. If gasket is damaged (i.e. torn), replace it (Nuair part number A-3071-25). Proceed to install HEPA prefilter making sure filter is seated level onto the gasket.

 **NOTE:** Only use same type of HEPA prefilter to assure proper function of the cabinet.

10. Turn to engage stainless hold-down clamps (2) and replace protective screen.

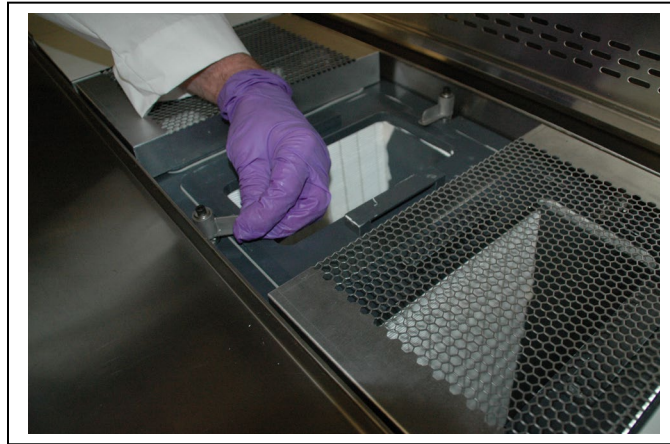

11. Repeat the process for each HEPA prefilter as needed until complete. (See section 7.6.1 for HEPA prefilter testing).



Hazardous Material!  
Follow all Local, State and Federal Guidelines for disposal.

## 7.4 Secondary HEPA Filter/Motor Replacement

The secondary HEPA filters (supply and exhaust) under normal usage and barring an accident (a puncture), do not need replacement.

The secondary HEPA filters should not be replaced until the entire cabinet has been decontaminated or known to be biologically "clean" and/or chemically inert.

### 7.4.1 Procedure



**Disconnect electrical power from the cabinet before attempting any maintenance action.**

**Step 1:** Remove screws at each upper side of the control center and allow the control center to rotate down, resting on the safety straps. Second, remove the front decorative panel which is held into position by (3) knurled nuts on the top edge and snap fit bullet catches on the bottom.

**Step 2:** Place sliding window into lowest position \* and remove front filter panel, which is held into position by Phillip pan head screws. Once the screws are removed, the panel is held into position by smooth weld studs located on the top corner of the front filter panel. Use the window stop brackets as handles to remove the panel.

 **Note: Screws are used in lieu of acorn nuts, and lock washers. The screws have O-rings and should be replaced if damaged or badly deformed.**

The interior of the cabinet is now fully exposed for replacement of the filters and/or motor/blower.

\*The lowest window position will require the armrest to be removed. If the cabinet has the power window option, access the Power Window Test menu to adjust the power window into its lowest position with the armrest removed. Access Calibration/Service menu, then Service menu, then Power Window menu to Power Window Test.

#### **Step 3: Filter Removal**

It is not always necessary to replace both the supply and exhaust filters at the same time. If during the course of certifications, the downflow always falls off while the exhaust increases the supply filter is "loading" faster than the exhaust filter and only the supply filter may need replacement. The opposite might also happen depending upon many factors.

- a. To remove the supply filter:
  1. Remove the plenum screws in front of the supply HEPA filter.
  2. Lift the permanent plenum and hold up with wire strap.
  3. Carefully remove the supply filter. Direct exposure should be avoided.

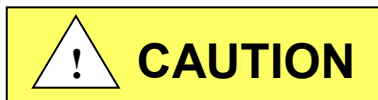

**Dispose of spent HEPA filters properly.**

**Avoid direct contact to "dirty side" of the filters.**

**Place in sealed bag and label all waste containers/cartons based on type of hazard. Follow all Local, State and Federal guidelines for disposal of HEPA filter solid waste.**

- b. To remove the Exhaust HEPA:
  1. Relax the exhaust filter seal loading mechanism by turning the four threaded bolts counterclockwise until one can see a definite release of the loading springs.
  2. Pull the exhaust choke tray free and remove the filter.  
It is not necessary to remove the tray, although it is free to move forward several inches, if necessary, to free the HEPA filter.

#### Step 4: Filter Installation

When installing new filters,

**USE ONLY NUAIRE SPECIFIED FILTERS FOR REPLACEMENT.**

Description:	Primary HEPA Prefilter	NuAire Part Number: A-980972-04
Efficiency:	99.97% @ 0.3 Micron	Filter Manufacturer: Camfil Farr
Airflow Rating:	270 cfm @ 0.52 ± .05 w.g. per sq. ft.	Primary HEPA Prefilter Quantities:
Frame Type:	Plastic Wedge Canister	400 (5), 500 (6), 600 (8)

Description:	Secondary Supply HEPA Filter	Secondary Exhaust HEPA Filter
Efficiency:	99.99% @ 0.3 Micron	99.99% @ 0.3 Micron
Airflow Rating:	100 fpm @ .48 ± .05" w.g. per sq. ft.	250 fpm @ .45 ± .05" w.g. per sq. ft.
Frame Type:	Metal	Metal

##### NU-581-400

NuAire Part Number:	A-980957-06	A-980957-18
Filter Size:	21" (533mm) x 44" (1118mm) x 3" (76mm)	20" (508mm) x 22" (559mm) x 11 1/2" (292mm)
Filter Manufacturer:	Camfil Farr	Camfil Farr

##### NU-581-500

NuAire Part Number:	A-980957-07	A-980957-19
Filter Size:	21" (533mm) x 56" (1422mm) x 3" (76mm)	20" (508mm) x 30" (762mm) x 11 1/2" (292mm)
Filter Manufacturer:	Camfil Farr	Camfil Farr

##### NU-581-600

NuAire Part Number:	A-980957-08	A-980957-20
Filter Size:	21" (533mm) x 68" (1727mm) x 3" (76mm)	20" (508mm) x 36" (914mm) x 11 1/2" (292mm)
Filter Manufacturer:	Camfil Farr	Camfil Farr

- a. To install the supply filter, simply reverse the procedure outlines in Step 3a, above.

 **NOTE:** Be sure to open the choke plate fully before inserting the filter into the tray. This will assist in adjusting the airflow.

- b. To install the exhaust filter, apply a thin layer of silicone grease to the top and bottom gaskets of the filter and carefully insert into the exhaust choke tray.

Position the filter frame within the outside walls of the exhaust opening on the top of the hood. Tighten the spring loaded bolts, 4 places, depressing the gasket material by 1/8 inch (3mm)

#### Step 5: Motor/Blower Assembly Removal

- a. It is recommended that the motor/blower to be removed as a single unit. To remove, disconnect electrical connections to the motor, remove the HEPEX pressure plenum and unbolt the motor/blower assembly from the roof of the cabinet (4 places). Always inspect the rubber isolation motor mounts and replace those that are cracked or visibly show stress.
- b. Replace the motor exactly as originally installed in the blower housing, paying particular attention to the correct electrical connections (see Electrical Schematic).
- c. Re-install the new motor/blower assembly.

## 7.5 Sliding Window Replacement & Manual Adjustment

The sliding window replacement is accomplished by removing the front decorative panel, control center, and window glide assemblies. The sliding window adjustment may be required due to everyday use over the life of the cabinet. Both the right and left window glides are adjustable by a set screw and tension screw method. When adjusting the sliding window, be sure to verify proper micro switch operation. If the sliding window is too loose, the sliding window will not properly activate the micro switches, thus causing potential operational malfunctions to occur. In addition, the sliding window retention or ability to slow the rate of fall, if a window counter balance experiences a fault, is also required to assure proper window function (see Sliding Window Retention Verification in the Inspection Report).

## 7.6 Airflow Control System Setup and Calibration

### 7.6.1 General

The operation of the NU-581 cabinet requires that the setup and calibration procedures be performed in order to certify or commission the cabinet for usage. The setup and calibration procedures performed **ONLY BY THE CABINET CERTIFIER** ensure that cabinet's setpoints are verified and that the airflow monitor sensors are calibrated to read the correct values. Press MENU to access Calibration/Service parameter.

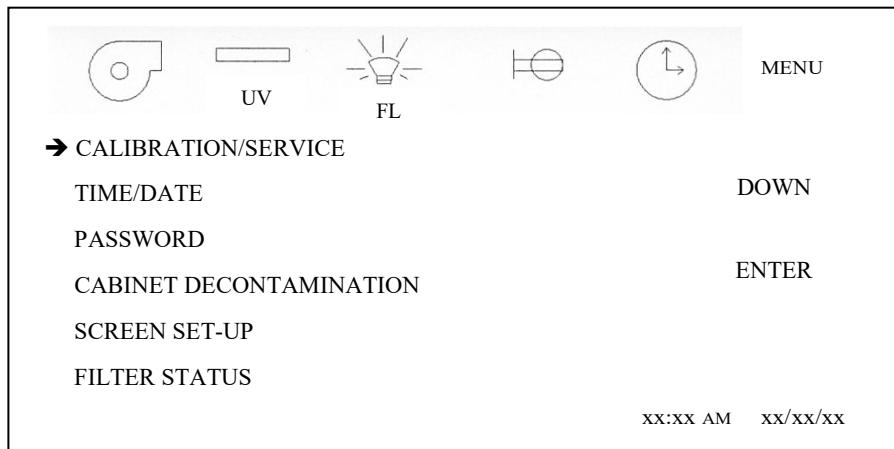

Entry into the Calibration/Service functions requires a service password for entry. After pressing the Calibration/Service menu item, a password screen will appear. The default password is "9876". Once the service password is entered, the Calibration/Service menu will appear.

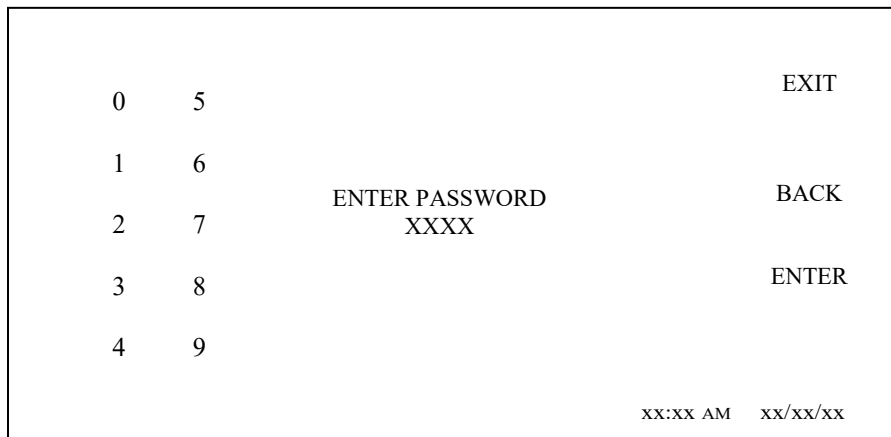

### 7.6.2 Calibration/Service Menu

The Calibration/Service menu provides a list of sub-menu items to accomplish all service tasks. For airflow calibration, only the first three sub-menu items are used in the calibration process.

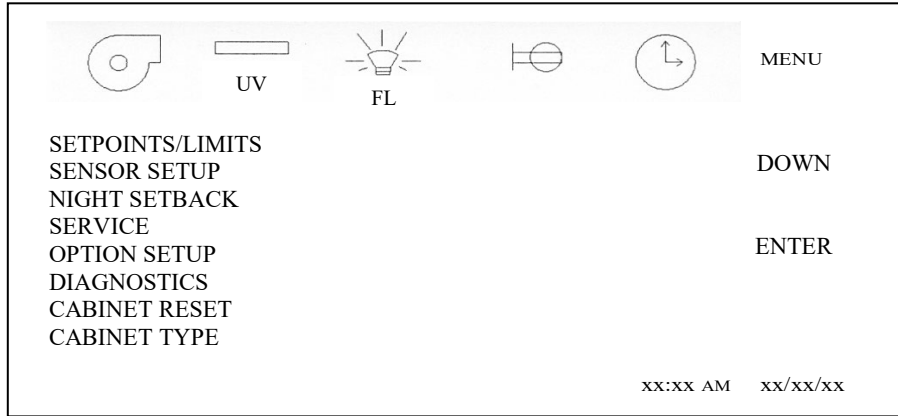

#### 7.6.2.1 Cabinet Type

The cabinet type can be verified in the control system and is factory set and shouldn't require alteration. The cabinet type default information controls unit of measure, setpoints and limits based on the type and size of cabinet.

To verify, press CABINET TYPE. The current type of cabinet will be designated. Again to verify, press the correct Type and the Model/Size of the current selected cabinet model will be designated. Once verified the correct type and model are designated, then press MENU to return to Calibration/Service menu.

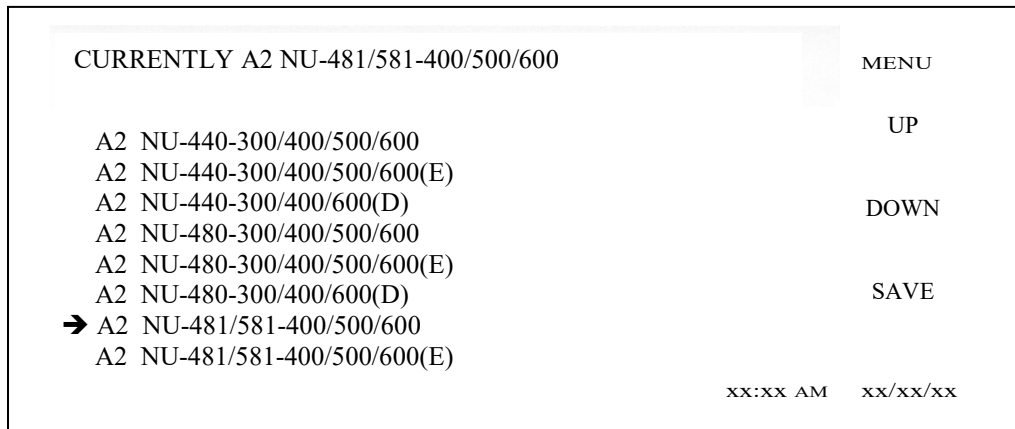
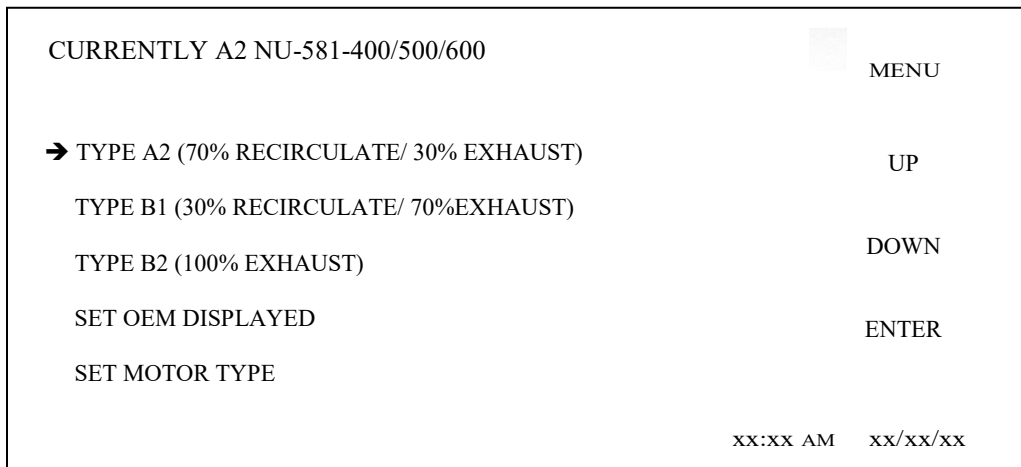



### 7.6.2.2 Setpoints/Limits

The airflow setpoints and alarm limits may also be verified or altered. Typically these default values are factory set based on the cabinet type, model and size as previously discussed. However, they may be altered in special cases for modified cabinets. The setpoint establishes the airflow values that are to be maintained. The high low limits establish the alarm boundaries from the nominal setpoint. The default values have been established based upon the performance specifications and cabinet component tolerances.

To verify or alter any of the airflow setpoints or alarm limits, press the menu setpoints/limits menu item. Then, press any of the individual setpoints or alarm limits to verify and/or change. Press UP or DOWN to change new value. Press SAVE to enter new value.

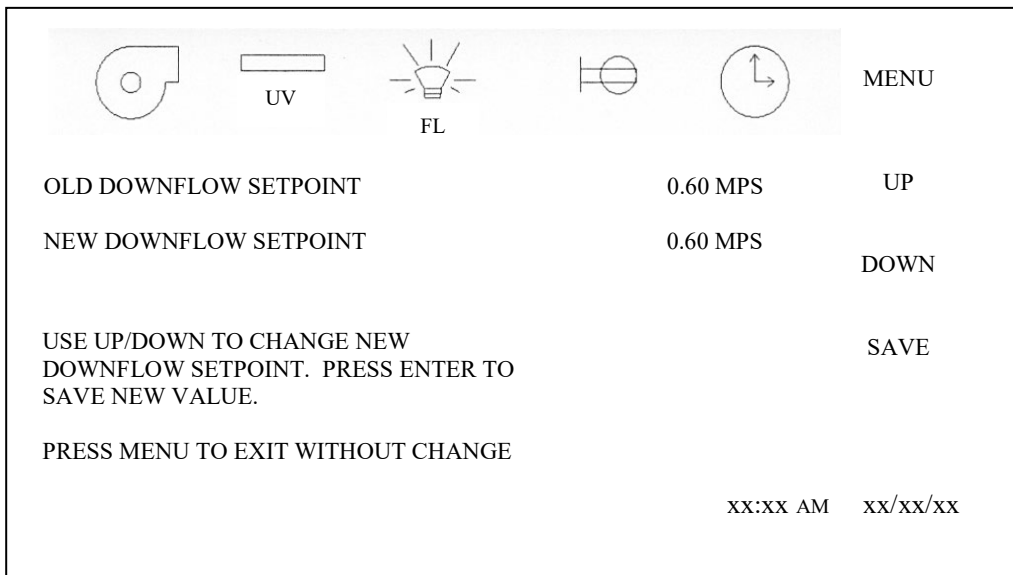
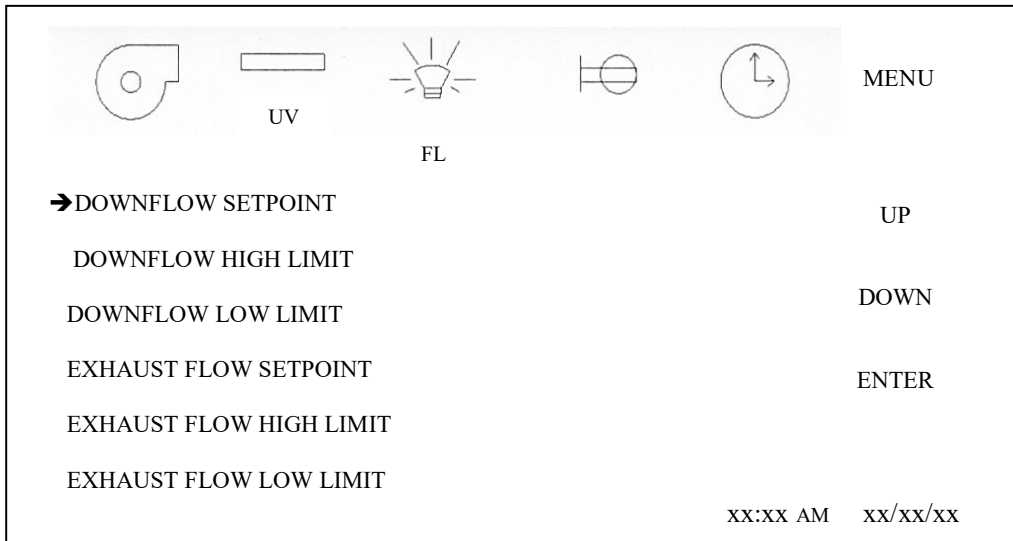

#### Default values for NU-581

- Downflow setpoint - 60
- Downflow high limit - 66
- Downflow low limit - 54
- Inflow setpoint - 105
- Inflow high limit - 120
- Inflow low limit - 90

### 7.6.3 Airflow Calibration

The NU-581 Airflow Calibration consists of adjustments to balance the airflow within the cabinet and the calibration of the airflow monitor sensors. **THIS WORK SHOULD BE DONE ONLY BY A QUALIFIED TECHNICIAN WHO CAN MEASURE THE AIRFLOW FROM THE FILTERS WITH A SUITABLE VELOMETER.** NuAire provides two adjustments to balance the airflow within the cabinet. These are:

- a. PWM signal adjust via DC ECM motor control system
- b. Exhaust filter choke

The blower speed control system adjusts the cabinet's total volume of airflow while the choke adjusts or balances the exhaust airflow as well as makes up for filter resistance tolerances. Since it has been NuAire's experience that the filters may not "load" evenly, both adjustments are necessary for proper cabinet performance.

The cabinet is considered to be certifiable if the following airflow measurements are present:

- a. Downflow average: 60 LFPM  $\pm$  5 LFPM (.30 m/s  $\pm$  .025 m/s).
- b. Inflow average: 105 LFPM  $\pm$  5 LFPM (.53 m/s  $\pm$  .025 m/s) using the Direct Inflow Measurement (DIM) method, or alternate 3" constricted inflow velocity measurement method.

The calibration of the airflow monitor sensors occurs during the cabinet airflow balancing procedure. The calibration procedure consists using the downflow and inflow averages achieved and entry of those values into the control system.

DC ECM motor PWM signal DC voltage should also be monitored and recorded upon final calibration. The DC voltage may be monitored using an independent digital voltmeter in the VDC mode. The two test points to measure DC ECM motor voltage are located on the DC motor signal connector on the main control board.

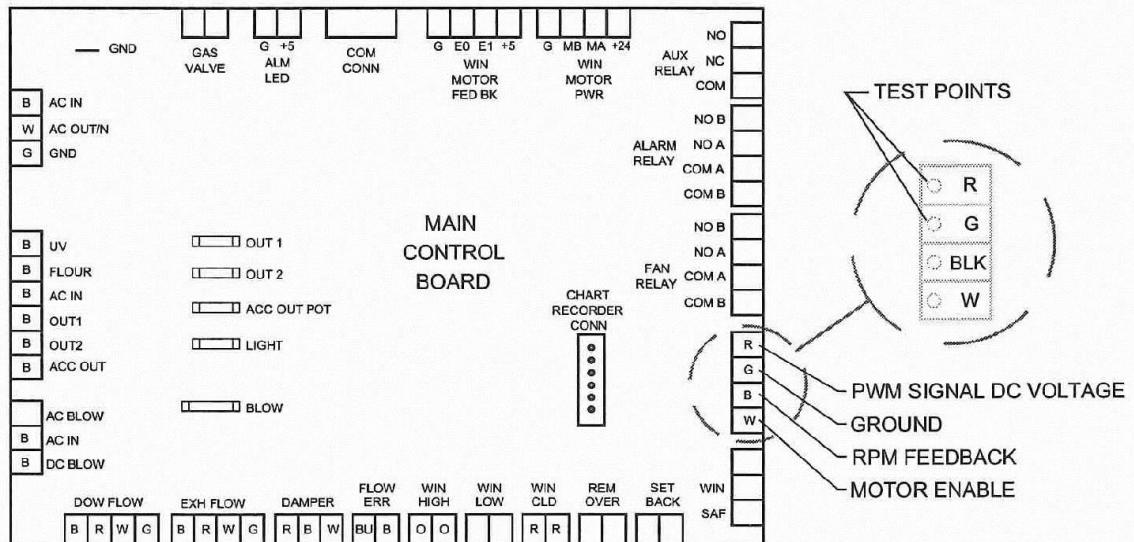

#### MOTOR VOLTAGE TEST POINTS

**BEFORE STARTING AIRFLOW CALIBRATION PROCEDURE,  
LET THE CABINET RUN FOR AT LEAST 10 MINUTES.**

### 7.6.3.1 Downflow Calibration

- Step 1: Access Calibration/Service menu.  
Press SENSOR SETUP menu item to access sensor calibration menu.

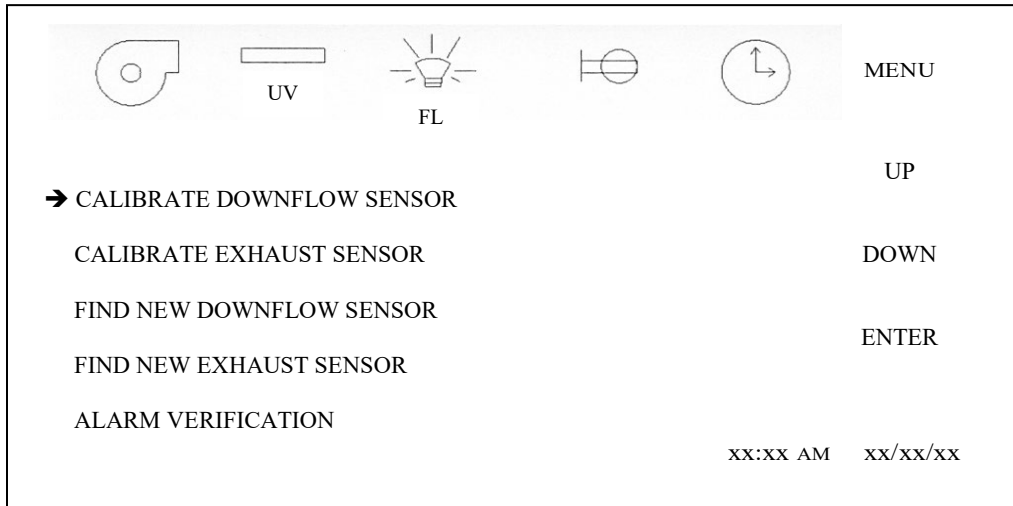

- Step 2: Press CALIBRATE DOWNFLOW SENSOR to access individual calibration screen.  
Press BLOWER switch to on. Allow blower to run for one minute or until downflow readings are steady.

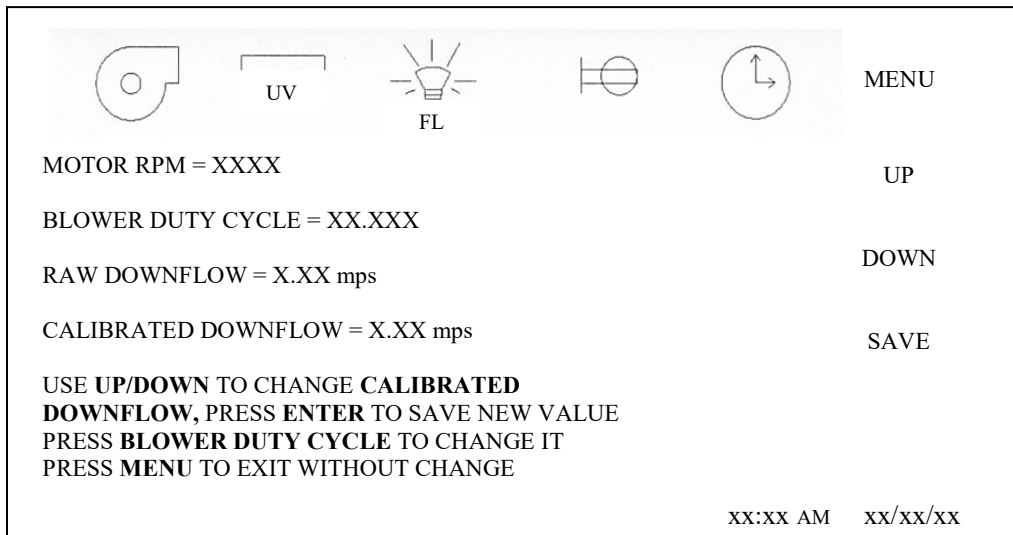

- Step 3: Place a velometer in the cabinet workzone on the horizontal plane 4 inches (102mm) above the bottom edge of the window.  
Spot check several points on the recommended downflow velocity test grid found in table 7.0.

- Step 4: Press BLOWER DUTY CYCLE to adjust blower speed.  
The objective of this spot check is to obtain the desired downflow average velocity as close as possible to the stated goal of 60 LFPM (.30 m/s).

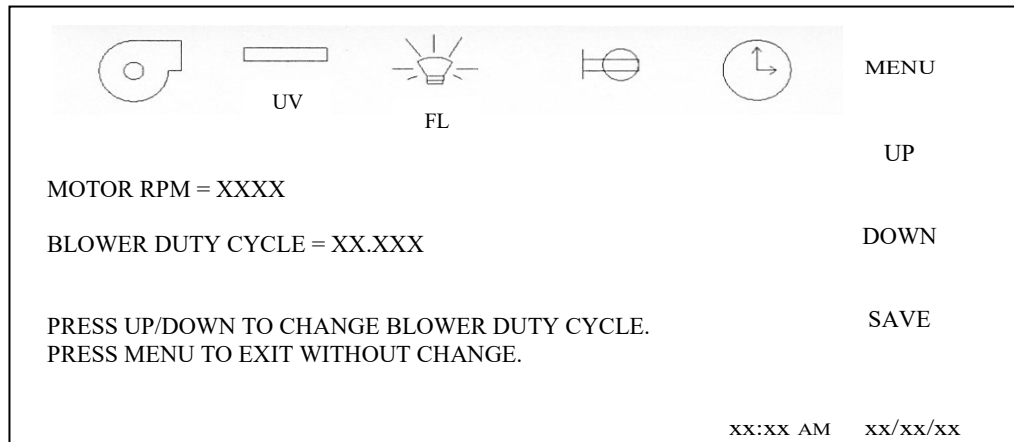

DON'T SPEND MORE THAN 5 MINUTES SPOT CHECKING.  
FINAL ADJUSTMENTS WILL BE MADE IN THE FOLLOWING STEPS.

Press SAVE to enter the current blower speed.

- Step 5: Now, measure the average downflow velocity over the entire workzone using the recommended downflow velocity test grid (see Table 7.0).

- Step 6: Press UP or DOWN arrows to change the calibrated downflow value to the average downflow velocity just found.  
Press SAVE to enter the new calibrated downflow value.

Now the downflow monitor sensor has been calibrated to the actual measured average downflow velocity. The cabinet will now control to the downflow setpoint.

- Step 7: Press MENU to exit back to the sensor calibration menu and blower will be turned off automatically.

### 7.6.3.2 Inflow Calibration

**Note:** INFLOW CALIBRATION MUST BE MADE IMMEDIATELY FOLLOWING DOWNFLOW CALIBRATION. THIS ASSURES THE CORRECT BALANCE OF DOWNFLOW TO INFLOW AS RELATED TO THE AIRFLOW MONITOR SENSOR CALIBRATIONS.

Step 1: Access sensor setup menu.

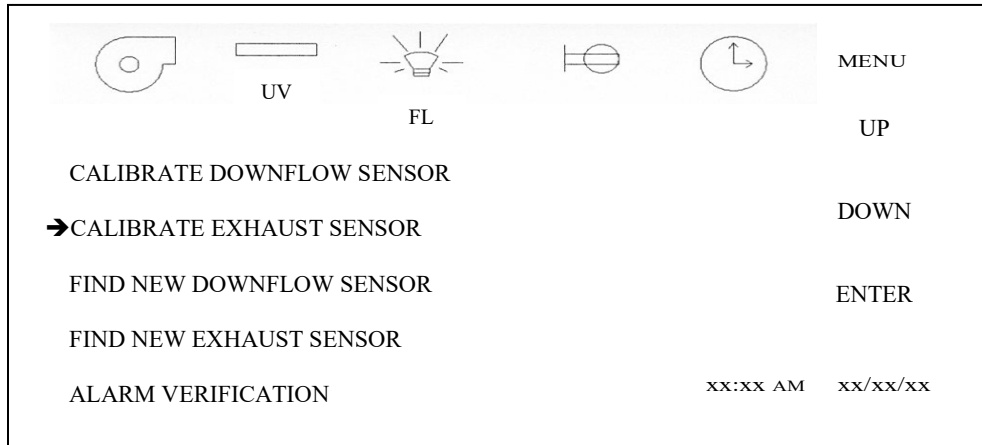

Step 2: Press CALIBRATE EXHAUST SENSOR to access individual sensor calibration screen. Press blower switch ON.

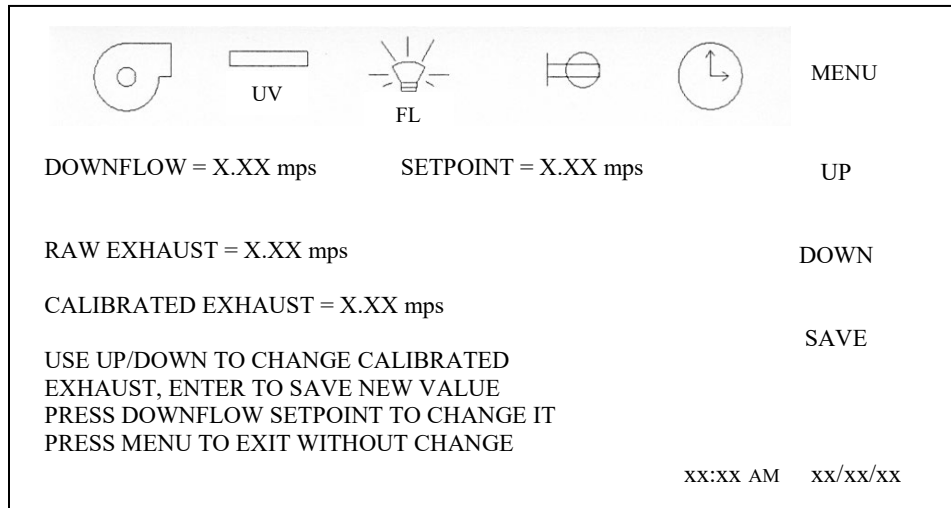

Step 3: Now measure the inflow velocity using the recommended procedure found in Table 7.0.

If necessary, adjust the exhaust filter choke located under the front decorative panel, to achieve the correct average inflow velocity within the stated range of  $105 \pm 5$  LFPM ( $.53 \pm .025$  m/s). IF THE AVERAGE INFLOW VELOCITY IS ON THE OUTER EDGE OF THE RANGE (I.E. 100 or 110 fpm ( $.51$  or  $.56$ m/s)). IT WOULD BE HIGHLY DESIRABLE TO MOVE IT CLOSER TO THE SETPOINT BECAUSE THE INFLOW MONITOR SENSOR ONLY FOLLOWS THE EXHAUST AIRFLOW OF THE BLOWER SYSTEM. There is no automatic exhaust control for inflow to setpoint via an actuator. However as a defaulted "ON" option, there is an Exhaust Auto CAL function that will periodically adjust the inflow display to setpoint. Having the inflow calibrated to the nominal setpoint will allow the system to run efficiently and accurately.

 **Note:** The choke plate adjustment requires standard blade screwdriver. To adjust, loosen the liquid-tight fitting around the choke adjustment shaft. While monitoring the exhaust flow to check position, turning the choke adjustment shaft clockwise will open the choke while turning counter clockwise closes the choke.

Step 4: Now the calibration procedure is complete. Return to the Run Mode using the menu icon to back out of the Calibration/Service menu. Press blower switch to initiate the warm-up cycle. Allow the blower to go through the entire warm-up cycle so the Exhaust Auto CAL process can take place at the end of the warm-up cycle.

 **Note:** If the Exhaust Auto CAL optional function is turned off the offset calibration must be performed when you are still in the Calibrate Exhaust Sensor menu.

- Press UP or DOWN to change the calibrated exhaust value to the average inflow velocity just found.
- Press SAVE to enter the new calibrated inflow value.
- Now, the calibration procedure is complete. If desired, a spot check in the downflow velocity may be performed if felt necessary. Replace the exhaust HEPA filter protective grill, if removed. If the inflow display changes due to the protective grill being present. Re-enter into Calibrate Exhaust screen and correct calibrated exhaust value.
- Once entire cabinet has been balanced, tighten liquid tight fasteners around choke adjustment shaft.

### 7.6.3.3 Alarm Verification

If desired, the alarm setpoint can be verified by entering into the alarm verification menu.

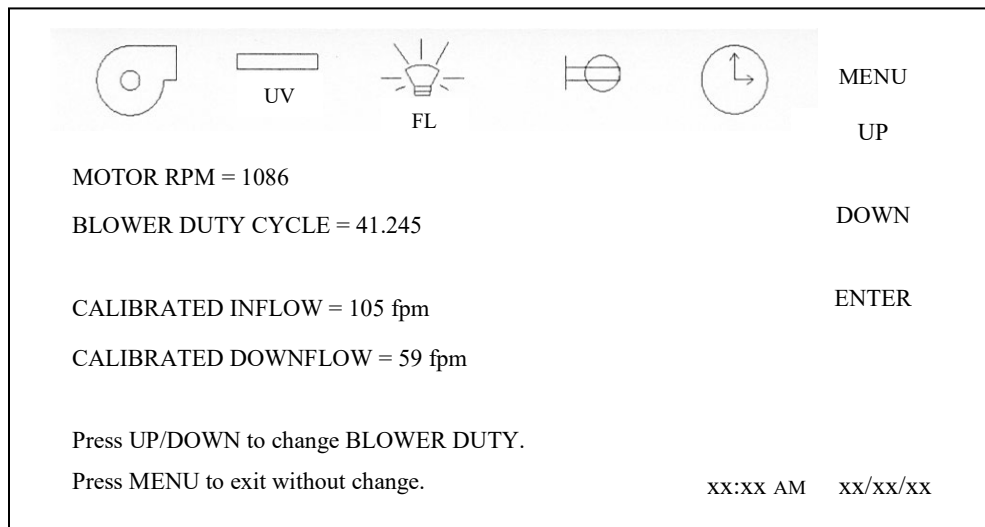
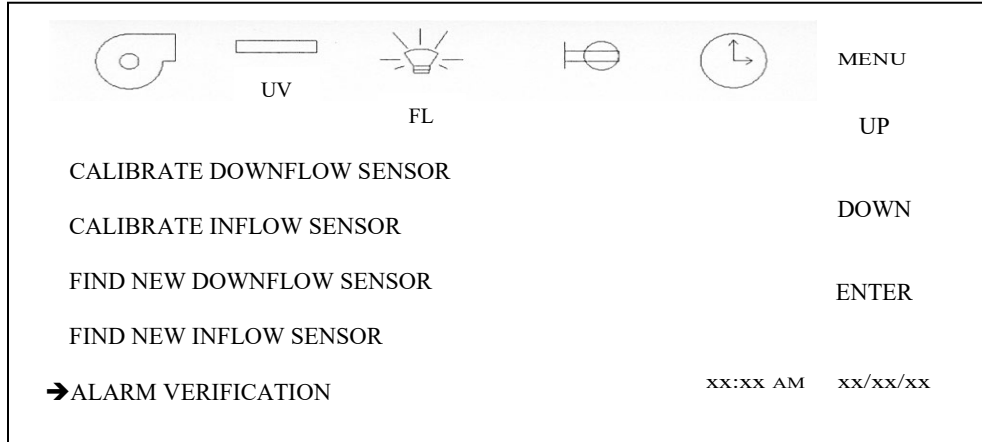

The airflow alarm is always active in this menu, so if the blower is turned on in this menu, an airflow alarm will be active until the airflow is above the low alarm limit.

Using the up and down key adjusts blower speed as necessary to activate a low or high airflow alarm. Measure either downflow or inflow at the alarm point to verify limits.

**Table 7.0  
Recommended Measurement Methods for Cabinet Downflow & Inflow**

**A. Downflow Measurement**

- a. Recommended Instruments: TSI 8355 Thermo anemometer
- b. Procedure: Supply filter efflux is measured on a grid, in a horizontal plane 4 inches (102mm) above the bottom edge of the window. No reading should be taken closer than 6 inches (152mm) from the inside perimeter.
- c. Test Data - Inches (mm):  
(Access Opening)

8"	10"											
400	400	6 (152)	11.729 (298)	17.458 (443)	23.187 (589)	28.916 (735)	34.645 (880)	40.375 (1026)				
500	500	6 (152)	11.797 (300)	17.594 (447)	23.391 (594)	29.188 (741)	34.985 (889)	40.782 (1036)	46.579 (1183)	52.375 (1330)		
600	600	6 (152)	11.838 (301)	17.676 (449)	23.514 (597)	29.352 (746)	35.190 (894)	41.028 (1042)	46.866 (1190)	52.704 (1339)	58.542 (1487)	64.375 (1635)
6 (152)	6 (152)											
10.540 (268)	10.460 (266)											
15.080 (393)	14.920 (379)											
19.620 (498)	19.380 (492)											

Number of Readings:	Average Velocity	ft./min.(m/s)
---------------------	------------------	---------------

- d. Acceptance Criteria:
  - 1. Average downflow velocity = **55 to 65 fpm (.28 to .33 m/s)**
  - 2. Individual readings must be within  $\pm 20\%$  or  $\pm 16\text{fpm}$  ( $\pm 0.08\text{m/s}$ ) whichever is greater (factory test) or  $\pm 25\%$  or  $\pm 16\text{fpm}$  ( $\pm 0.08\text{m/s}$ ) whichever is greater (field test) from the average downflow velocity.

**B. Inflow Measurement**

- a. Recommended Instrument: Shortridge Flowhood ADM-870 or TSI 8355 Thermo anemometer.
- b. Primary Procedure:  
The primary procedure to determine inflow velocity uses a Direct Inflow Measurement (DIM) Instrument (i.e. Shortridge flowhood). The DIM Instrument can be used directly on the cabinet with NO CORRECTION FACTORS REQUIRED if operated in the local density default mode. NSF has tested the cabinet and established listed air velocities expressed in local density. The DIM Instrument should also be duct taped to the cabinet to prevent any sneak air paths from occurring.  
  
The DIM Instrument will read inflow volume (i.e. CFM).  
Use the window access opening area to calculate inflow velocity.



**Alternate Procedure:**

The alternative procedure to determine inflow velocity uses a thermo anemometer in a constricted window access opening of 3 inches (76mm) with the armrest removed. Inflow air velocity is measured in the center of the constricted opening 1-1/2 inches (38mm) blow the top of the work access opening on the following specified grid. Use the correction factor table to calculate the inflow velocity.

c. Test Data - Inches (mm):

1. Dim Measurement

Inflow Volume	ft. <sup>3</sup> /min.(m <sup>3</sup> /s)	Access Opening	ft. <sup>2</sup> (m <sup>2</sup> )	Inflow Velocity	fpm(mps)
---------------	---	----------------	------------------------------------	-----------------	----------

2. Constricted 3 inch (76mm) high access opening measurement - Inches (mm):

400	4 (102)	8.264 (210)	12.528 (318)	16.792 (426)	21.056 (535)	25.320 (643)	29.584 (751)	33.848 (860)	38.112 (968)	42.375 (1076)						
500	4 (102)	8.198 (208)	12.396 (315)	16.594 (421)	20.792 (528)	24.990 (635)	29.188 (741)	33.386 (848)	37.584 (955)	41.782 (1061)	45.980 (1168)	50.178 (1274)	54.375 (1381)			
600	4 (102)	8.158 (207)	12.316 (313)	16.474 (581)	20.632 (524)	24.790 (630)	28.948 (735)	33.106 (841)	37.264 (946)	41.422 (1052)	45.580 (1158)	49.738 (1263)	53.896 (1369)	58.054 (1475)	62.212 (1580)	66.375 (1686)

Number of Readings:	Average Velocity of Constricted Area	fpm(mps)
---------------------	--------------------------------------	----------

Average Velocity of Constricted Area	fpm(mps) X Constricted Area	ft <sup>2</sup> (m <sup>2</sup> ) = Constricted Area Volume	CFM(m <sup>3</sup> /s)
--------------------------------------	-----------------------------	---	------------------------

Constricted Area Volume	CFM(m <sup>3</sup> /s)÷ 8" or 10" Access Window Area	ft <sup>2</sup> (m <sup>2</sup> )= Average Velocity of 8" or 10" Access Window Area	fpm(mps)
-------------------------	--	---	----------

Average Velocity of 8" or 10" Access Window Area	fpm(mps) X Correction Factor	=Average Inflow Velocity	fpm(mps)
--	------------------------------	--------------------------	----------

d. Acceptance Criteria: Access Opening Inflow Velocity = 100 to 110 fpm (.51 to .56 m/s)

**Areas/Correction Factors for Calculations**

Cabinet Size	3" (76mm) Constricted Window Access Area	8" (203mm) Window Access Opening	10" (254mm) Window Access Opening	Correction Factor for 8" (203mm) Window	Correction Factor For 10" (254mm) Window
400	.97 (.090)	2.58 (.240)	3.22 (.299)	1.20	1.21
500	1.22 (.113)	3.24 (.301)	4.05 (.376)	1.18	1.20
600	1.47 (.137)	3.91 (.363)	4.89 (.454)	1.18	1.15

## 7.7 HEPA Filter Leak Tests

In order to check filter and filter seal integrity, the HEPA filter media and seals must be directly accessible, by the measuring instrument. There are three separate sets of HEPA filters that must be checked: Primary HEPA Prefilters, Secondary HEPA Supply Filter and Secondary Exhaust HEPA Filter.

### 7.7.1 Primary HEPA Prefilters

This section will explain how to check the integrity of the HEPA prefilters that are located beneath the work surface. In order to properly validate these HEPA filters a challenge material must be introduced (PAO, or a similar challenge that can be detected using a particle counter) upstream of the primary filters. The scanning wand is used to dispense the particle challenge directly at a small section of each filter in order to help isolate the position of any leaks.

The following is needed to help check the filter integrity:

Particle generator Particle counter Paper or disposable clean room wipes.



**Sliding window should never be opened unless interior is known to be free of hazardous drug residue or appropriate precautions are taken per facility Standard Operating Procedures (SOP'S).**



**NOTE:** Cabinet should be on and running throughout the filter replacement process.

Using appropriate PPE, surface decontaminate or clean cabinet workzone interior including both sides of the worktray. Remove worktray from cabinet and be sure window is at nominal work height of 8" (203mm). Remove protective screen from primary HEPA prefilter that is going to be tested and set aside within workzone.

Start this procedure by accessing the calibration menu, press SENSOR SETUP menu, then press the CALIBRATE DOWNFLOW SENSOR menu, then press BLOWER DUTY CYCLE and change the speed of the motor to 850 RPM. Let the cabinet operate at the 850 RPM level through the primary HEPA prefilter testing procedure. However once completed **DO NOT SAVE** this RPM level but use **EXIT** to return to the main menu.

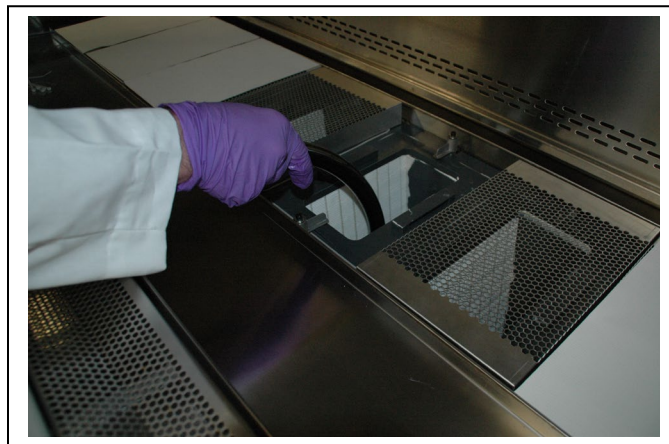

Cover the prefilter screens as needed per size requirements with paper or laboratory wipes to direct the airflow into the test prefilter.

Cover five prefilters for testing a 6ft (1.8m) cabinet  
or two prefilter for testing a 4ft (1.2m) cabinet  
or three prefilters for testing a 5ft (1.5m) cabinet.



To get the correct amount of challenge, introduce one Laskin Nozzle of PAO at 23 psi. Use a particle counter (set to .5 micron) for measuring the penetration rate thru the prefilters. Set the particle counter to "Beep" mode every 500 counts downstream of the HEPA prefilters, or visually count/watch particle counts to be aware of a sudden increase of particulate permeated through the HEPA filter. The challenge port is located on top of the cabinet. Note the background count before the PAO challenge is introduced.

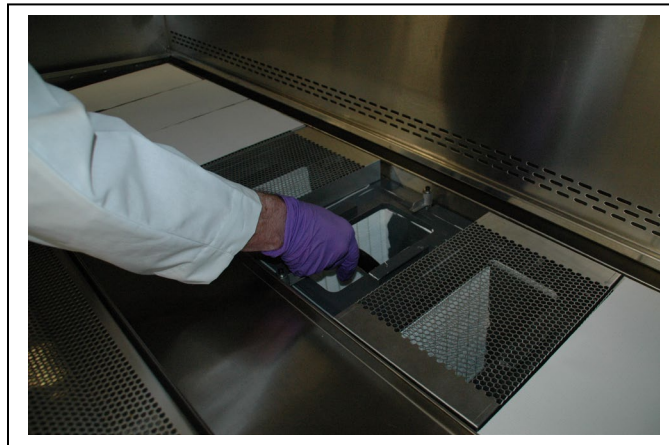

Direct the PAO from the generator outlet tube to the area of the HEPA prefilter that is exposed, Challenge the prefilters with the PAO wand by moving the generator outlet tube at a rate of 2cm per second and making sure the PAO is directed into the exposed pleats of the filter. Slow the traverse rate when a count of 500 particles every 2 seconds is detected, then re-scan the area of increased particulate release.

A leak is detected when a sustained particulate count is over 500 counts per second above the unchallenged background concentration.

### **7.7.2 Secondary Supply Filter**

The diffuser plate placed below the HEPA to protect the filter during normal usage may be removed as follows: The diffuser is secured to the cabinet shell by #1/4-20 acorn nuts located immediately behind the front viewing window. After removing the fasteners, drop the front of the diffuser plate several inches and pull forward gently. Note that the diffuser is purposely a tight fit - it is held to the back wall of the cabinet interior by a light push - fit with projecting studs. To avoid the window high alarm during the filter integrity check. It is desirable to enter the Calibration/Service menu and turn on the blower. The challenge material (i.e. PAO) should be supplied thru the challenge port located in front of the base of the cabinet (below the work access opening). The upstream challenge port being common for the supply and exhaust filters is located on top of the cabinet.

### **7.7.3 Secondary Exhaust Filter**

The exhaust filter is typically more difficult to check since protective grills, charcoal filters, or exhaust transitions could cover the filter. Access panels are usually provided and should be removed. If an air gap exhaust transition is provided, the air gap must be sealed with duct tape or other suitable means to prevent contaminated air from migrating into the exhaust efflux. All exhaust blowers/fans should be turned off during the check. The exhaust sensor shroud can also be removed for the exhaust filter integrity check. Replace the exhaust sensor shroud immediately after the filter check to assure proper operation. The challenge material (i.e. PAO) should be supplied thru the challenge port located in front of the base of the cabinet (below the work access opening). The upstream challenge port being common for the supply and exhaust filters is located on top of the cabinet.

**NOTE:** To avoid the window high alarm during the filter integrity check, it is desirable to enter into the Calibration/Service menu and turn the blower on. To accomplish this, perform the following:

Select Calibration/Service

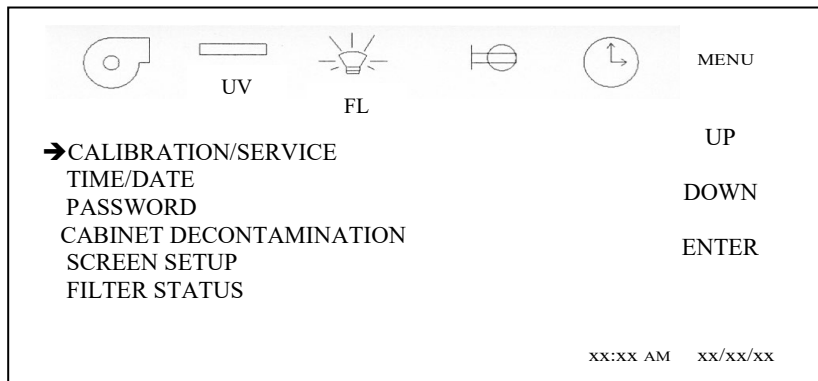

Entry into the Calibration/Service functions requires a service password for entry. After pressing Calibration/Service menu item, a password screen will appear. The default password is "9876". Once the service password is entered the Calibration/Service menu will appear.

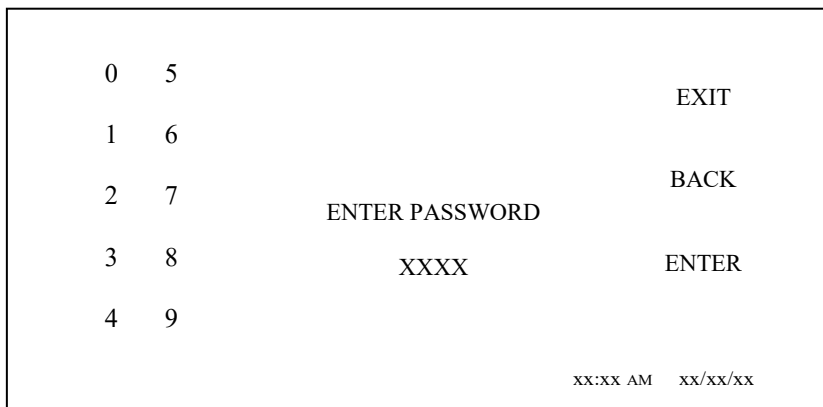

**NOTE:** If it is undesirable to use the upstream challenge port, use both downflow and exhaust volume for determining challenge concentrations. Use following area information below with average downflow velocity and spot-check exhaust velocities as measured to determine volume (CFM) (CMH).

<u>Model Size</u>	<u>*Supply Area (ft<sup>2</sup>)(m<sup>2</sup>)</u>	<u>Exhaust Area (ft<sup>2</sup>)(m<sup>2</sup>)</u>
400	8.53 (.792)	3.06 (.284)
500	10.74 (.998)	4.17 (.387)
600	12.95 (1.203)	5.00 (.465)

\* Measured 4 inches above the bottom edge of the window.

**Laskin Nozzle Concentration Formula**

$$\frac{\# \text{ Nozzles} \times 135 \text{ CFM} \times 100 \text{ ug/L}}{\text{Downflow (CFM)} + \text{Exhaust (CFM)}} = \text{Challenge Concentration (ug/L)}$$

$$\frac{\# \text{ Nozzles} \times 229 \text{ CMH} \times 100 \text{ ug/L}}{\text{Downflow (CMH)} + \text{Exhaust (CFM)}} = \text{Challenge Concentration (ug/L)}$$

## 7.8 Airflow Smoke Pattern Test

The airflow smoke pattern test is performed using a smoke source (i.e. smoke tubes) in and around the cabinet workzone and access opening to determine a visual representation of the cabinet's containment performance. To perform the test, the smoke source should be passed through the following areas:

1. A smoke source shall be passed from one end of the cabinet to the other, along the center line of the work surface, at a height of 4 inches (102mm) above the top of the access opening.
2. A smoke source shall be passed from one end of the cabinet to the other, 1 inch (25mm) just inside the view screen, at a height 6 inches (152mm) above the top of the access opening.
3. Pass a smoke source along the edges of the entire perimeter of the work opening approximately 1.5 inches (38mm) outside the cabinet, with particular attention paid to corners and vertical edges.
4. Pass a smoke source 2 inches (51mm) from the sides up inside of the window at the side channel seals, and along inside of the cabinet along the top of the work area or immediately below the wiper gasket.

The criteria used to evaluate the smoke patterns is the following:

1. The smoke inside the cabinet shall show smooth downward flow with no dead spots or reflux.
2. No smoke shall escape from inside the cabinet.
3. No smoke refluxes out of the cabinet once drawn in, nor does smoke billow over the worksurface or penetrate onto it.
4. No smoke shall escape from the cabinet.

## 7.9 Cleanliness Classification Test for Pharmacy Application

If this cabinet is going to be used within pharmacy, per USP797<sup>1</sup>, the cabinet must be tested to assure compliance to ISO 14644-1:2015, Cleanrooms and Associated Controlled Environments, Part 1: Classification of Air Cleanliness<sup>2</sup>. The cleanliness classification test is performed using a particle counter to measure particle counts within the cabinet workzone. Turn on cabinet and let warm up for several minutes. Turn on particle counter and flush out sample tubing line to remove latent particles. Set the particle counter to measure 0.5 micron or larger particles at the appropriate measuring rate.

### “Operational Particle Count Test”<sup>3</sup>

Position the particle counter isokinetic probe at a point 6 inches (152mm) upstream of the aseptic manipulation area (hand convergence point) and mounted so as not to interfere with the operator's hand movement. The pharmacy operator will simulate IV manipulation during the particle count test using non-hazardous materials. A minimum of three (3) 1-minute particle counts shall be sampled and recorded while the user simulates aseptic compounding manipulations.

### “At Rest Particle Count Test”

Take 5 test points in 1-minute intervals on a grid, in a horizontal plane as measured approximately 6 inches (152mm) above the worksurface. The grid location is designed as the workzone center point and each corner measured 6 inches (152mm) from the inside perimeter.

Record the 5 particle count values for each of the test points over the 1-minute sample time. All final count particle concentrations and calculated 95% upper confidence limit shall not exceed 3520 particles per cubic meter (ppcm) or (100 particles per cubic feet (ppcf)).

<sup>1</sup> USP28-NF23: United States Pharmacopeial Convention, Inc., 12601 Twinbrook Parkway, Rockville, MD 20852, USA, [www.usp.org](http://www.usp.org).

<sup>2</sup> ISO 14644-1:2015 Cleanrooms and Associated Controlled Environments-Classification of Air Cleanliness, International Organization for Standardization, Case Postale 56, CH-1211 Geneve 20, Switzerland

<sup>3</sup> CAG-002-2006: CETA Compounding Isolator Testing Guide, Controlled Environment Testing Association, 1500 Sunday Drive, Suite 102, Raleigh, NC 27607, USA, [www.cetainternational.org](http://www.cetainternational.org)

### 7.10 Main Control Board Description & Replacement

To access the main control board for fuse or board replacement, remove screws at each upper side of the control center and allow the control center to rotate down, resting on the safety straps. Now the main control board is exposed for service.

#### 7.10.1 Main Control Board Replacement

The main control board consists of two interconnected Printed Circuit Board (PCB) assemblies. The front PCB contains the LCD display. The back PCB contains the power supply, configuration switch, sensor inputs/outputs and control inputs/outputs components. The mechanical and electrical interconnects for the two PCB's all occur within the assemblies and are fastened together with standoffs and screws.

#### 7.10.2 Main Control Board Fuse Replacement



Disconnect electrical power from cabinet before fuse replacement.

All AC circuits are fuse protected and when replacement is necessary, **USE ONLY FUSES OF SAME TYPE AND RATING FOR PROTECTION AGAINST RISK OF FIRE.**

DESCRIPTION:	BLOWER FUSE	OUTLET FUSE	ACCESSORY OUTPUT FUSE	LIGHT FUSE	POWER INPUT FUSE
FUSE TYPE:	TIME-LAG	TIME-LAG	TIME-LAG	TIME-LAG	SUB-MIN (250V)
FUSE SIZE:	1/4 X 1-1/4 INCH	5 X 20MM	5 X 20MM	5 X 20MM	TR-5
NU-581-400	15 AMPS	3 AMPS	2 AMPS	1 AMP	4 AMPS
NU-581-500	15 AMPS	3 AMPS	2 AMPS	1 AMP	4 AMPS
NU-581-600	15 AMPS	3 AMPS	2 AMPS	1 AMP	4 AMPS

#### 7.10.3 Main Control Board Replacement

**Note: All setup and calibration data will be lost**, the memory reinitialized to the default values and all control functions reset to an initial cabinet power condition. If possible, before the main control board replacement, it would be preferred to know the operational parameters of the cabinet, (i.e. motor/blower voltage, setpoints, and airflow data from previous certification.

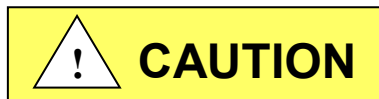

Disconnect electrical power from the cabinet before attempting any maintenance action.

The main control board is fastened to the control center with (6) 6-32 screws. All electrical connections are made with removable terminals and/or Faston connectors except for the motor/blower connector which uses a screw terminal. Remove all electrical connections and fasteners then remove the main control board from the control center.

Install new main control board by reattaching all electrical connections and fasteners. Once installed, rotate control center to normal position and fasten in place.

Now reconnect power to cabinet. Upon BSCC system power up, a system master reset must be performed to clear the microprocessors non-volatile memory to assure proper system function.

#### 7.10.4 Cabinet Reset

The main control board has two software operating resets available for qualified service personnel. The two types are the following:

Factory Reset - Resets setpoints and selected option settings. Factory reset should be used in the event the system memory develops an error in operation. Cabinet type, motor type and calibration data will not be affected with this reset.

Master Reset - Resets all calibration, cabinet type, motor type, sensor data, and options settings back to default settings. Master reset should only need to be used for a main control board replacement.

After pressing the Calibration/Service menu item, a password screen will appear. The default password is "9876". Once the service password is entered, the Calibration/Service menu will appear.

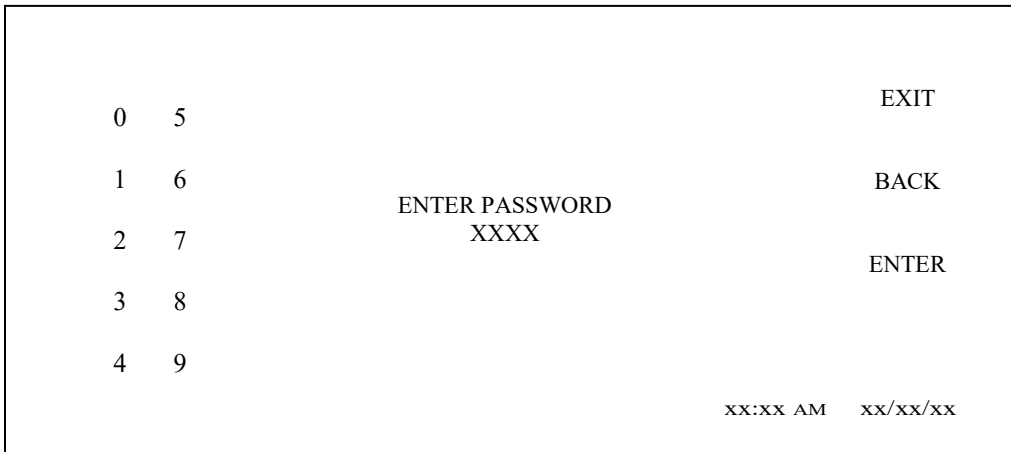

- Select CABINET RESET from the menu.

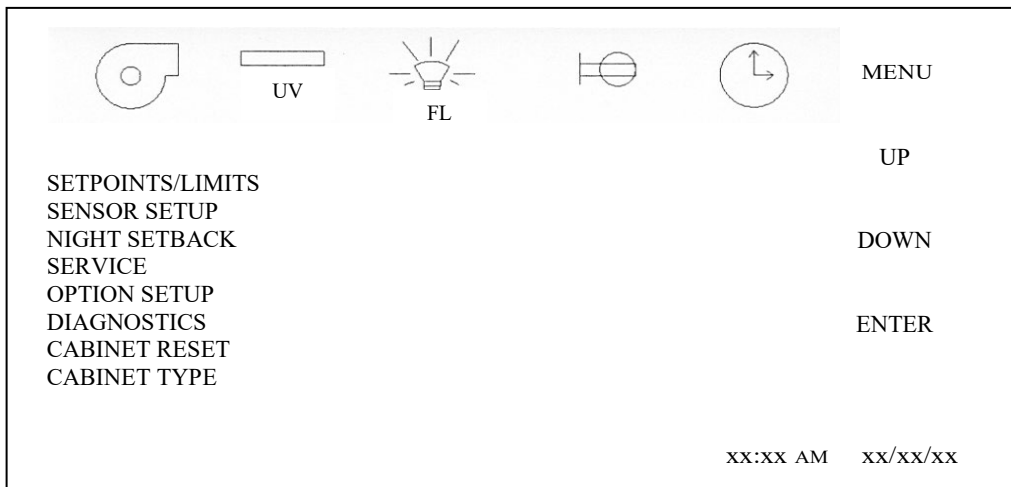



- Select desired function from menu.

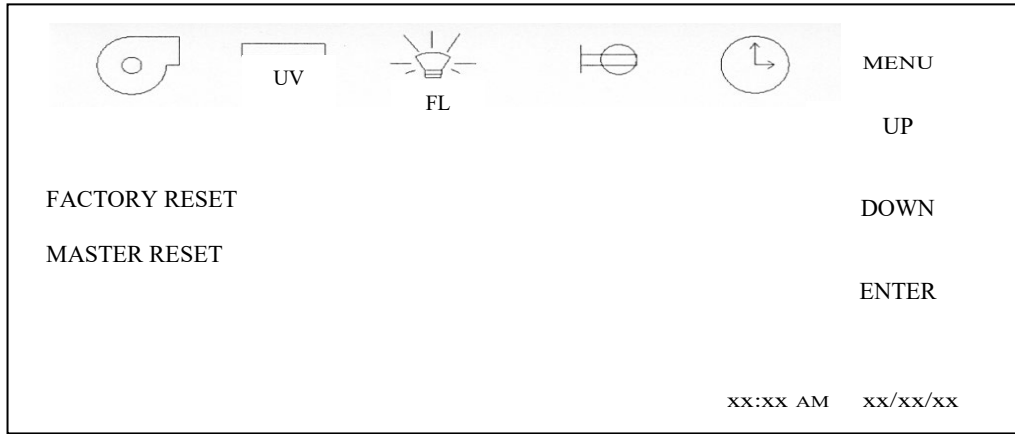

- Perform either reset function as selected below.

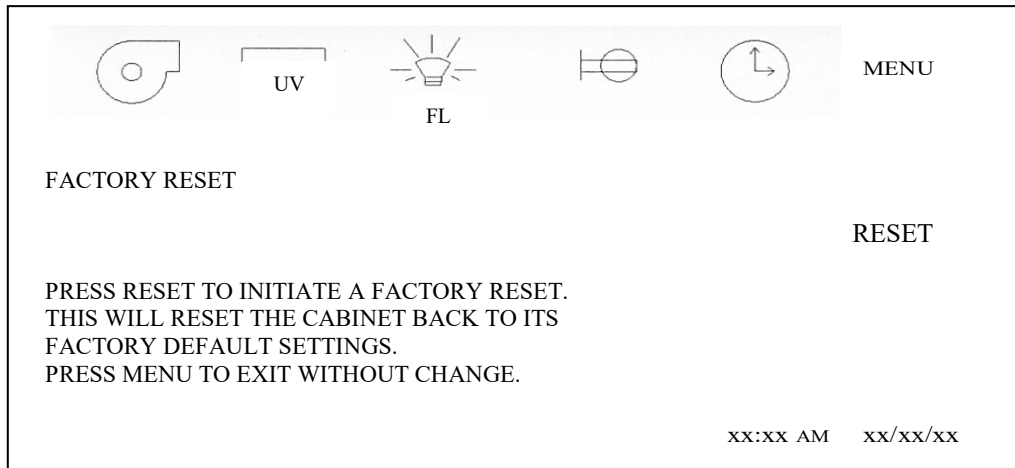

- Once factory reset is complete, return to Calibration/Service menu to enter any options.

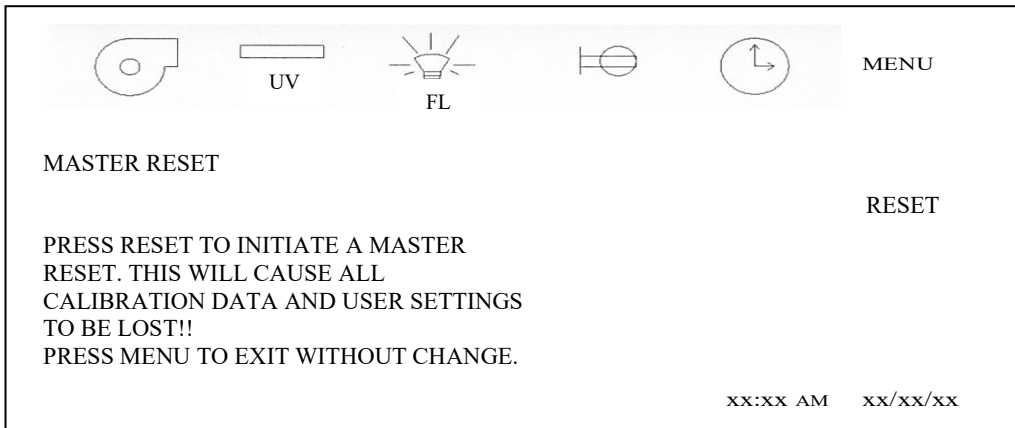

Once the MASTER RESET icon is pressed, the display screen will remain the same for approximately 1 minute. Also during this 1 minute, an audible signal of the reset process will occur. Once the reset process is complete the display screen will revert back to the NuAire logo main menu. At this point the cabinet MUST be turned off to complete the process. Either unplug the cabinet or use the power switch within the control center to turn off the cabinet. Turn the cabinet back on the display screen will remain blank for up to a minute, then will indicate "Power Loss Alert", press the screen to clear the message and return to the Calibration/Service menu to enter cabinet type, motor type, verify setpoints, find sensors and perform airflow calibration.

### 7.11 Digital Airflow Sensor Description & Replacement

The airflow sensor function utilizes two thermistors that provide a constant current source. One thermistor is a reference that uses a very low current source. The other thermistor is the airflow measurer that uses a very high current source. As airflow passes over the thermistors, the airflow removes heat from the thermistor measuring airflow. The loss of heat from the thermistor causes the voltage from the thermistor to increase. This increase subtracted from the reference thermistor output voltage is what directly relates to airflow velocity. A repeatable curve can be generated (voltage vs. airflow velocity).

The thermistors used are glass bead and coated and can be cleaned by gently using a cotton swab and alcohol. Formaldehyde gas, Hydrogen Peroxide and Chlorine Dioxide has no effect on the airflow sensors; however, the formaldehyde/Ammonium bicarbonate residue that remains after decontamination should be removed from the airflow sensor thermistors.



**Disconnect electrical power from the cabinet before attempting any maintenance action.**

The airflow sensors are removed by turning the locking ring counterclockwise and gently pulling the sensor away from the connector. To reattach the airflow sensor, turn sensor in keyed connector until key matches, push in and turn the locking ring clockwise until ring locks.

Once the new sensor(s) have been replaced, proceed to the digital sensor setup procedure in section 8.

## 8.0 Error Messages, Troubleshooting, Option-Diagnostics & Airflow Sensor Performance Verification

Audible alarms and error messages occur for a variety of reasons. Whenever an alarm condition has been present for a period of at least 10 seconds, the audible alarm/error message will be presented and stay on until the error is cleared. The audible alarm will be on for 30 seconds upon initial alarm condition, then once every ten seconds. When presented with an error message, please perform the following:

Step 1: NOTE ALL ERROR MESSAGES.

Error message will appear in place if the NuAire logo with "Active Alarms" and the alarm type below.

Step 2: VERIFY ERROR MESSAGES.

Error messages can be verified by cleaning the error function by either turning the blower or the cabinet on and off.

Step 3: MONITOR RE-OCCURRENCE OF ERROR MESSAGES.

If re-occurrence of the error message is immediate or daily, use guide below to correct the situation.

## 8.1 Error Message Troubleshooting Guide

Error Message	Indicator	Correction
– Window Alarm (Window High)	Sliding window is above its standard working height or micro switch is not operating properly.	Verify standard working height and window micro switch operation.
– Window Alarm (Window Low, ONLY with Power Window option)	Sliding window is below its standard working height or micro switch is not operating properly.	Verify standard working height and window micro switch operation.
– Airflow Alarm – Red Downflow Arrow (Downflow Low Limit)	Downflow airflow fell below its lower limit alarm setpoint.	Re-certify cabinet to proper airflow setpoints.
– Airflow Alarm – Red Downflow Arrow (Downflow High Limit)	Downflow airflow went above its high alarm setpoint.	Re-certify cabinet to proper airflow setpoints.
– Airflow Alarm – Red Inflow Arrow (Inflow Low Limit)	Inflow airflow fell below its lower limit alarm setpoint.	Check orientation of exhaust sensor shroud. Re-certify cabinet to proper airflow setpoints.
– Airflow Alarm – Red Inflow Arrow (Inflow High Limit)	Inflow Airflow went above its high alarm setpoint.	Check orientation of exhaust sensor shroud. Re-certify cabinet to proper airflow setpoints.
– Low Pressure Alarm (Low pressure Limit)	Indicates low pressure or low cabinet airflow	Re-certify cabinet to proper airflow setpoints.
Cabinet fluorescent lights won't turn on.		Check light fuse on main control board. Check fluorescent lamps. Check voltage coming out of main control bd. to light ballast's. Check light starters, if present. Check ballast.
Cabinet blower won't turn on.		Check blower fuse on main control board. Check voltage coming out of main control board. Check wiring to blower. Check blower motor. (Note: blower motor has internal thermal protector. Let blower motor cool off for a minimum of 30 minutes to assure thermal protector is not open).
Display indicates (Remote Override Active)	Indicates that the remote over-ride is activated, preventing the usage of the cabinet	
Power Loss Alert!	Indicates a power interruption has occurred.	Press display to clear message.
Cabinet outlets won't turn on.		Check outlet fuse located on main control bd. Check voltage coming out of main control board.
Cabinet ultraviolet light won't turn on.		Check sliding window position so that it's fully closed. Check blower/lights fuse on main control board. Check voltage coming out of the main control board to ultraviolet light ballast. Check light starters, if present. Check ballast.
Blower or light fuse continues to blow after replacement.		Check for short on output of fuse. Isolate output of fuse by disconnecting light circuit, blower circuit, etc. to isolate short.
Replace UV Light!	Indicates that the UV light needs replacement	Replace UV light and clear UV run time clock.
Display indicates (Night Setback Active)	Indicates that the night setback is activated, preventing the usage of the cabinet.	
Power window option is malfunctioning.	Window does not open and close correctly	Try to fully open the window to initiate the self-calibration feature. Activate the auto-reverse function by placing a soft object, i.e. rubber stopper under window and lower until window auto reverses and is raised to its self-calibrating point. Re-calibrate power window memory points.
Active Alarms DN Sensor Comm! EX Sensor Comm!	Indicates a digital communication error from the main control board to the airflow sensors.	Check connectors and wires from main control board to the airflow sensors. DN indicated downflow sensor. EX indicates exhaust sensor.
Active Alarms DN Sensor Error! EX Sensor Error!	Indicates an error signal generated by the sensor.	Check airflow probe connector on main board. (Ref. Section 7.11) Replace airflow sensor if required.

## 8.2 Calibration/Service Menu

### 8.2.1 General

As with the airflow calibration process, the service menu should only be accessed by a Service Technician that is familiar with the product.

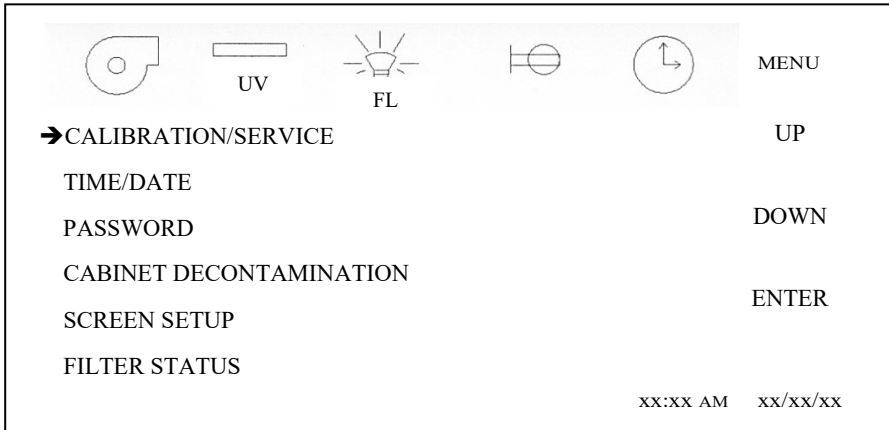

Entry into the Calibration/Service functions requires a service password for entry. After pressing the Calibration/Service menu item, a password screen will appear. The default password is “9876”. Once the service password is entered, the Calibration/Service menu will appear.

As a special feature for the service technician, by accessing the Calibration/Service menu, the service technician can bypass the blower warm up time itself. This feature remains on for one hour from the time the Calibration/Service menu was accessed. When bypassing the warm up time, it is not uncommon to experience a brief alarm as the blower stabilizes at setpoint.

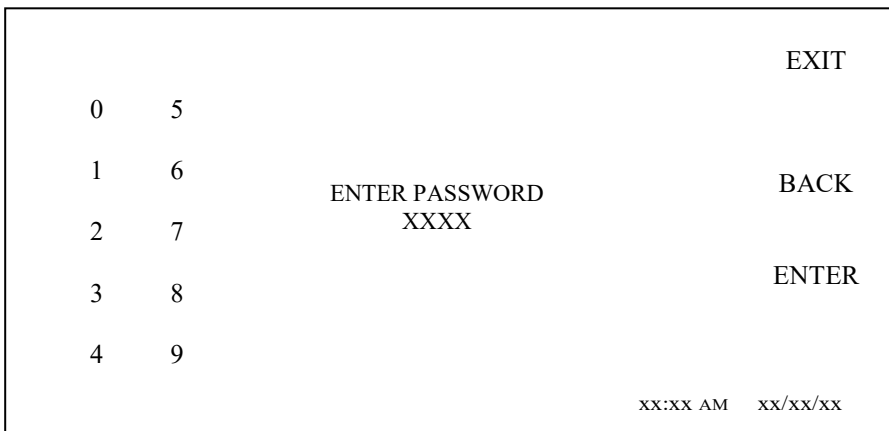

## 8.2.2 Calibration/Service Menu

The Calibration/Service menu provides a list of sub-menu items to accomplish all service tasks. Each sub-menu item will be described in the following sections.

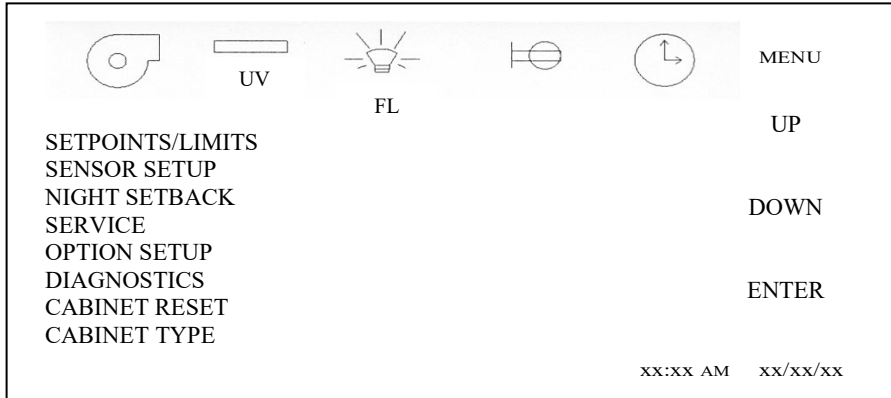

### 8.2.2.1 Cabinet Type/Motor Type

The cabinet type can be verified or changed in the control system. The cabinet type default information controls unit of measure, setpoints and limits based on the type and size of cabinet.

To verify, press Cabinet Type. The current type of cabinet will be designated. Again to verify, press the correct Cabinet Type and the Model/Size of the current selected cabinet model will be designated. Once verified the correct type and model are designated, then press MENU to return to Calibration/Service menu.

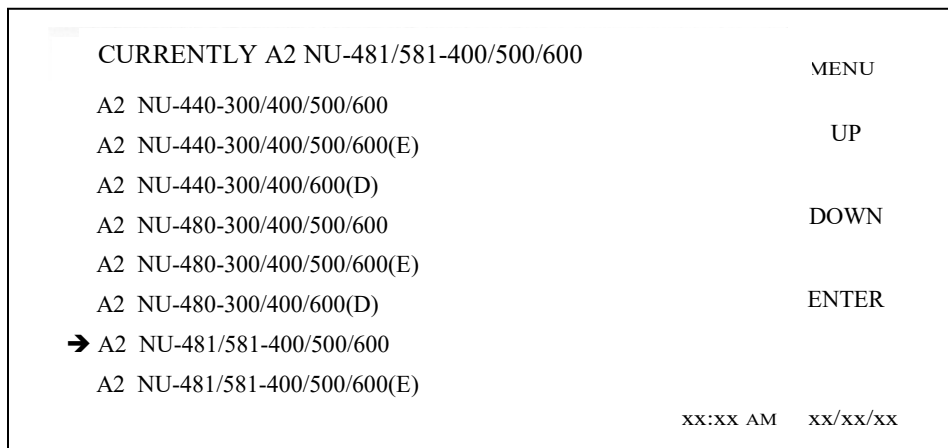
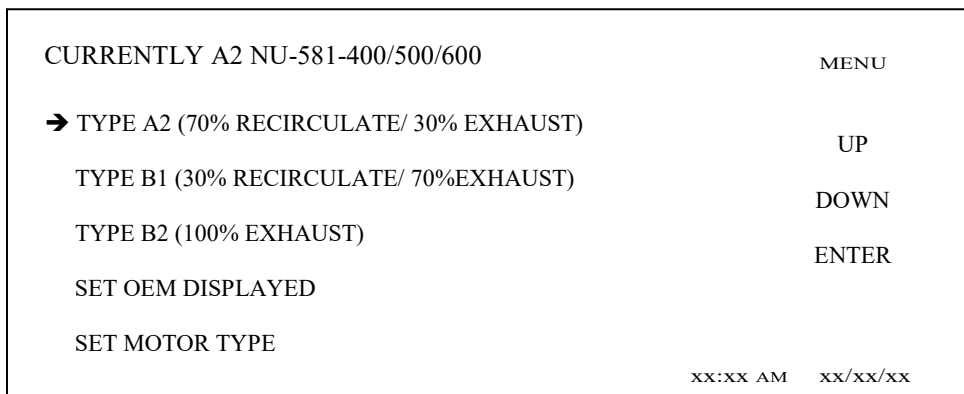

Press SET MOTOR TYPE to verify correct setting. Upon a MASTER RESET, the motor type is defaulted to AC.

**The NU-581 Series 1 (115 Vac) requires the motor type selected to be DC.**

Always verify motor type when verifying cabinet type.

### 8.2.2.2 Setpoints/Limits

The airflow setpoints and alarm limits may also be verified or altered. Typically these default values are factory set based on the cabinet type, model and size as previously discussed. However, they may be altered in special cases for modified cabinets. The setpoint establishes the airflow values that are to be maintained. The high low limits establish the alarm boundaries from the nominal setpoint. The default values have been established based upon the performance specifications and cabinet component tolerances.

To verify or alter any of the airflow setpoints or alarm limits, press the menu setpoints/limits menu item. Then, press any of the individual setpoints or alarm limits to verify and/or change. Press UP or DOWN to change new value. Press SAVE to enter new value.

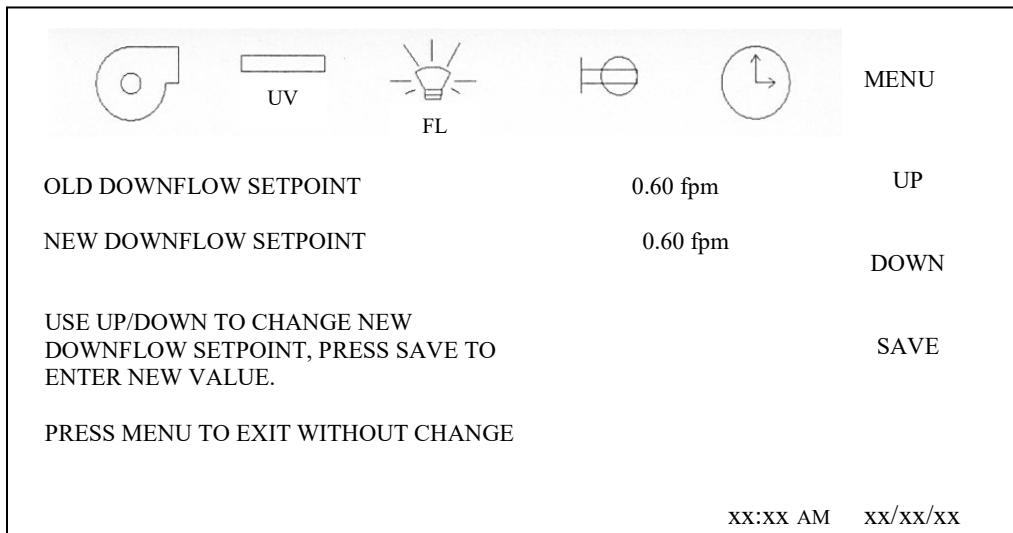
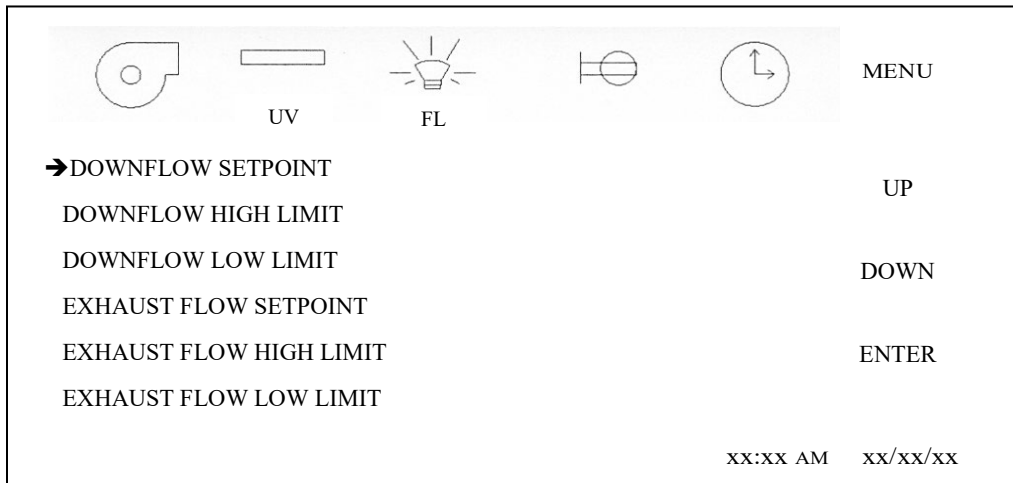

#### Default values for NU-581

- Downflow setpoint - 60
- Downflow high limit - 60
- Downflow low limit - 54
- Inflow setpoint - 105
- Inflow high limit - 120
- Inflow low limit - 90

### 8.2.2.3 Digital Sensor Setup

The sensor setup menu is used for both calibration and sensor replacement if necessary. For sensor calibration process, see airflow calibration section. For sensor replacement, use the “Find new downflow / exhaust” menu’s below. This would also be required after performing a MASTER RESET.

If finding or replacing one or both sensors, the downflow sensor will always have to be connected and found first. To find or replace one or both sensors, perform the following procedure:

- Disconnect power to cabinet.

 **NOTE:** A power switch is available in the control center to turn the cabinet on and off.

**Connection and disconnection must always be performed with the cabinet power off.**

- Replace one or both airflow sensors.
- Reconnect only the downflow sensor at this time.  
Leave exhaust sensor connector that runs to the main control board disconnected.
- Reconnect power to cabinet and navigate to the sensor setup menu.
- Select “FIND NEW DOWNFLOW SENSOR”, and follow menu.
- Press “LEARN” to find sensor. If successful, display will indicate SENSOR FOUND, if not, display may indicate SENSOR ALREADY USED or FAILED TO FIND SENSOR. If this is the case, perform MASTER RESET and start process over.

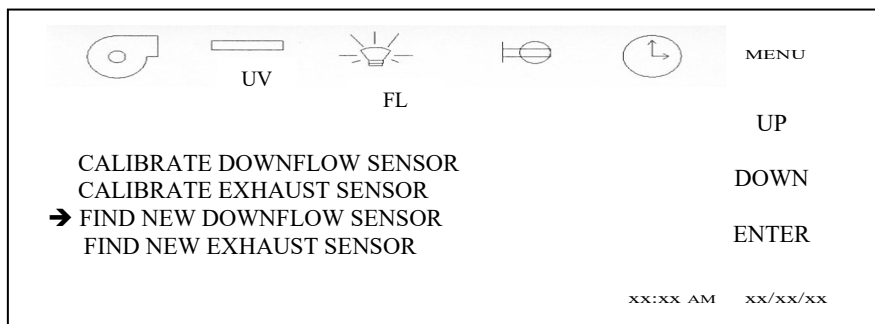

- Once downflow sensor is found, turn off the power to cabinet and reconnect exhaust sensor and disconnect downflow sensor.
- Turn power back on and select “FIND NEW EXHAUST SENSOR”.

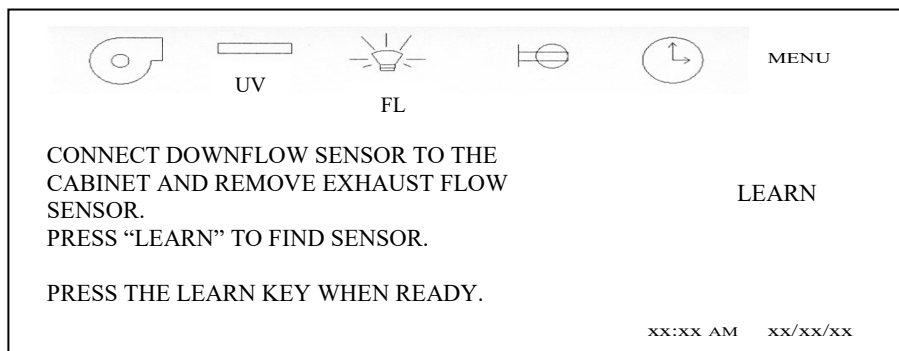

- Press “LEARN” to find sensor. If successful, display will indicate SENSOR FOUND, if not display may indicate SENSOR ALREADY USED or FAILED TO FIND SENSOR. If this is the case, perform MASTER RESET and start process over.
- Once exhaust sensor is found, turn off power to cabinet, reconnect downflow sensor and turn cabinet power back on.
- Once both downflow and exhaust sensors are found proceed immediately to airflow calibration sections. (i.e. calibrate downflow sensor)

#### 8.2.2.4 Night Setback

The optional night setback is used to allow the cabinet to run at a reduced airflow rate to keep the workzone sterile and maintain containment in a static environment. The night setback is calibrated as a percentage of the nominal setpoint and should be adjusted during the certification process to the desired level.

Once the night setback is initiated, the **AIRFLOW ALARMS AND FLUORESCENT LIGHT WILL BE INHIBITED** to prevent cabinet usage. When calibrating the night setback, use the night setback menu below.

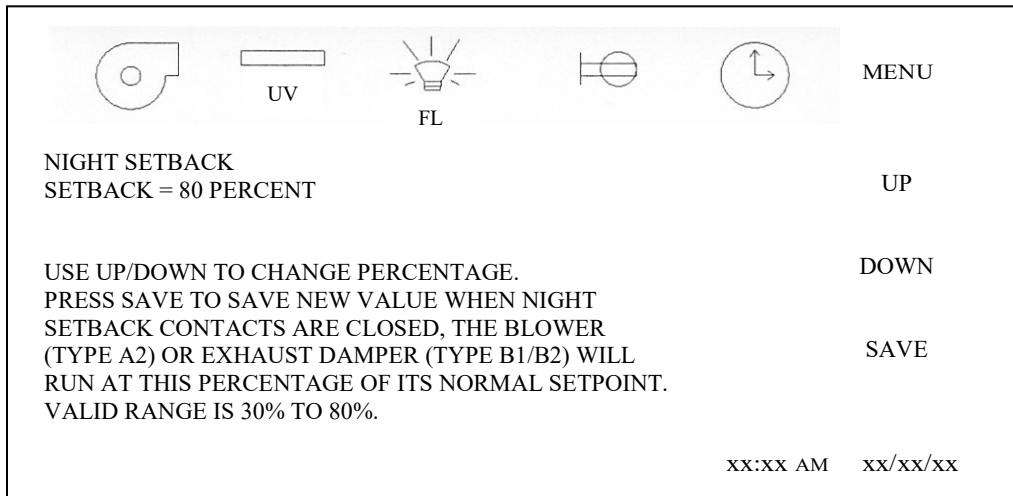

#### 8.2.2.5 Service

The service setup menu allows a QUALIFIED TECHNICIAN to configure, calibrate and obtain functional service data. Each parameter submenu will be described as well as the display will indicate present and/or default conditions as shown.

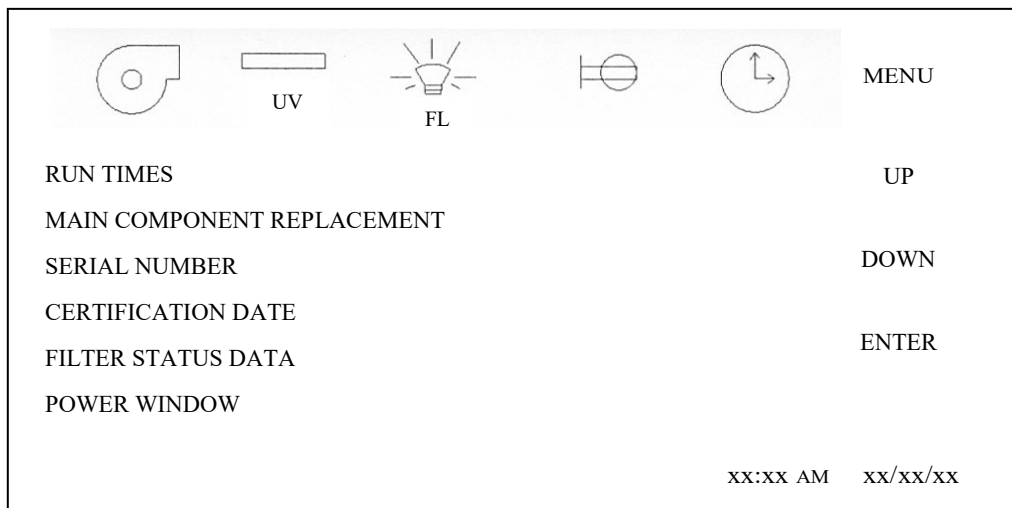



### Run Times

This parameter allows the service technician to view, alter, or reset both UV light and motor blower run timer.

- Select desired run time parameter from menu.

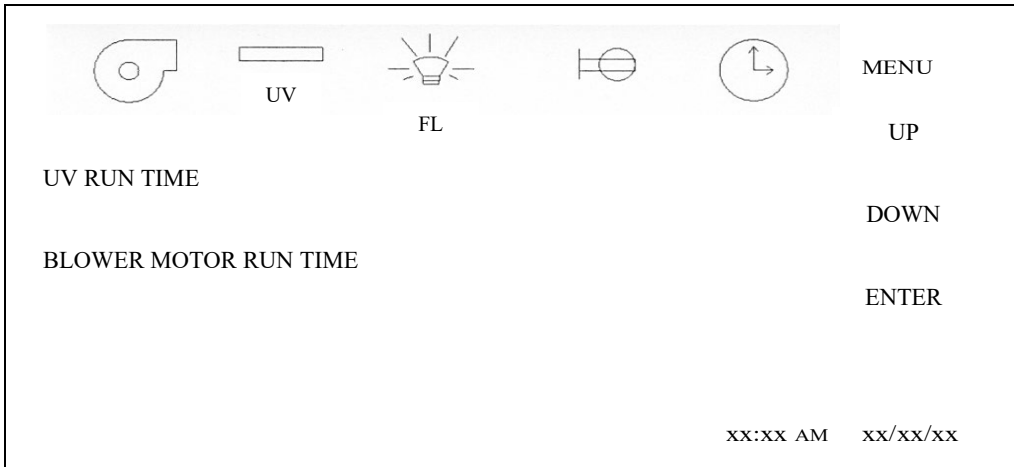

- UV run time.

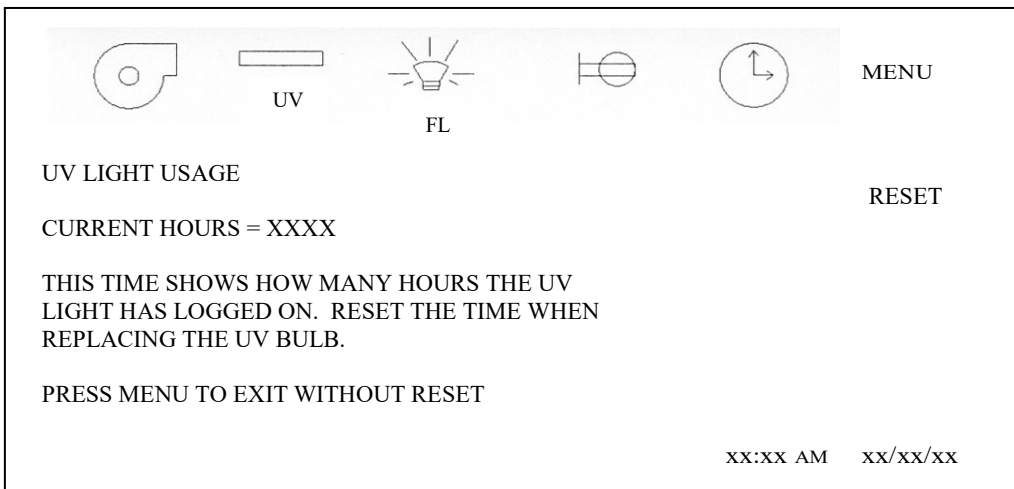

- Motor blower run time.

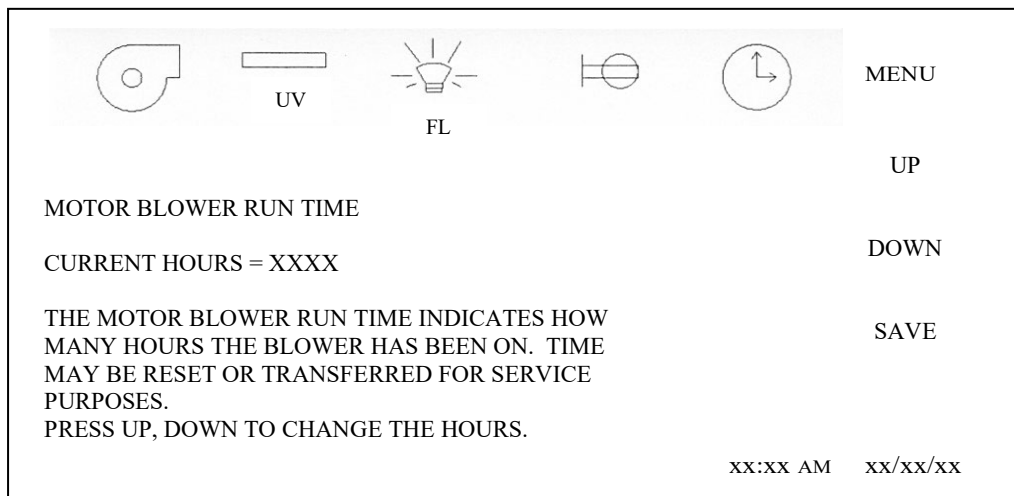

### Main Component Replacement

This parameter allows the service technician to view and update HEPA filters, blower motor, main control board and sensor installation dates.

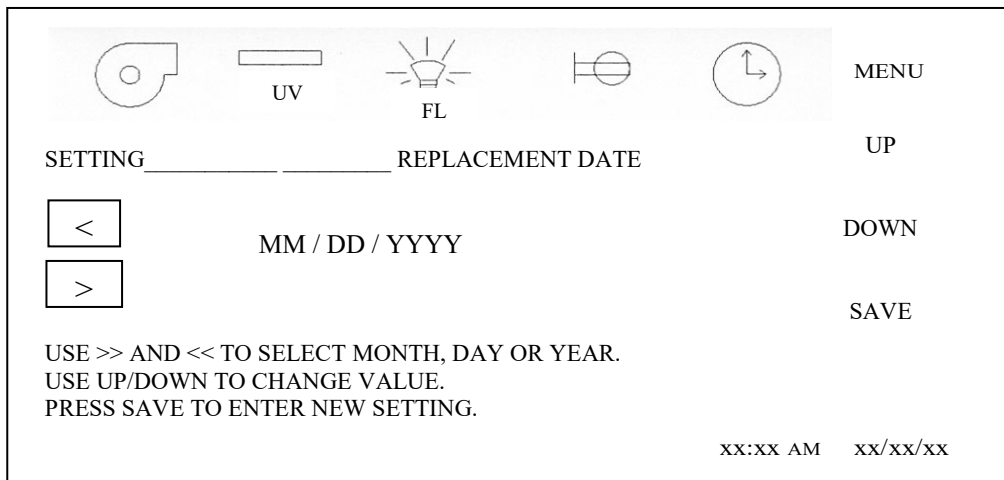
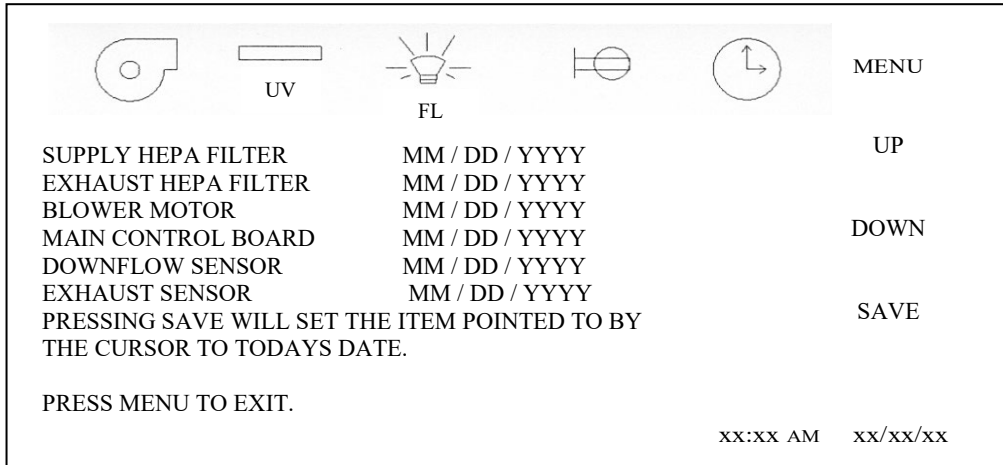

### Serial Number



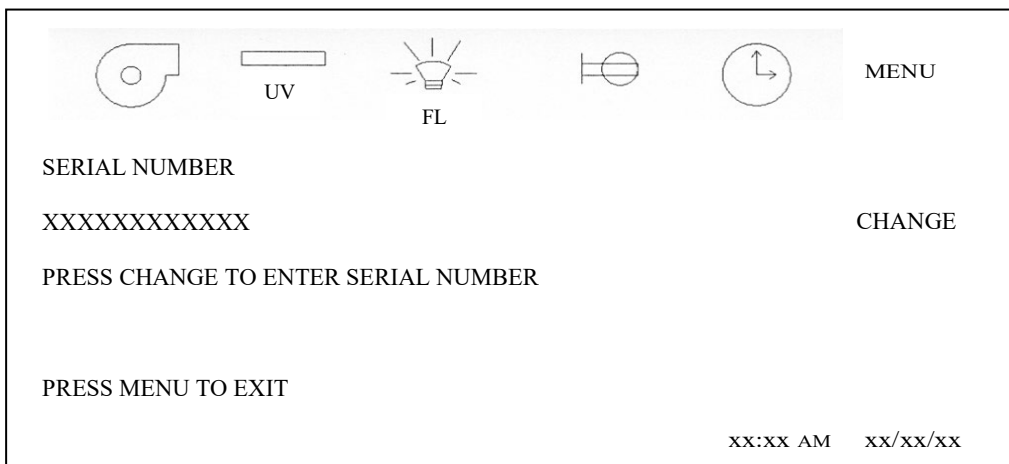

This parameter allows the service technician to view and enter the cabinets' serial number







- Once CHANGE is pressed, a display screen very similar to the password display screen will appear for entry the serial number. Press ENTER to save the serial number.

### Certification Date

This parameter allows the service technician to view and update the current certification date. The certification date also has a feature to indicate an advance notice that re-certification is due. Press DUE to enter into the certification required time period screen. Select desired interval of certification required, i.e. No Reminder, 6, 12, 18, or 24 months. The reminder will appear during the warm up cycle for 10 seconds every time the blower is turned on starting 4 weeks before the due date, then past due.

    	MENU
SETTING CERTIFICATION DATE	
MM / DD / YYYY	DUE
PRESSING SET TO ENTER A CERTIFICATION DATE TO TODAY'S DATE. (MM / DD / YYYY)	SET
PRESS DUE TO SET WHEN NEXT CERTIFICATION WILL BE REQUIRED.	
xx:xx AM	xx/xx/xx

    	MENU
SETTING CERTIFICATION DATE	
<input type="button" value="&gt;&gt;"/>	UP
XX/XX/XXX	
<input type="button" value="&gt;&gt;"/>	DOWN
PRESS >> AND << TO SELECT MONTH, DAY, OR YEAR PRESS UP/DOWN TO CHANGE VALUE. PRESS SAVE TO SAVE NEW SETTING.	SAVE
xx:xx AM	xx/xx/xx

CERTIFICATION REQUIRED TIME PERIOD CURRENT PERIOD = NO REMINDER	MENU
PRESS UP/DOWN TO CHANGE TIME PERIOD. PRESS SAVE TO ENTER NEW TIME PERIOD. THIS SETS THE TIME IN WHICH A NEW CERTIFICATION IS REQUIRED. A REMINDER WILL APPEAR STARTING 4 WEEKS BEFORE THIS TIME EXPIRES FROM THE LAST CERTIFICATION.	UP
	DOWN
	SAVE
xx:xx AM	xx/xx/xx

### Filter Status Data

This parameter allows the service technician to set the filter status data used to predict filter life availability. Filter status is based on maximum RPM minus the starting RPM (entered by technician) then scaled to current RPM to determine filter percentage availability. Starting RPM data may be entered at any time for service purposes.

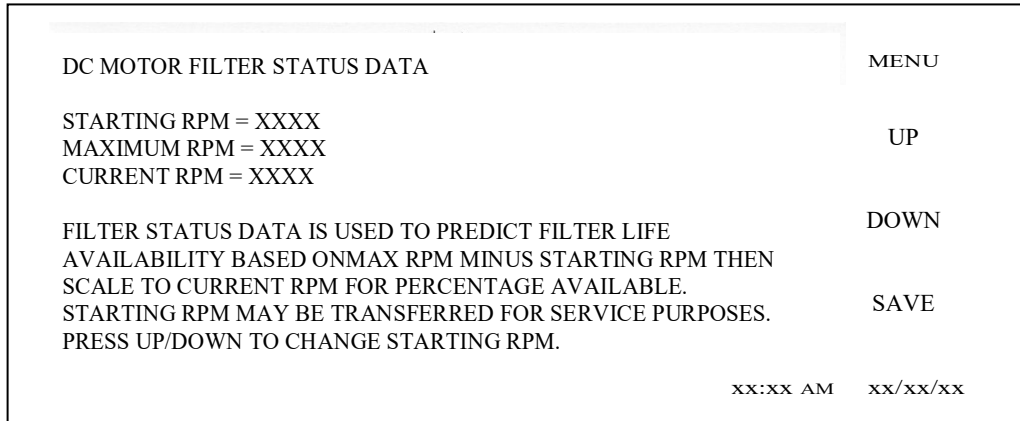

### Power Window

This parameter allows for the power window option to operate. When the power window option is factory installed this parameter will allow the user display menu to indicate the power window up and down icons.

The power window option functions using a 24 Vdc motor and internal feedback encoder to determine window position. The power window also incorporates a safety auto reverse feature to eliminate any pinch hazard.

- Select desired power window parameter from menu.

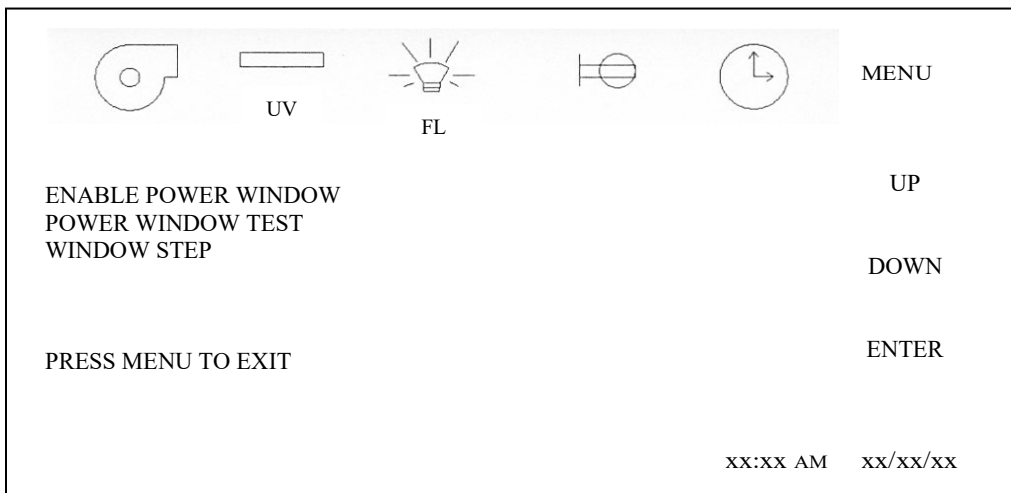

### Enable Power Window

- Select power window option on or off.

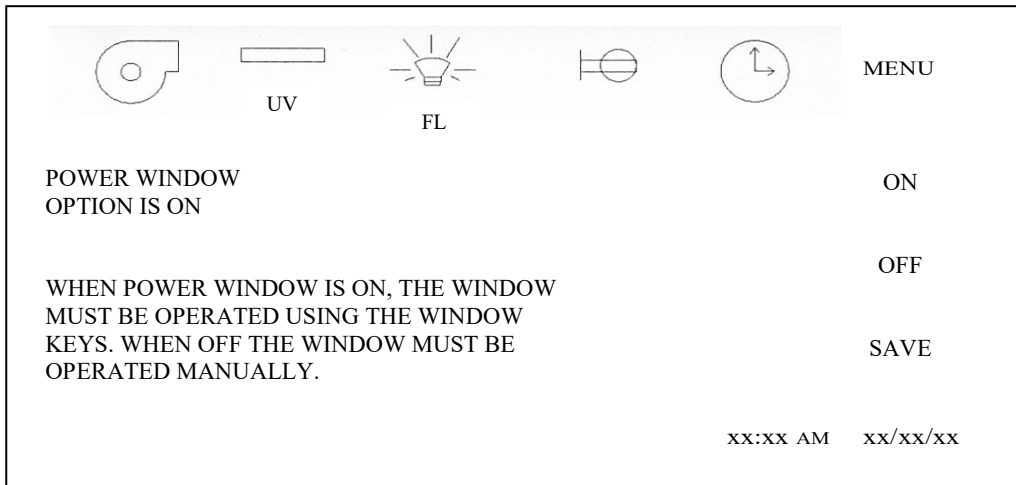

### Power Window Test

- Power window test allows the movement of the power window for all positions including the lowest position, with the armrest removed, used for the decon process.

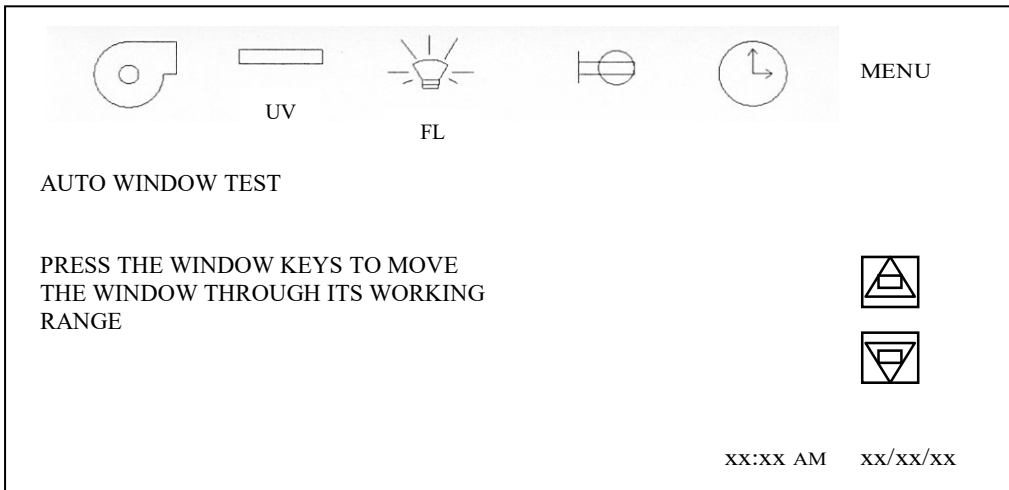

### Window Step

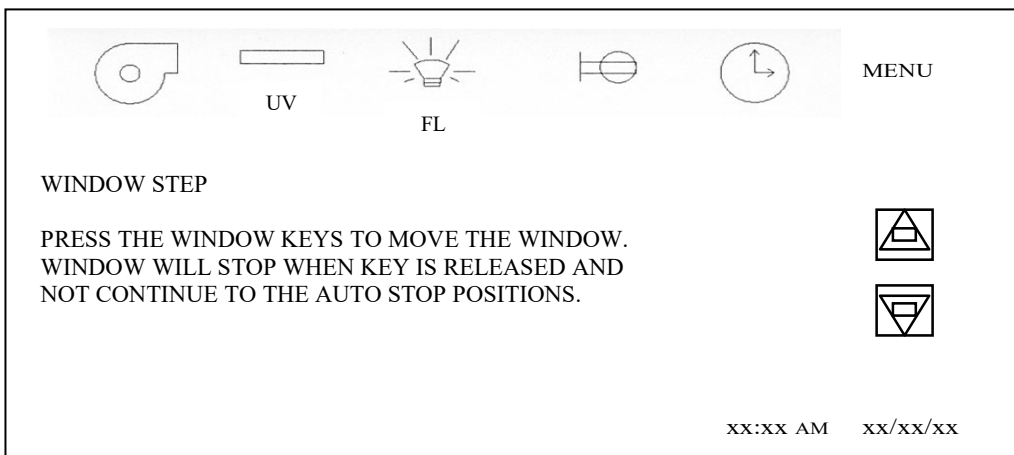

### Power Window Calibration

The power window is calibrated by the micro switch position within the left window glide assembly. To access the micro switches for adjustment, remove the left faring rear access cover via fasteners. Micro switches are then adjustable using a Phillips screwdriver.

Micro switch Position	Micro switch Function	Window Function
Top	Max Window Height	Stops when activated.
Top Middle	Window High Alarm	Continues to travel down for 1/8" (3mm) past switch deactivation.
Bottom Middle	Window Low Alarm	Continues to travel up for 1-7/8" (48mm) past switch deactivation.
Bottom	Window Closed	Stops when deactivates.

### 8.2.2.6 Option Set Up

The option set up menu allows **A QUALIFIED TECHNICIAN** to configure several different optional parameters per the menu below. Each parameter sub-menu will be described as well as the display will the default conditions as shown.

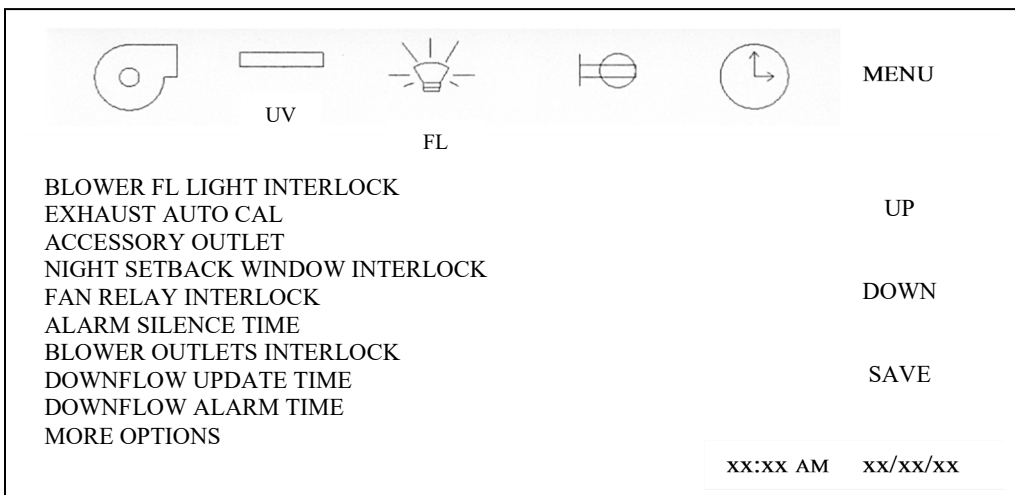
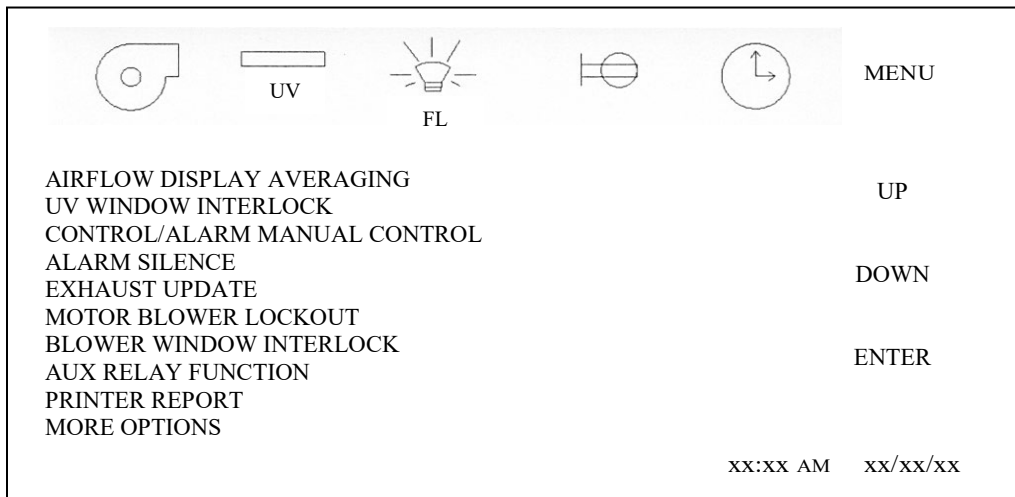

### Airflow Display Averaging

This parameter allows for the selection of the airflow display averaging function to operate. When the airflow averaging is on, the downflow display will always indicate the airflow setpoint 60fpm (0.30m/s) if the airflow is valid and within its alarm limits. The exhaust display will use the exhaust update averaging function.

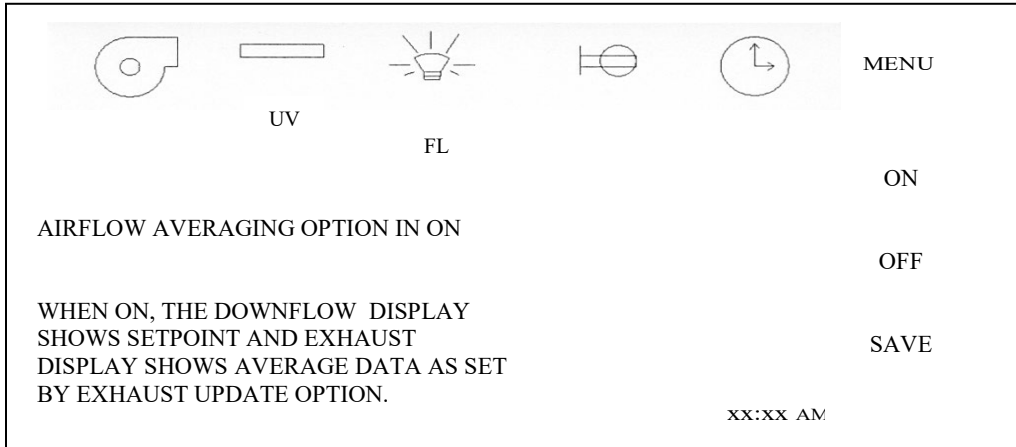

### UV Window Interlock

This parameter allows for the selection of the window closed switch to be interlocked with the UV light option. When the window interlock is on, the window must be closed for the UV light to operate. When the window interlock is off, the UV light can be turned on regardless of the window position.

 **NOTE:** In addition to the **TOUCHLINK** system UV window interlock there is a double redundant UV window interlock relay. To override the UV window interlock for service purposes only, both interlocks must be changed through the **TOUCHLINK** system and shorting the relay connection (see electrical schematic for reference).

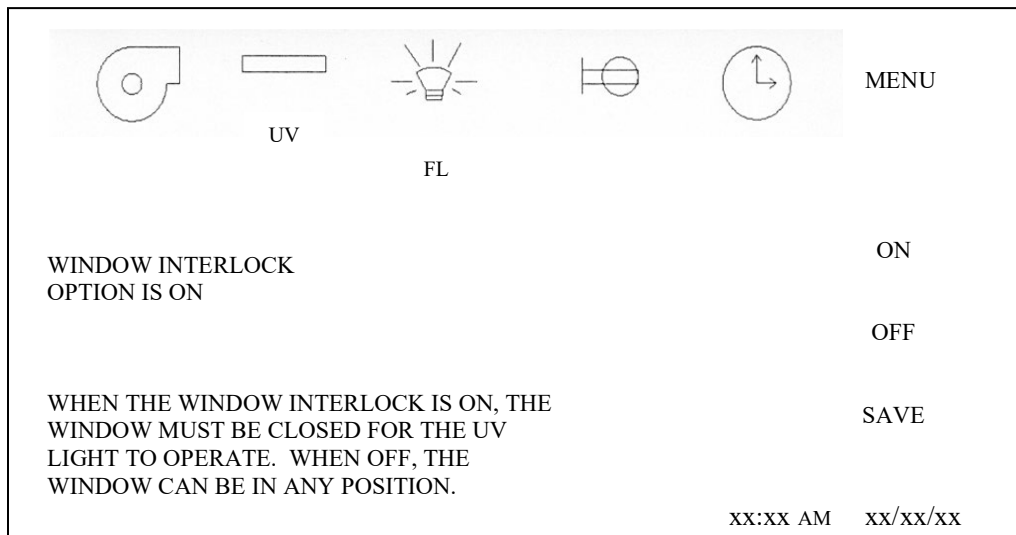

### Control/Alarm Manual Control

This parameter allows **ONLY THE CABINET TECHNICIAN** to run the cabinet in manual mode. This means with no controls or alarms activated. When the manual control is on, the downflow and inflow displays will indicate nominal setpoints. Airflow adjustments can be made in the manual mode by going into airflow calibration and adjusting the blower duty cycle. The blower duty cycle will remain constant in manual mode. The display will also indicate the manual control is activated. When the manual control is off, full automatic control resumes.

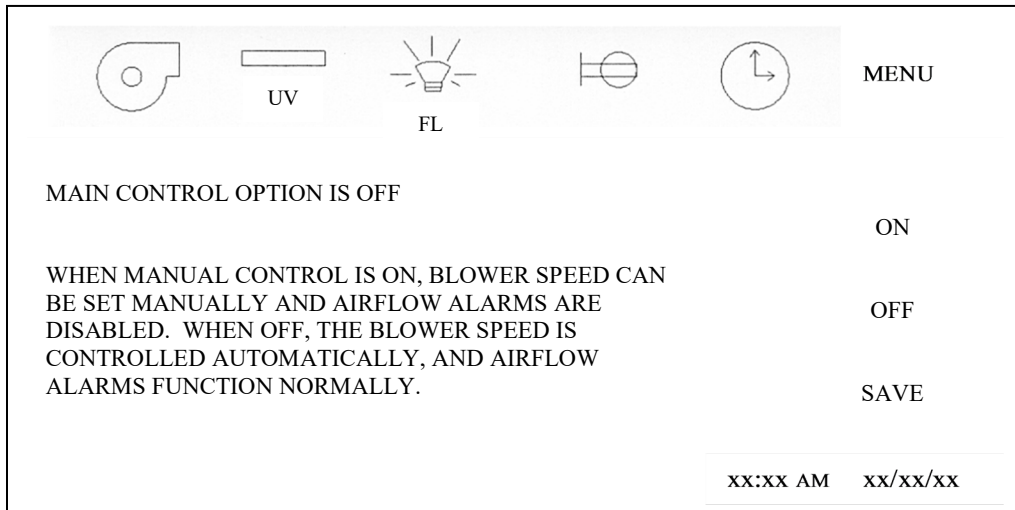

### Alarm Silence

This parameter allows for the selection of the alarm silence key function. When the alarm silence function is on, all current and future alarms will be silenced for the designated alarm silence time (i.e. default time is 15 minutes). When the alarm silence function is off, all current alarms will be silenced for alarm silence time. If a new alarm is present, the audible alarm will again be turned on.

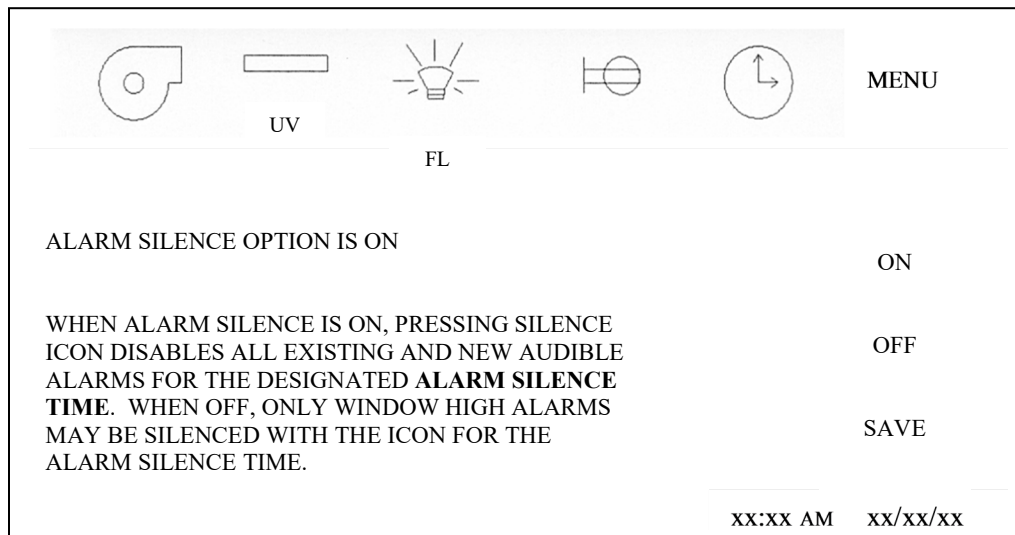



### Exhaust Update

This parameter allows for the selection of time to determine how much exhaust flow data is averaged before being displayed. The time is displayed in seconds with a programmable range from 1 to 60.

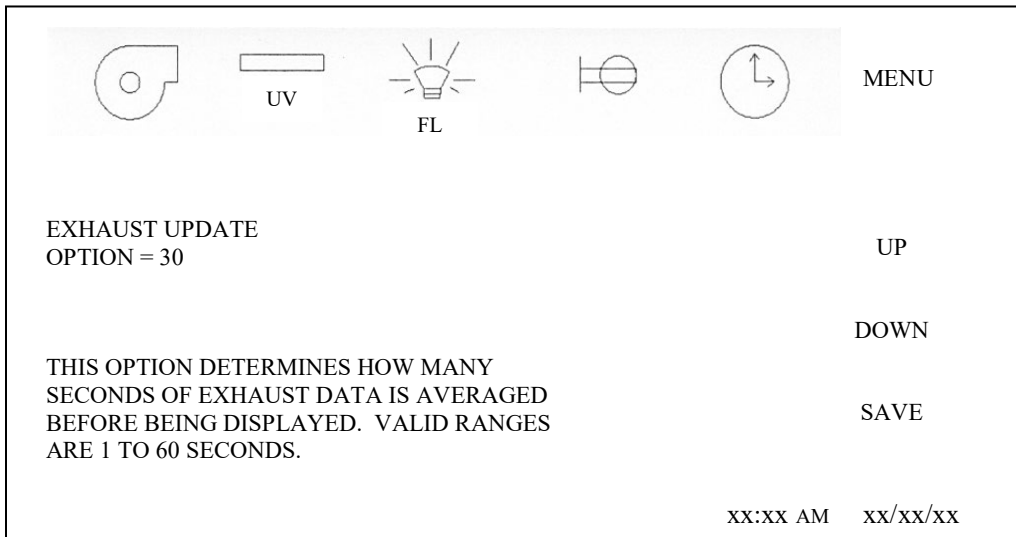

### Motor Blower Lockout

This parameter allows the access to turn the blower on or off to be restricted by the use of a password. When the blower lockout is on, pressing the blower icon will produce a numerical password screen. The default password is "1234" and may be changed using the password menu. When the blower lockout is off, the blower may be turned on and off without restriction.

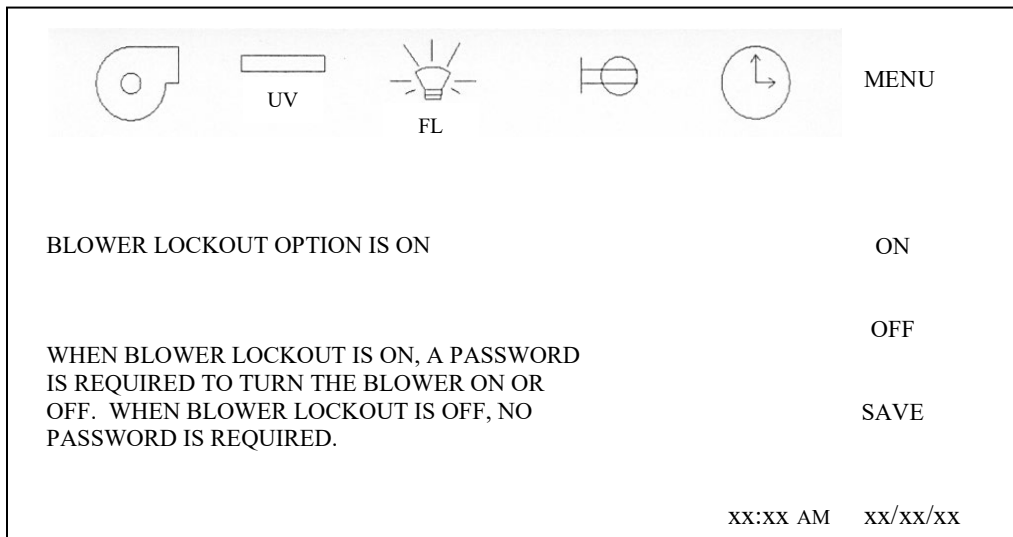

### Blower Window Interlock

This parameter allows for the selection of the window closed switch to be interlocked to the blower. When the blower interlock is on, the blower will turn off when the window is closed. When the blower is off, the blower will continue to run when the window is closed.

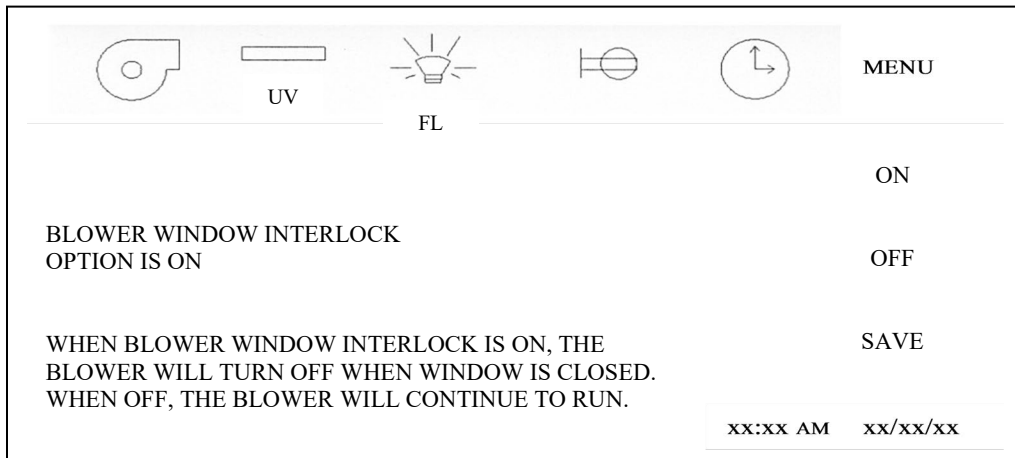

### AUX Relay Function

This parameter allows for the selection of the AUX relay function. When the AUX relay is on, the AUX relay function will be identical to the fan relay. When the AUX relay function is off, the AUX relay function provides delay On/Off option.

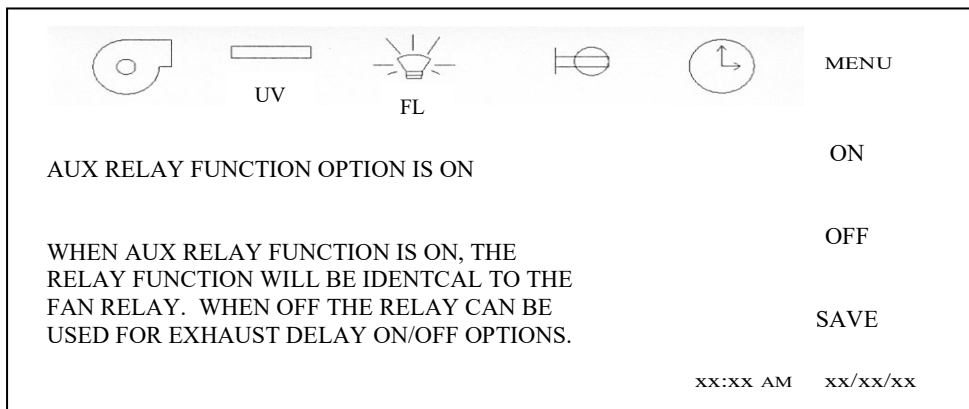

### Printer Report Frequency

This parameter allows for the selection of the frequency of the RS-232 Communication Output. The Communication Output provides communication from the cabinet to a personal computer (HyperTerminal) or printer via RS-232 interconnect standard. RS-232 provides short range (50 feet) simple point-to-point connection with another RS-232 device.





The Communication Interface utilizes 9-bit character frame with eight bits (no parity) and a stop bit (8.N.1) with a constant transmission speed of 57,600 bps for communication.

The connection for the RS-232 output is located on the main control board as a RJ-45 (8-pin) connector (J5).

The following is the pin position for the connector:





- |              |              |
|--------------|--------------|
| 1 - NOT USED | 5 - NOT USED |
| 2 - NOT USED | 6 - NOT USED |
| 3 - GROUND   | 7 - TRANSMIT |
| 4 - NOT USED | 8 - RECEIVE  |

The Communication Output provides airflow readings as shown below. Actual airflows with setpoints (in parentheses) are output.

					MENU
<p>PRINTER REPORT FREQUENCY OPTION SETTING = 0</p>					ON
<p>THIS OPTION DETERMINES HOW OFTEN THE CONTROLLER OUTPUTS THE CURRENT STATUS TO A PRINTER. VALID CHANGES ARE 1 TO 60 MINUTES. SETTING THE FREQUENCY DISABLES THE OUTPUT.</p>					OFF
					SAVE
					xx:xx AM xx/xx/xx

**Blower FL Light Interlock**

This parameter allows for the selection of the fluorescent light option to be interlocked to the blower. When the blower FL light interlock is on, the fluorescent light operation will be interlocked to the blower. When the blower FL light interlock is off, the fluorescent light can be turned on at any time.

					MENU
<p>BLOWER FL LIGHT INTERLOCK OPTION IS OFF</p>					ON
<p>WHEN BLOWER FL LIGHT INTERLOCK IS ON, THE FL LIGHT WILL TURN ON WHEN THE BLOWER IS TURNED ON AND CAN ONLY BE TURNED ON WHEN THE BLOWER IS ON. WHEN OFF, THE FL LIGHT CAN BE TURNED ON AT ANYTIME.</p>					OFF
					SAVE
					xx:xx AM xx/xx/xx

### Exhaust Auto CAL

This parameter allows the Exhaust Auto CAL function to operate. The Exhaust Auto CAL function automatically performs a calibration offset to the setpoint value for the inflow display. The calibration offset is performed at the end of the warm-up cycle, then 1 hour after the warm-up cycle and every 4 hours after that. The Exhaust Auto CAL function is based upon the fact that the cabinet has a common plenum between the supply and exhaust (inflow) airflow. The blower air volume is split between the supply (70%) and the exhaust (30%) airflow. Typically these values being in a common plenum will rise and fall together so if the blower duty cycle or voltage is constant or within tolerance, the cabinet airflows will also be within the acceptable tolerance range and the auto CAL function will occur. If the blower duty cycle or voltage is not within the specified tolerance, the auto CAL function will not occur.

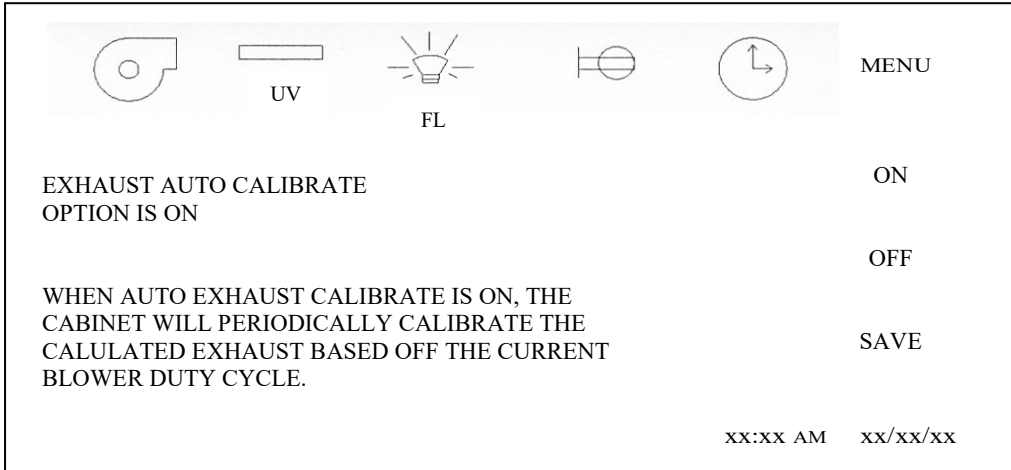

### Accessory Outlet



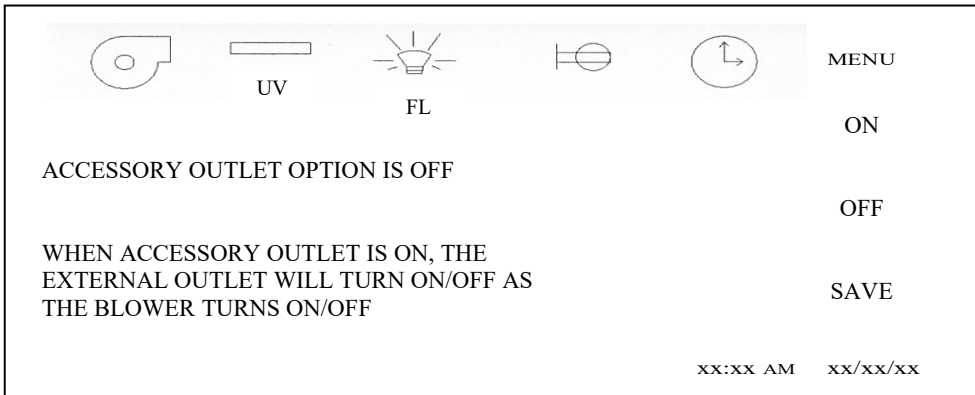

This parameter allows for the selection of the power connection that supplies power to the exhaust decon chamber to be interlocked to the blower. This parameter would only be used in special cases and does not affect operation during an auto decon cycle.



### Night Setback Window Interlock





This parameter allows for the selection of the night setback function to be initiated upon a sliding window closure. Once the sliding window is closed, the fluorescent light will be disabled and the airflow will be reduced to a percentage of the normal setpoint.

 **Note:** Blower window interlock must be turned off to allow the night setback function to operate.

					MENU
NIGHT SETBACK WINDOW INTERLOCK OPTION IS OFF					ON
WHEN NIGHT SETBACK WINDOW INTERLOCK IS ON, CLOSING THE WINDOW WILL INITIATE A NIGHT SETBACK AND THE BLOWER WILL RUN A LOWER PERCENTAGE OF THE NORMAL SETPOINT. FLUORESCENT LIGHT WILL ALSO TURN OFF.					OFF
					SAVE
xx:xx AM xx/xx/xx					





### Fan Relay Interlock

This parameter allows for the selection of the fan relay interlock operation. When the fans relay interlock is on, and the blower switch is pending or blue, the fan relay will be off or not energized. If the fan relay interlock is off and the blower switch is pending or blue, the fan relay will be on or energized. In either case the fan relay will be on when the blower switch is on or green and off when the blower switch is off or not colored.

					MENU
FAN RELAY INTERLOCK IS OFF					ON
WHEN THE FAN RELAY INTERLOCK IS ON AND THE BLOWER SWITCH IS PENDING OR BLUE, THE FAN RELAY WILL BE OFF. IF THE FAN INTERLOCK RELAY IS OFF AND THE BLOWER SWITCH IS PENDING OR BLUE, THE FAN RELAY WILL BE ON.					OFF
					ENTER
xx:xx AM xx/xx/xx					

### Alarm Silence Time

This parameter allows for the selection of time to determine how long the audible alarm shall be silenced. The time is displayed in minutes with a programmable range of 1 to 60.

					MENU
ALARM SILENCE TIME OPTION SETTING = 15					ON
THIS OPTION DETERMINES HOW MANY MINUTES THE AUDIBLE ALARM WILL BE SILENCED WHEN SILENCE IS PRESSED.					OFF
VALID RANGES ARE 1 - 60 MINUTES					ENTER
xx:xx AM xx/xx/xx					

### Blower Outlet Interlock

This parameter allows for the selection of the outlets (out 1, out 2) option to be interlocked to the blower. When the blower outlet interlock is on, the outlets (out 1, out 2) operation will be interlocked to the blower. When the blower outlet interlock is off, the outlets (out 1, out 2) can be turned on at any time.

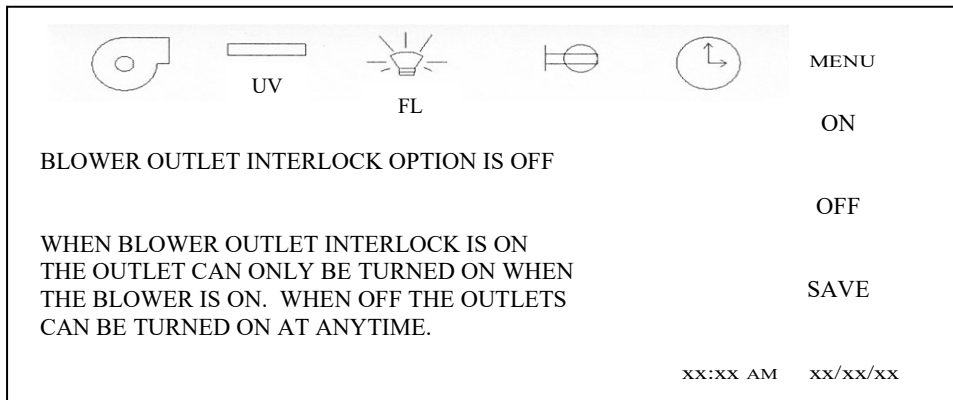

### Downflow Update Time

This procedure allows for the selection of time to determine how much downflow data is averaged before being displayed. The time is displayed in seconds with a programmable range from 4 to 12 seconds.

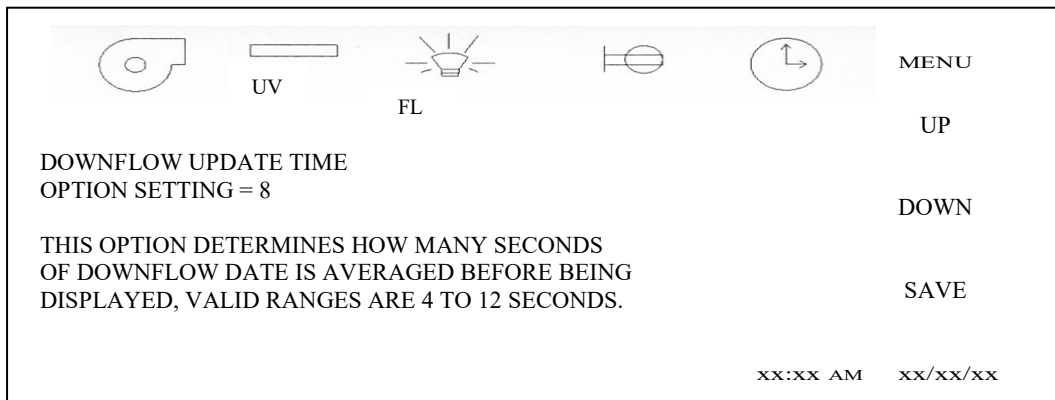

### Downflow Alarm Time

This parameter allows for the selection of time to determine how many continuous seconds of an alarm condition occurs before activating an audible and visual alarm. This time is displayed in seconds with a programmable range from 2 to 12 seconds.

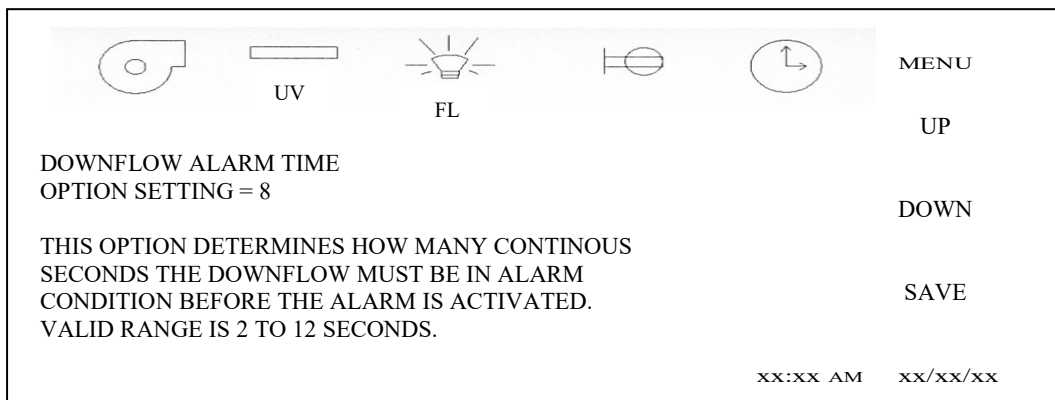

### 8.2.2.7 Diagnostics

The diagnostics menu allows **A QUALIFIED TECHNICIAN** to exercise the control system's inputs and outputs. Each of these has its own menu screen to exercise the control system. Select menu screen as desired.

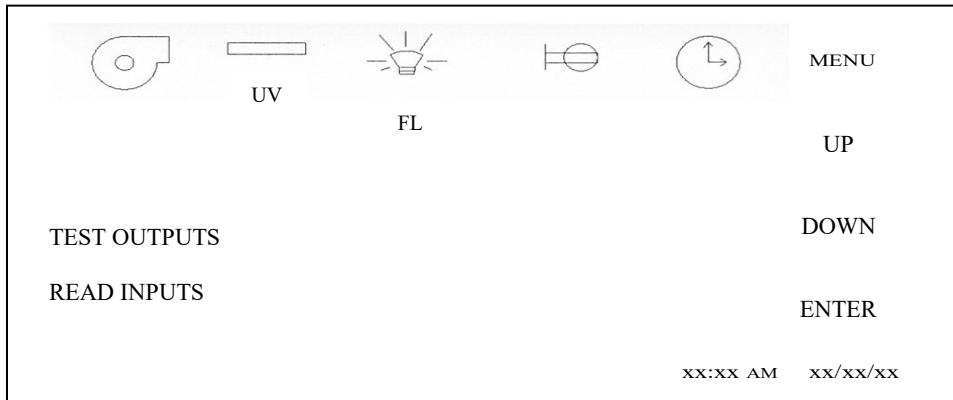

#### Test Outputs

Test outputs allow a service technician to exercise these output functions.

Pressing TOGGLE will turn on and off the functions.

Press UP and DOWN to select the test output desired.

Use the display icons to turn on/off each function of blower, UV light, fluorescent light, outlet and optional power window if installed.

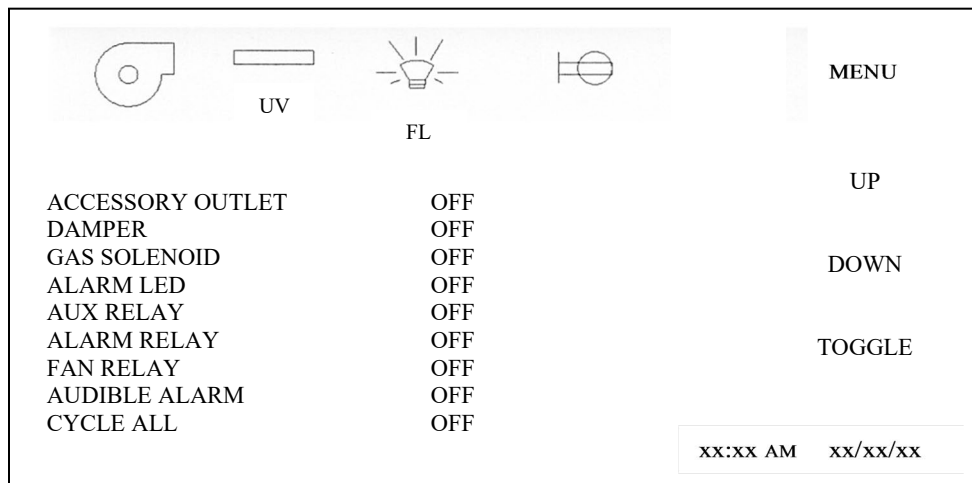

## Read Inputs

Read inputs all a service technician to exercise or check these input functions. The inputs may be checked by altering the state of the input function (i.e. sliding window position) and monitoring the change on the display.

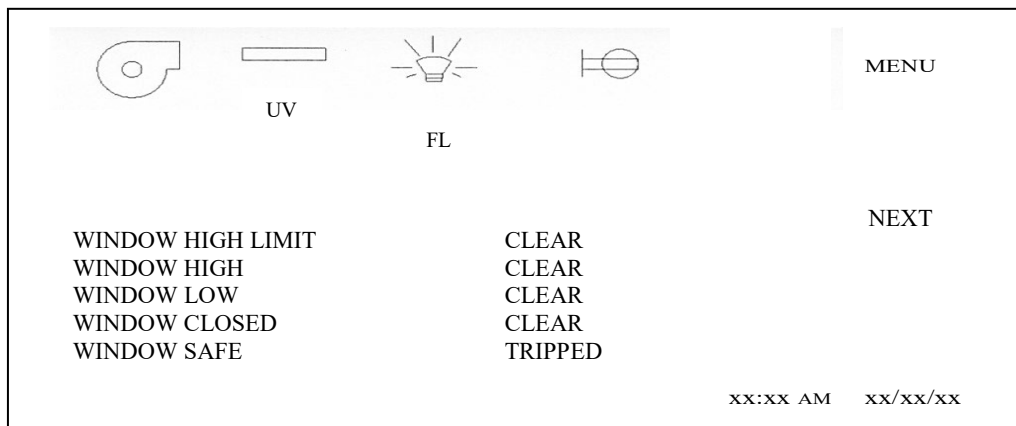
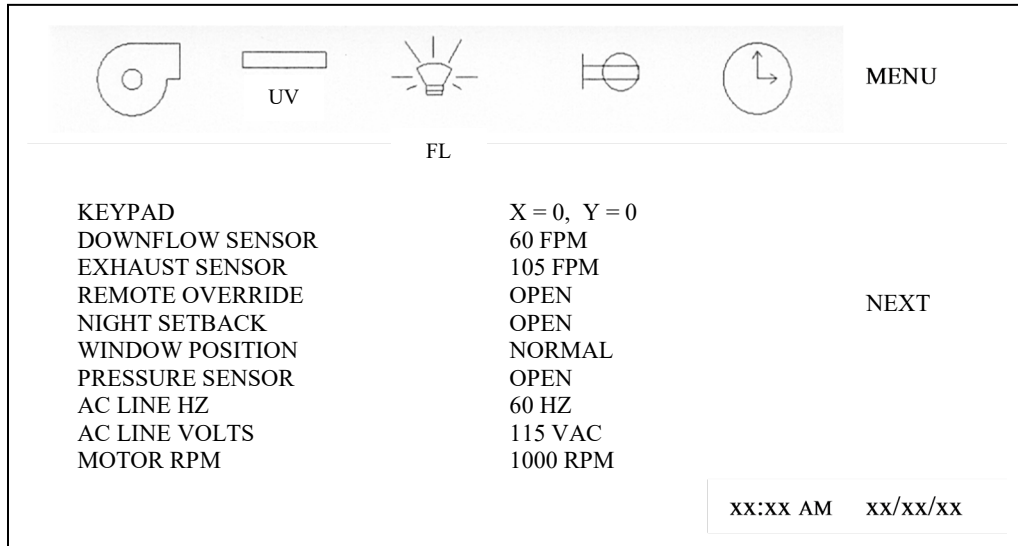

### 8.3 Airflow Sensor Performance Verification

The individual airflow sensors can be routinely checked during calibration or in diagnostics to assure they are reading and active within the range of use (0 to 200 fpm). The airflow sensors can also be checked in the run mode through performance verification, for responsiveness to changing airflow conditions.

#### 8.3.1 Run Mode

To check the airflow sensor in run mode, first allow the cabinet to operate normally for a minimum of 5 minutes. Then, place a rolled piece of paper over the downflow sensor in the workzone and leave the paper on the sensor for at least 2 minutes and then remove. This action will cause the cabinet to go into a downflow alarm condition. The exhaust airflow reading should increase during this test. However, the downflow reading should go down to zero on the display "0". There should also be a noticeable increase in motor/blower noise. It would also be recommended to monitor motor/blower voltage during the test. The motor/blower voltage should be monitored from when the cabinet is running normally. During the test, when the downflow sensor is covered, the motor/blower voltage should be steadily increasing too slightly under line voltage. When the downflow sensor is uncovered, the motor/blower voltage should decrease and airflow readings should be within the calibration range.

If the motor/blower voltage does not change, an airflow sensor problem could exist. Please consult with NuAire Technical Service.



## 9.0 Remote Contacts

The NU-581 has several contact closures for remote sensing of various functions.

### 9.1 Fan Relay

The fan relay contacts are dual normally open contact closure outputs which are activated whenever the blower is turned on. Contact ratings are 250 VAC maximum at 2 Amps.

### 9.2 Alarm Relay

The alarm relay contacts are dual normally open contact closure outputs which are activated whenever an airflow alarm condition occurs. An airflow alarm condition will occur if either airflow sensor detects 5 consecutive 2 second airflow readings above or below the alarm limits. Contact ratings are 250 VAC maximum at 2 Amps.

### 9.3 AUX Relay

The AUX relay contacts are common, normally open and normally closed contact closure outputs which are activated whenever the blower is turned on. However, the AUX relay does have some conditional logic programmed. The relay will activate whenever the blower is turned on and stay on unless after 5 minutes there is a low exhaust alarm, then the relay will deactivate. If exhaust is sufficient, the relay will stay active. If the blower is then turned off, the relay will stay active for one minute then deactivate. The AUX relay may also be selected to operate the same as the fan relay. Reference the AUX relay function in the option menu. Contact ratings are 250 VAC maximum at 2 Amps.

### 9.4 Remote Override

The remote override contacts are (no power) **shorting contacts only**, which when closed, indicates to the control system to shut down the cabinet. The blower would be turned off, an audible alarm would be turned on for several seconds and the clock display will indicate "RM.OV".

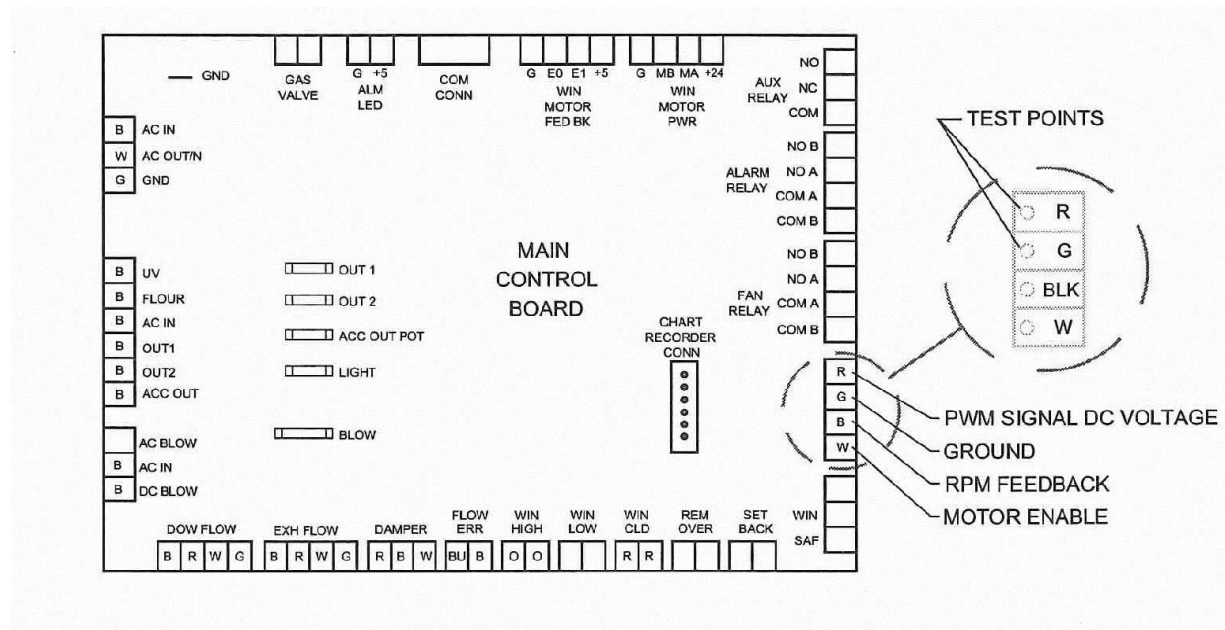

## 10.0 Optional Equipment

### 10.1 Ultraviolet Light



**Ultraviolet light will injure your eyes. Avoid direct viewing at all times. Personnel should not be present when ultraviolet lamp is on**

#### 10.1.1 Overview

The germicidal ultraviolet is primarily intended for the destruction of bacteria and other microorganisms in the air or on directly exposed surfaces. Approximately 95% of the ultraviolet radiations from germicidal tubes are in the 253.7 nanometer region. This is a region in the ultraviolet spectrum which is near the peak of germicidal effectiveness. The exposure necessary to kill bacteria is the product of time and intensity. High intensities for a short period of time, or low intensities for a longer period are fundamentally equal in lethal dosage on bacteria (disregarding the life cycle of bacteria). The intensity of light falling on a given area is governed by the inverse law; that is the killing intensity decreases as the distance increases from the tube.

**The germicidal tube is placed in the cabinet to provide an average intensity of 100 microwatts per centimeter (for a new tube) falling on a horizontal plane defined by the bottom of the work surface. The minimum requirement per paragraph 5.12 of NSF Standard 49 is 40 microwatts per square centimeter (ref. NSF Std. #49, June, 1976).**

Since ultraviolet rays will not penetrate ordinary glass, it is recommended that the sliding window be closed while the ultraviolet light is on within the cabinet; or that personnel leave the cabinet face area.

#### 10.1.2 Operation

The operation of the ultraviolet light is accomplished by closing the sliding window and pressing the UV switch located on the front panel. The sliding window is interlocked to the ultraviolet light so, when the sliding window is raised, the ultraviolet light will turn off. If operational time duration is known, the timer can be used in conjunction with the ultraviolet light to time out the ultraviolet light operation. This can be accomplished by first turning on the ultraviolet light. Then, set the timer to the desired length of ultraviolet light operation time. Upon timer expiration, the ultraviolet light will turn off.

#### 10.1.3 Precaution

The rays from germicidal tubes may cause a painful but temporary irritation of the eyes and reddening of the skin, if of sufficiently high intensity, or if exposure covers a prolonged period of time. For this reason, one should avoid direct eye and skin exposure to ultraviolet light. If exposure cannot be avoided, it is necessary for personnel to wear eye goggles or face shields, and long sleeve gowns with rubber gloves.

Since ultraviolet rays will not penetrate ordinary glass, it is recommended that the sliding window be closed while the ultraviolet light is on within the cabinet; or that personnel leave the cabinet face area.

#### 10.1.4 Maintenance

The output of an ultraviolet light deteriorates with burning age. The useful life of the light is approximately 7000 hours under specific test conditions.



**NOTE:** Before testing with lamp off, the light may be cleaned with a lint-free cloth dampened with alcohol or ammonia and water.

It is recommended that either a time schedule be established or the tube's output be measured periodically and the tube replaced when its output falls below 40 microwatts per square centimeter or exceeds 7000 hours of operation. Lights should be allowed to operate approximately 5 to 10 minutes (longer when the light is in low temperatures) to warm up sufficiently before reading the output with a meter.

### Energies Required to Destroy Some Microorganisms by Ultraviolet Radiation's (e)

Mold Spores	Microwatt seconds per cm/2	Protozoa	Microwatt seconds per cm/2
Penicillium roqueforti	26,400	Paramecium	200,000(a)
Penicillium expansum	22,000		
Penicillium digitatum	88,000	<b>Nematode Eggs</b>	40,000(b)
Aspergillus glaucus	88,000		
Aspergillus flavus	99,000	<b>Algae</b>	22,000(c)
Aspergillus niger	330,000		
Rhizopus nigricans	220,000	<b>Virus</b>	
Mucor racemosus A	35,200	Bacteriophage (E. Coli)	6,600
Mucor racemosus B	35,200	Tobacco Mosaic	440,000
Oospora lactis	11,000	Influenza	3,400(d)
<b>Yeasts</b>			
Saccharomyces	13,200		
ellipsoideus	17,600		
Saccharomyces cerevisiae	13,200		
Brewers' yeast	6,600		
Baker's yeast	8,800		
Common yeast cake	13,200		
<b>Bacteria</b>			
Streptococcus lactis	8,800		
Strep. hemolyticus (alpha type)	5,500		
Staphylococcus aureus	6,600		
Staphylococcus albus	5,720		
Micrococcus sphaeroides	15,400		
Sarcina lutea	26,400		
Pseudomonas fluorescens	7,040		
Escherichia coli	7,040		
Proteus vulgaris	7,480		
Serratia marcescens	6,160		
Bacillus subtilis	11,000		
Bacillus subtilis spores	22,000		
Spirillum rubrum	6,160		

#### References:

- (a) Luckiesh, Matthew (1946) Application of Germicidal, Ethymal and Infrared Energy, D. Van Nostrand o., New York, New York, pp 253
- (b) Hollaender (1942) Aerobiology, A.A.A.S. (for 90% inactivation), pp 162
- (c) Ellis, C. and Wells, O.O. (1941) The Chemical Action of Ultraviolet Rays, Reinhold Publishing Corp., pp. 713-714
- (d) Hollaender, A., Oliphant, J.W. (1944) The inactivation effect of monochromatic ultraviolet. Radiation on Influenza Virus (for 90% inactivation) Jour. of Bact. 48, pp. 447-454
- (e) This table, "Energies Required to Destroy Some Microorganisms by Ultraviolet Radiation's" comes from Westinghouse brochure entitled - "Westinghouse Sterilamp Germicidal Ultraviolet Tubes"

## 11.0 Electrical/Environmental Requirements

### 11.1 Electrical (Supply Voltage Fluctuations Not to Exceed +/- 10%)

*NU-581-400	115 VAC,	60 Hz,	1 Phase,	14 Amps
*NU-581-500	115 VAC,	60 Hz,	1 Phase,	14 Amps
*NU-581-600	115 VAC,	60 Hz,	1 Phase,	14 Amps

\*UL/UL-C Listed

### 11.2 Operational Performance (for indoor use only)

Environment Temperature Range:	60°F-85°F (15°C - 30°C)
Environment Humidity:	Maximum relative humidity 80% for temperatures up to 31°C decreasing linearly to 50% relative humidity at 40°C
Environment Altitude:	6562 Feet (2000 meters) maximum

### 11.3 Light Exposure

Standard Fluorescent Lighting @ 150 ft. candles (1614 LUX) maximum intensity.

### 11.4 Installation Category: 2.0

Installation category (overvoltage category) defines the level of transient overvoltage which the instrument is designed to withstand safely. It depends on the nature of the electricity supply and its overvoltage protection means. For example, in CAT II, which is the category used for instruments in installations supplied from a supply comparable to public mains such as hospital and research laboratories and most industrial laboratories, the expected transient overvoltage is 2500 V for a 230 V supply and 1500 V for a 120 V supply.

### 11.5 Pollution Degree: 2.0

Pollution degree describes the amount of conductive pollution present in the operating environment. Pollution degree 2 assumes that normally only non-conductive pollution such as dust occurs with the exception of occasional conductivity caused by condensation.

### 11.6 Chemical Exposure

Chemical exposure should be limited to antibacterial surface disinfectants used for cleaning and disinfecting. **USE OF CHLORINATED OR HALOGEN MATERIALS IN THE CABINET MAY DAMAGE STAINLESS STEEL.** Equipment decontamination can be accomplished by non-condensing gas or vapor Paraformaldehyde, Hydrogen Peroxide or Chlorine Oxide following NSF/ANSI 49, Annex G.

### 11.7 EMC Performance (classified for light industrial)

Emissions:	EN61326
Immunity:	EN61326



Class A equipment is intended for use in an industrial environment. In the documentation for the user, a statement shall be included drawing attention to the fact that there may be potential difficulties in ensuring electromagnetic compatibility in other environments, due to conducted as well as radiated disturbances.

## 12.0 Disposal and Recycle

Cabinets that are no longer in use and are ready for disposal contain reusable materials. ALL components with the exception of the HEPA filters may be disposed and/or recycled after they are known to be properly disinfected.

 **NOTE:** Follow all local, state and federal guidelines for disposal of HEPA filter solid waste.



BIOHAZARD



CHEMICAL HAZARD



**Prior to any disassembly for disposal the cabinet must be decontaminated.**



RECYCLE



LEAD FREE

### Component

Main Cabinet  
 Base Cabinet  
 Front Grill  
 Worksurface  
 Window Faring  
 Window Glides  
 Window  
 Window Frame  
 Front Service Panel  
 Front Decorative Panel  
 Control Center  
 Supply Diffuser  
 Primary Prefilter HEPA Filter Frame  
 Secondary HEPA Filter Frames  
 Hepex Bag  
 Blower Wheel & Housing  
 Motor  
 Printed Wiring Assembly  
 Wire  
 Ballasts  
 Armrest  
 Connectors  
 Hardware

### Material

Stainless Steel  
 Painted Steel  
 Stainless Steel  
 Stainless Steel  
 Stainless Steel  
 HDPE  
 Safety Glass  
 Stainless Steel  
 Painted Steel  
 Painted Steel  
 Painted Steel  
 Aluminum  
 PVC  
 Aluminum  
 PVC  
 Steel  
 Various Steel  
 Lead Free Electronic  
 PVC Coated Copper  
 Various Steel, Electronic  
 PVC  
 Nylon  
 Stainless Steel and Steel

 **Note:** Material type can be verified with use of a magnet with stainless and aluminum being non-magnetic.

REV	ECO	ADDED	DESCRIPTION	DATE	DRFT	CHKD
D	13427		MODEL	6/28/2017	TH	BP

CONTROL CENTER REMOVAL PROCEDURE

**CONTROL CENTER REMOVAL PROCEDURE**

**CAUTION**  
DISCONNECT ALL ELECTRICAL SERVICE TO UNIT BEFORE STARTING PROCEDURE

- 1A.) REMOVE (2) #8-32 SCREWS FROM TOP OF CONTROL CENTER AND GENTLY LET CONTROL CENTER OPEN ON SAFETY STRAPS.
- 2A.) REMOVE MINIHELIC GAUGE HOSE (IF PRESENT) (HOSE CLAMP/MAG GAUGE).
- 3A.) DISCONNECT ELECTRICAL CONNECTORS AND CABLE CLAMPS SO THEY ARE LOOSE TO THE MAIN CABINET (BOTH SIDES).
- 4A.) LOOSEN NUT (HINGE STOP) AND MOVE METAL TAB 90° (IF PRESENT)
- 5A.) REMOVE A 1/4-20 NUT FROM CONTROL CENTER HOLDING THE SAFETY STRAP (BOTH ENDS)
- 6A.) SLIDE CONTROL CENTER TO LEFT, OR LIFT UP, UNTIL FREE
- 7A.) TO ATTACH CONTROL CENTER REVERSE THE ABOVE STEPS.

**FRONT DECORATIVE PANEL REMOVAL PROCEDURE**

- 1A.) REMOVE (2) #8-32 SCREWS FROM TOP OF CONTROL CENTER AND GENTLY LET CONTROL CENTER OPEN ON SAFETY STRAPS.
- 1B.) REMOVE (3) NUTS OR SCREWS FROM TOP EDGE OF PANEL
- 2B.) REMOVE (6) KNURLED SCREWS FROM FRONT OF PANEL, IF PRESENT.
- 3B.) TO ATTACH FRONT DECORATIVE PANEL REVERSE THE ABOVE STEPS.

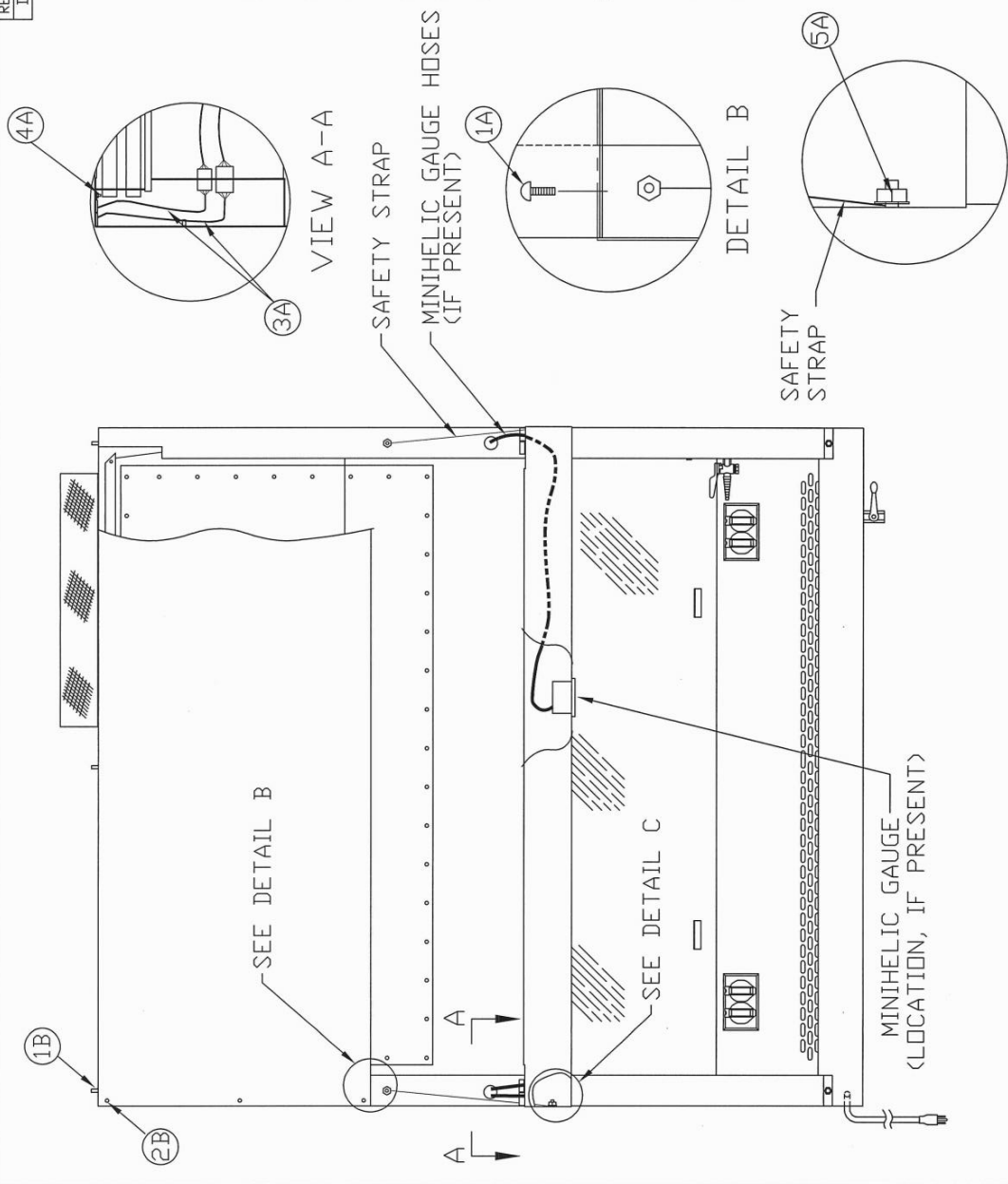

ORIGINAL	
NU-400-500 SERIES CONTROL CENTER & FRONT DECORATIVE PANEL	
DRFTM CV   2/16/07	CHKD BP   SHEET 1 OF 1
DRAWING NUMBER	BCD-11817
	D

REV	ECO	DESCRIPTION	DATE	DRFT	CHKD
D	13427	ADDED NU-581 MODEL	6/28/2017	TH	BP

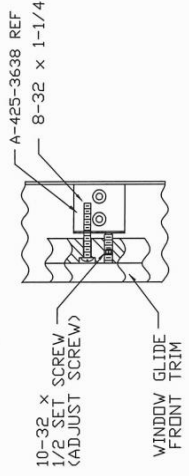

DETAIL A

WINDOW GLIDE ADJUSTMENT

THE WINDOW GLIDES HAVE ADJUSTMENTS THAT ARE LOCATED AT THE CIRCLED POSITIONS 1 THRU 4. TO ACCESS POSITIONS 1 AND 2, REMOVAL OF THE FRONT DECORATIVE PANEL IS NECESSARY. IF THE WINDOW IS TOO LOOSE AT ANY OF THE FOUR POSITIONS LOOSEN THE PHILLIPS HEAD TENSION SCREW AND TURN THE ALLEN HEAD SET SCREW CLOCKWISE A FULL TURN OR UNTIL YOU ACHIEVE THE POSITION THAT IS MOST COMFORTABLE FOR THE WINDOW TO SLIDE. THEN RETIGHTEN THE TENSION SCREW. TURN ADJUST SCREW COUNTERCLOCKWISE IF THE WINDOW IS TOO TIGHT.

- TOOLS REQUIRED:
- 1) 3/32" ALLEN WRENCH
  - 2) PHILLIPS SCREW DRIVER

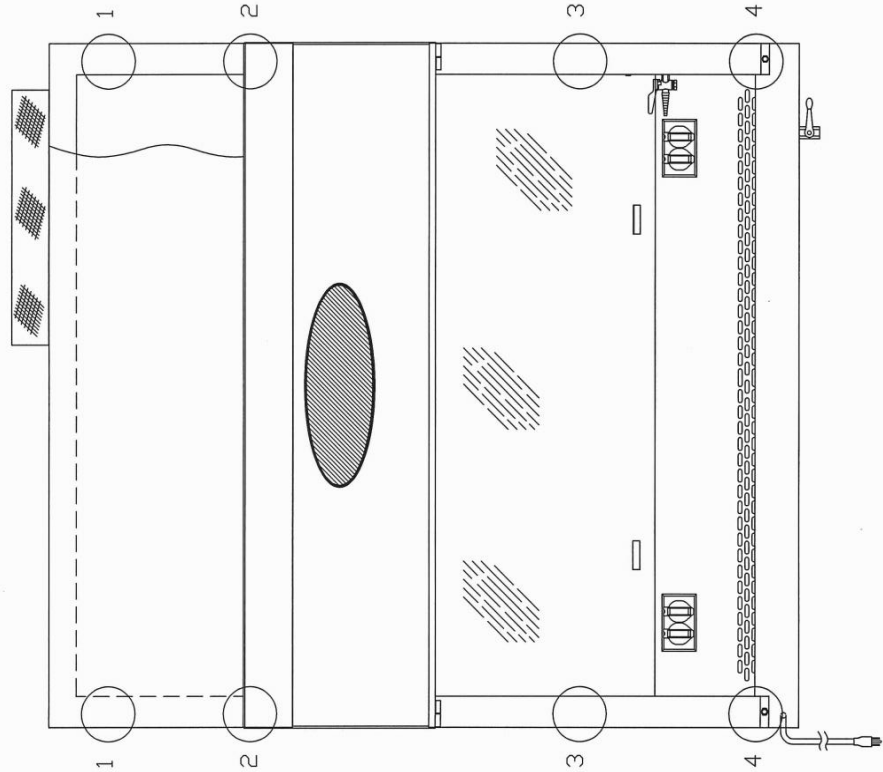

		ORIGINAL
NU-475/477/480/481/581/677 SLIDING WINDOW ASSY & ADJUSTMENT		
DF1M	LS	11/06/06
CHKD	BP	SHEET 1 OF 1
DRAWING NUMBER	BCD-11686	
		D

REV	ECO	DESCRIPTION	DATE	DFTM	CHKD
C	13427	ADDED NU-581	6/28/2017	TH	BP

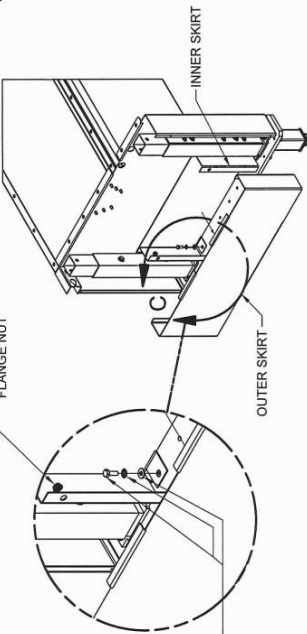

FIG. 1

BASE ADJUSTMENT PROCEDURE.

1. REMOVE (6) 8-32 SCREWS SECURING THE OUTER PANEL TO CABINET BASE. (FIG. 1)
2. REMOVE (2) SERRATED FLANGE NUTS AND OUTER SKIRT. (FIG. 2)
3. REMOVE 1/4-20 HARDWARE FROM BASE SECURING THE INNER SKIRT AND REMOVE THE INNER SKIRT (FIG. 2)
4. SUPPORT THE BOTTOM OF CABINET (FIG.3) AND REMOVE 3/8-16 BOLTS (2 PER LEG) (FIG. 4).

5. RAISE CABINET TO DESIRED HEIGHT AND REVERSE PROCEDURE.

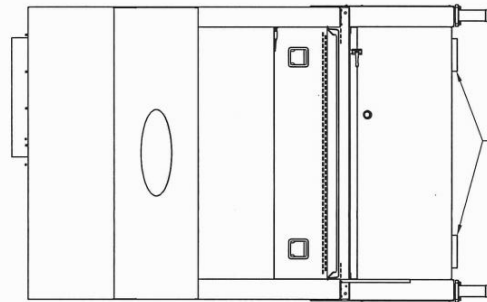

FIG. 3

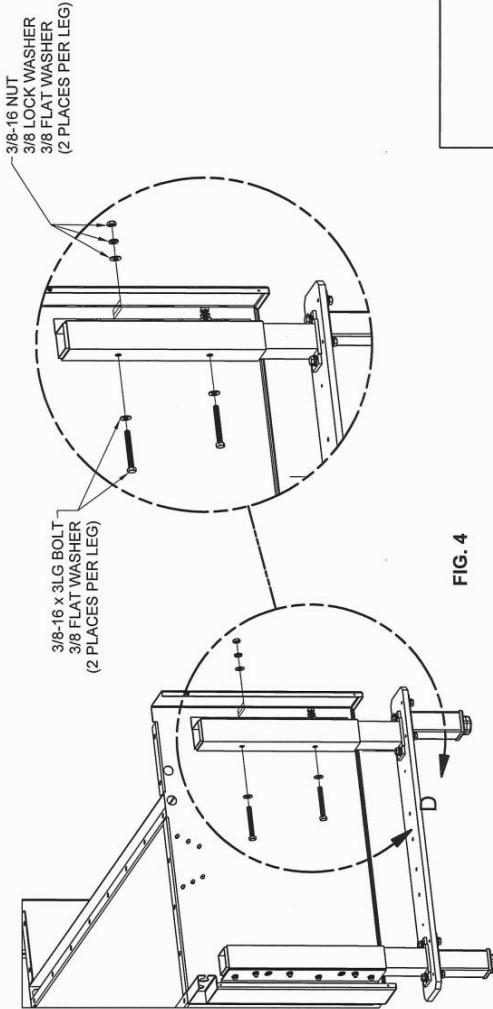
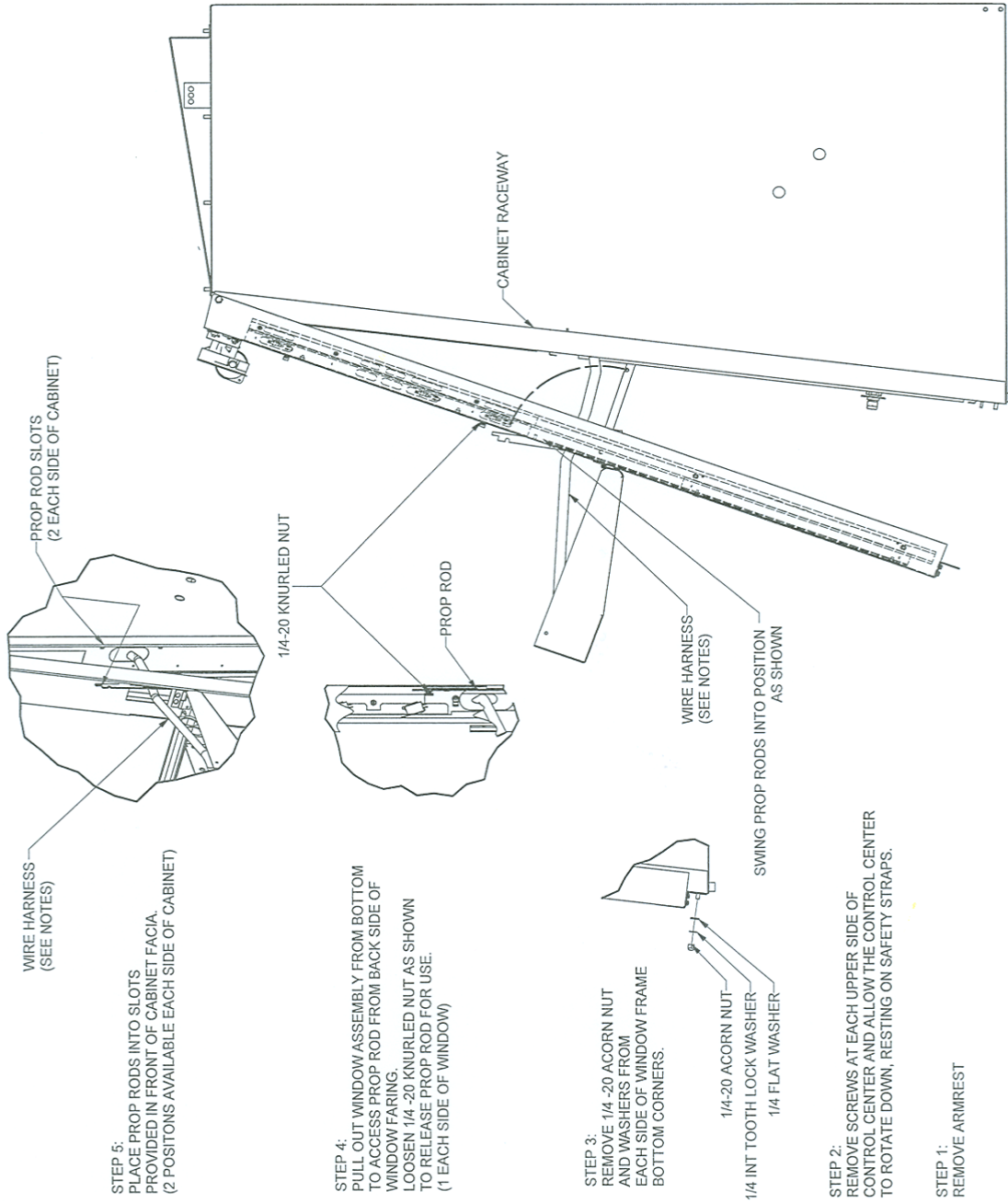

FIG. 4

TITLE		ORIGINAL	
NU-481 / 581 MANUAL BASE ADJUSTMENT			
DFTM	DATE	CHKD	SHEET
LS	6/11/2010	BP	1 OF 1
DRAWING NUMBER		BCD-13923	
		C	



REV	ECO	DESCRIPTION	DATE	DFTM	CHKD
B	11089	ADDED 475/477 TO TITLE	12/17/2010	DHH	DSH



NOTES:

1. WHEN OPENING AND CLOSING HINGED WINDOW CARE MUST BE TAKEN TO ASSURE WIRE HARNESS (1 EACH SIDE) IS ROUTED CORRECTLY THRU THE HOLE INTO AND OUT OF THE RACEWAY.

TITLE NU-475/477/480 WINDOW ASSEMBLY HINGE OPERATION						
DFTM	DATE	CHKO	SHEET	1	OF	1
LS	10/19/2007	DSH				
DRAWING NUMBER		BCD-12271				
		B				

REVISION HISTORY			
REV	ECO	DESCRIPTION	DATE
A	9938	RELEASED TO PRODUCTION	10/19/2007
			LS
			DSR
			M

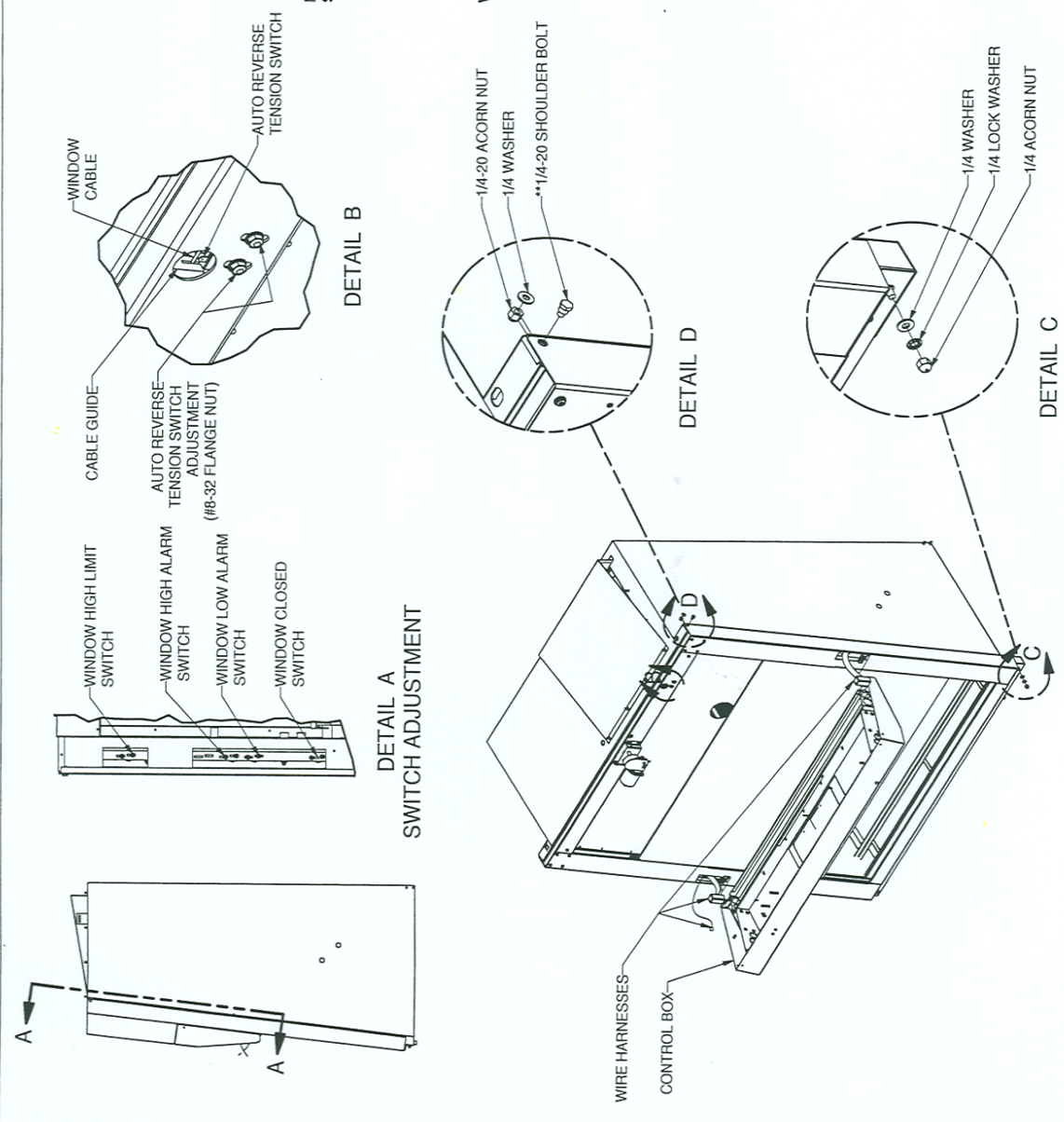

**NOTES:**  
**SWITCH ADJUSTMENT**

1. **DETAIL A**  
WINDOW SWITCH ACCESS IS THRU REAR OF RIGHT SIDE RACEWAY. (LEFT FROM REAR VIEW OF CABINET).
  2. **DETAIL B**  
WITH FLUSH MOUNT FRONT PANEL REMOVED THE AUTO REVERSE TENSION SWITCH IS ADJUSTED BY (2) #8 FLANGE NUTS USING VIEW CUTOUT PROVIDED FOR VISUAL TENSION ADJUSTMENT.
- WINDOW REMOVAL AND MAINTENANCE**
3. WITH FLUSH MOUNT FRONT PANEL REMOVED, DISCONNECT WIRE HARNESES AND PROBE CABLES (2 ON LEFT, 1 ON RIGHT DISCONNECT THE 2 PROBE CABLES AT THE PROBE BOARDS ON THE RIGHT SIDE OF CONTROL BOX).
  4. **DETAIL C**  
REMOVE HINGE LOCK ON THE LEFT HINGE AND CONTROL BOX SUPPORT CABLES (1 EACH SIDE) AND REMOVE CONTROL BOX.
  5. **DETAIL D**  
REMOVE 1/4-20 HARDWARE EACH LOWER CORNER OF WINDOW ALLOWING FOR HINGED OPERATION OF WINDOW.

6. WITH WINDOW FRAME SUPPORTED, (RESTING ON STUDS ON BOTTOM CORNERS) REMOVE THE 1/4-20 SHOULDER BOLTS (1 EACH SIDE).
  7. **ATTENTION: GLASS POSITION SHOULD BE SET IN OPERATING POSITION DURING THE REMOVE / REPLACE PROCEDURE TO AVOID BREAKAGE!**
- CABLE ROUTE AND ATTACHMENT TO GLASS SHOWN ON BCD-12282 IS CRITICAL TO CORRECT WINDOW OPERATION. EQUAL NUMBER REVOLUTIONS ON MAIN PULLEY IS CRITICAL. IF CABLE REPLACEMENT IS REQUIRED FOLLOW THE STEPS ON BCD-12282.
7. REVERSE STEPS 3 - 5 FOR INSTALLATION.

\*\* WHEN RE-ATTACHING THE WINDOW, DO NOT OVER TIGHTEN THE SHOULDER BOLT. (SECURE USING BLUE LOCTITE).

TITLE AUTO WINDOW SWITCH / CABLE ADJUSTMENT AND MAINTENANCE			
DFTM	DATE	CHKD	SHEET
LS	10/19/2007	DSH	1 OF 1
DRAWING NUMBER	BCD-12281		
	A		

**ORIGINAL**

REVISION HISTORY			
REV	ECO	DESCRIPTION	DATE
A	9938	RELEASED TO PRODUCTION	11/19/2007

REV	ECO	DESCRIPTION	DATE	DFTM	GHKD
A	9938	RELEASED TO PRODUCTION	11/19/2007	LS	DSH

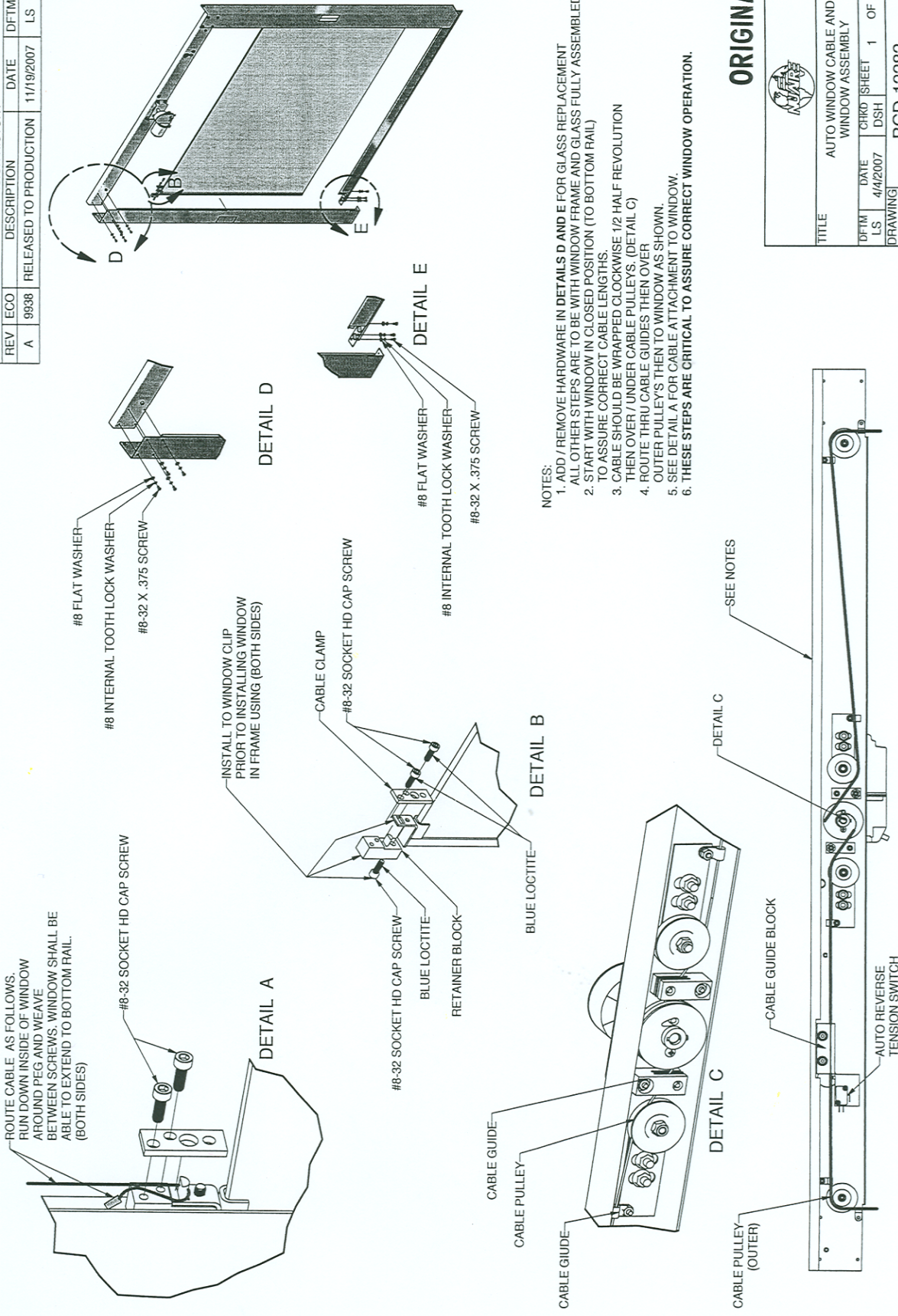

- NOTES:
1. ADD / REMOVE HARDWARE IN DETAILS D AND E FOR GLASS REPLACEMENT. ALL OTHER STEPS ARE TO BE WITH WINDOW FRAME AND GLASS FULLY ASSEMBLED.
  2. START WITH WINDOW IN CLOSED POSITION (TO BOTTOM RAIL) TO ASSURE CORRECT CABLE LENGTHS.
  3. CABLE SHOULD BE WRAPPED CLOCKWISE 1/2 HALF REVOLUTION THEN OVER / UNDER CABLE PULLEYS. (DETAIL C)
  4. ROUTE THRU CABLE GUIDES THEN OVER OUTER PULLEY'S THEN TO WINDOW AS SHOWN.
  5. SEE DETAIL A FOR CABLE ATTACHMENT TO WINDOW.
  6. THESE STEPS ARE CRITICAL TO ASSURE CORRECT WINDOW OPERATION.

**ORIGINAL**



TITLE			
AUTO WINDOW CABLE AND WINDOW ASSEMBLY			
DFTM	DATE	CRD	SHEET
LS	4/4/2007	DSH	1 OF 1
DRAWING NUMBER		BCD-12282	
		A	

REV	ECD	DESCRIPTION	DATE	DFTM	CHKD
A	13685	RELEASED TO PRODUCTION	3/21/2018	TH	BP

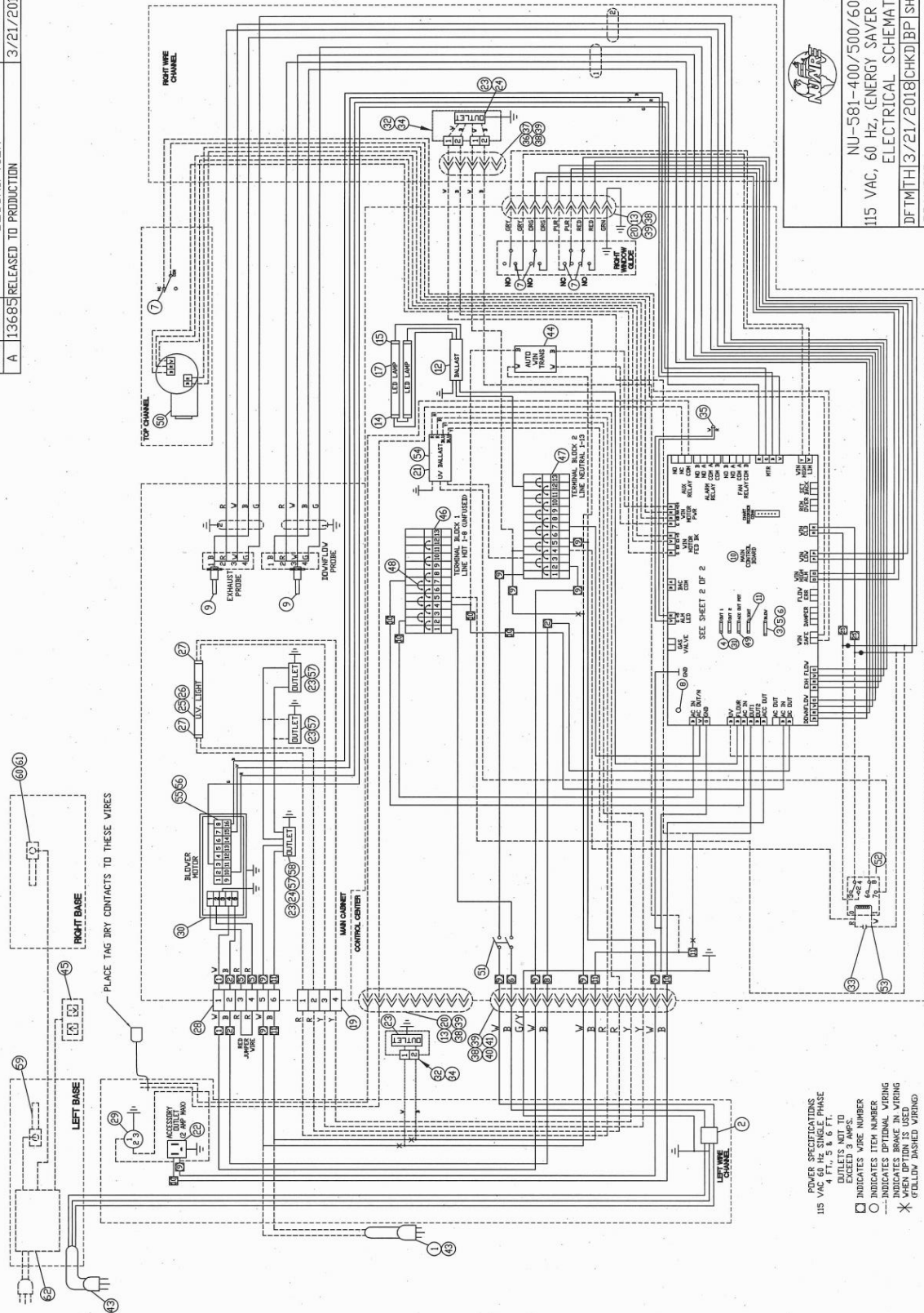

**ORIGINAL**

NU-581-400/500/600  
 115 VAC, 60 Hz, (ENERGY SAVER ECM MOTOR)  
 ELECTRICAL SCHEMATIC  
 DFTMTH/3/21/2018/CHKD/BP SHEET 1 OF 2  
 DRAWING NUMBER BCD-19751 A

- POWER SPECIFICATIONS  
 115 VAC 60 Hz SINGLE PHASE  
 4 FT., 5 & 6 FT.
- INDICATES WIRE NUMBER
  - INDICATES ITEM NUMBER
  - INDICATES OPTIONAL WIRING
  - INDICATES BRANCH IN WIRING
  - \* FOLLOW DASHED WIRING

ITEMITY	DESCRIPTION	QUANTY	P/N	REV	ECD	DESCRIPTION	DATE	DFTM	CHKD
1	ISA POWER CORD 12 FT. MOLDED PLUG	1	X-999543						
2	EMI FILTER	1	X-999319-03						
3									
4	FUSE (3 A) (5x20mm) (OUTLETS)	2	X-999039-03						
5	FUSE (15 A) (1/4 X 1-1/4) (MOTOR, 4, 5 & 6 FT.)	1	X-999082-03						
6									
7	3-SW. ROLLER SPDT	1	X-999690-03						
8	FUSE (4 A) (TRS) (CONTROL BOARD)	2	X-999053-01						
9	DIGITAL VELOCITY SENSOR	1	A-543-1000-A						
10	MAIN CONTROL BOARD	1	A-440-3097-A						
11	FUSE (1 AMP) (5 X 20mm) (LIGHTS)	1	X-999039-13						
12	BALLAST (FL/LED)	1	X-999184-05						
13	CONNECTOR, RECEPTACLE 9 PIN	1	X-999234-02						
14	LAMPHOLDER FIXED BASE BI-PIN	2	X-999418-02						
15	LAMPHOLDER SPRING BASE BI-PIN	2	X-999418-01						
16									
17	LED LAMP (4, 5, 6 FT.)	2	X-999083-04						
18									
19	BULKHEAD CONNECTOR 4 PIN	1	A-425-3654-03						
20	CONNECTOR, PLUG 9 PIN	1	X-999235-02						
21									
22	ACCESSORY OUTLET	1	X-999512						
23	CONVENIENCE OUTLET	1	X-999511						
24	G.F.I. OUTLET	1	X-999530						
25	UV LAMP (4, 5 & 6 FT.)	1	X-999442-01						
26									
27	UV SOLID BASE	2	X-999163-02						
28	BULKHEAD CONNECTOR 6 PIN	1	A-425-3654-01						
29	A/R PIN CONNECTOR	1	X-999247-04						
30	MOTOR, CDD, ECM 5.0, 1 HP (4, 5 & 6 FT.)	1	A-99931-07						
31									
32	A/R OUTLET BOX 1/2 HOLES	1	A-407-132-02						
33	CAPACITOR, 22 MF	1	X-999132-03						
34	A/R BULKHEAD CONNECTOR 2 PIN	1	A-407-1082-01						
35	LED RED PANEL MOUNT	1	X-999248-03						
36	CONNECTOR PLUG 5 PIN	1	X-999046-02						
37	CONNECTOR RECEPTACLE 5 PIN	1	X-999046-02						
38	A/R SOCKET CONTACT	1	X-999244-02						
39	A/R PIN CONTACT	1	X-999244-01						
40	CONNECTOR, PLUG 15 PIN	1	X-999295						
41									
42									
43	2W POWER CORD 12 FT. MOLDED PLUG (FT 1, 5 & 6 FT)	1	X-999536						
44	(AUTO WINDOW) POWER SUPPLY	1	X-999863-05						
45	ACTUATOR SWITCH	1	X-999012-03						
46	TERMINAL BLOCK ASSY CONTAINING: END, 4 PLACE, TERMINAL BLOCK END, 4 PLACE, TERMINAL BLOCK TERMINAL BLOCK 2 PLACE NON-END TERMINAL BLOCK 4 PLACE NON-END	1	A-425-4099-01						
47	TERMINAL BLOCK ASSY CONTAINING: END, 4 PLACE, TERMINAL BLOCK END, 4 PLACE, TERMINAL BLOCK TERMINAL BLOCK 2 PLACE NON-END TERMINAL BLOCK 4 PLACE NON-END	1	A-425-4099-02						
48	JUMPER, TERMINAL BLOCK	3	X-999920-01						
49	FUSE (2A) X 20mm (ACCESSORY OUTLET)	1	X-999039-14						
50	MOTOR, AUTO WINDOW (24V)	1	X-999931-01						
51	SWITCH (DPST)	1	X-999676-04						
52	RELAY (DPDT)	1	X-999866-02						
53	DOUBLE SPADE CONNECTOR	2	X-999926-02						
54	BALLAST, UV, 4, 5 & 6 FT.	1	X-999184-10						
55	CONNECTOR, HOUSING	1	X-999046-03						
56	CONNECTOR, SOCKET	1	X-999866-03						
57	A/R 20 AMP OUTLET	1	X-999509						
58	A/R 20 AMP GFI OUTLET	1	X-999330-01						
59	ACTUATOR 1/2SW CABLE	1	X-999012-08						
60	ACTUATOR 1/2.5SW CABLE	1	X-999012-05						
61	ACTUATOR 1/3.5SW CABLE	1	X-999012-07						
62	ACTUATOR CONTROL BOX (15 VAC)	1	X-999012-04						

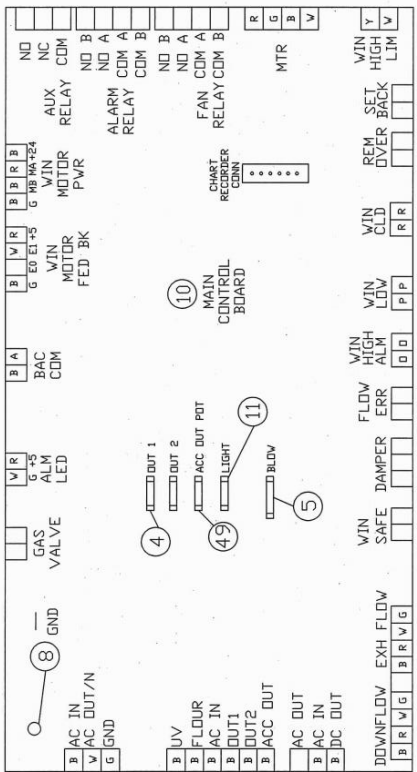

**ORIGIN**

NU-581-400/500/600  
115 VAC, 60 HZ, (ENERGY SAVER ECM MOTOR)  
ELECTRICAL SCHEMATIC

DFTM TH 3/21/2018 CHKD BP SHEET 2 OF 2  
DRAWING NUMBER BCD-19751 A

POWER SPECIFICATIONS  
115 VAC 60 HZ SINGLE PHASE  
OUTLETS NOT TO EXCEED 3 AMPS.  
O INDICATES ITEM NUMBER  
--- INDICATES OPTIONAL WIRING  
\* INDICATES BRAKE IN WIRING WHEN OPTION IS USED  
(FOLLOW DASHED WIRING)