

REV	CO	DESCRIPTION	DATE	DFTR	CHKD
A	000365	RELEASED TO PRODUCTION	6/3/2020	TH	MSS

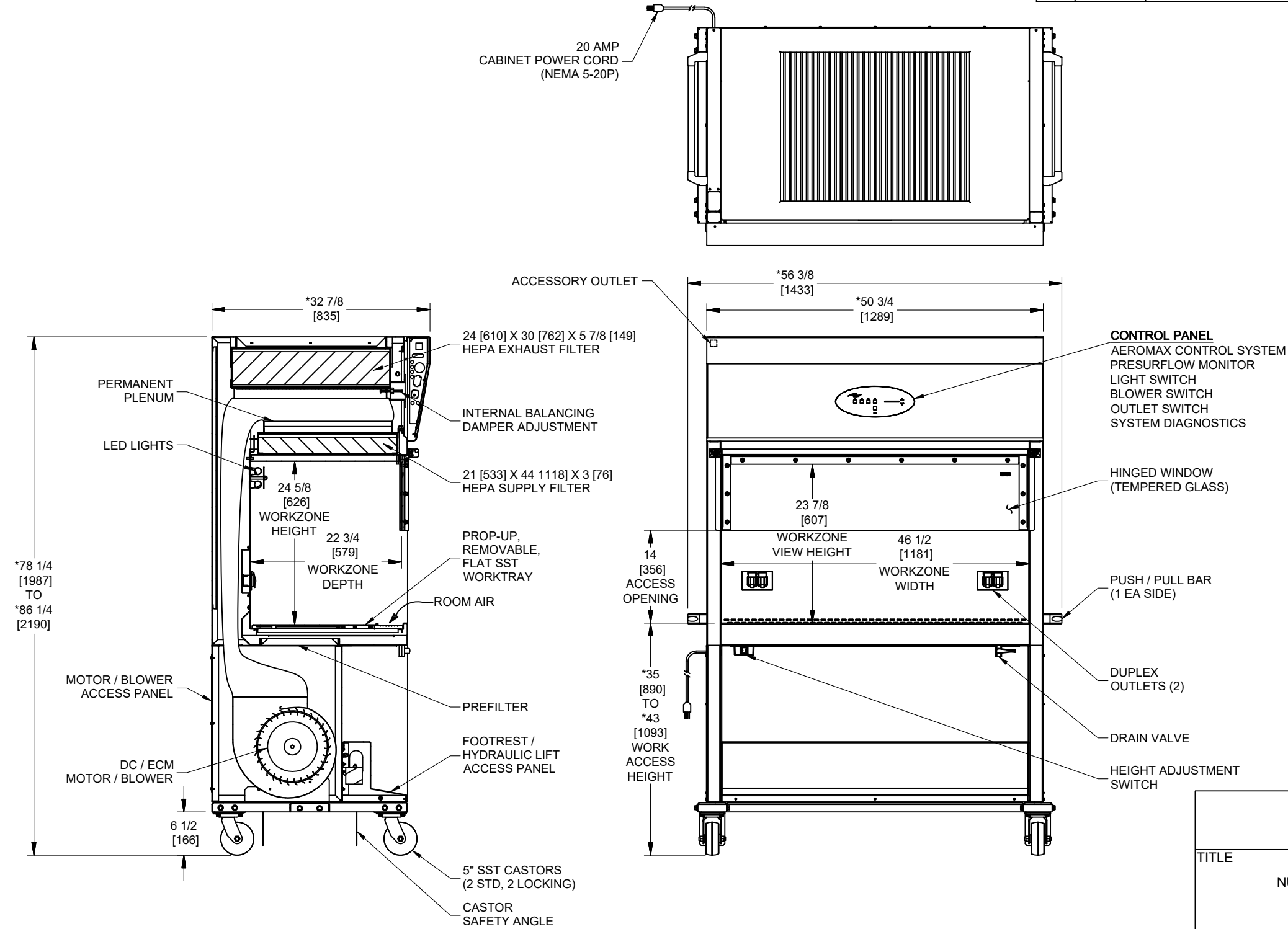

* OVERALL DIMENSIONAL TOLERANCE ±1/4 [6.35]
 ALL OTHER DIMENSIONS ±1/8 [3.17]

INCH
MILLIMETER



TITLE
 NU-640-400 CLASS II, TYPE A2 SPECIFICATION
 DRAWING

DFTR	TH	DATE	6/1/2020	CHKD	MSS	SHEET	1	OF	1	
DRAWING NUMBER		CD-000032					A			