



# MVE Cryopreservation for Life Sciences

Storage & Transport Systems for MVE Cryopreservation



# Contents



Temperature Chart & Product Selector Guide.....	3
MVE Fusion® Series.....	4
MVE TS (Touch Screen).....	6
MVE HEco™ 800 Series Freezers.....	8
MVE HEco™ 1500 Series Freezers.....	10
MVE HEco™ 1800 Series Freezers.....	12
MVE High Efficiency 800 -190°C Series.....	14
MVE High Efficiency 1500 -190°C Series.....	16
MVE High Efficiency 1800 -190°C Series.....	18
MVE Variö® Series Freezers.....	20
MVE Series.....	22
MVE 816P-2T-190.....	24
MVE Stock Series.....	26
MVE CryoCart.....	28
MVE Research Dewars.....	29
MVE CryoSystem 6000 Full Auto.....	30
MVE CryoSystem Series.....	32
MVE Lab Series.....	34
MVE SC Series.....	36
MVE XC Series.....	38
MVE Doble Series.....	40
MVE Vapor Series.....	42
MVE CryoCube™ & BL-7.....	44
MVE CryoShipper Series.....	45
PDF Logger®.....	47
MVE 1536 Dry Shipper.....	48
Installation Photo.....	50
MVE's Cryogenic Solutions.....	52

# Temperature Chart

MVE is the leading global manufacturer of vacuum insulated products and cryogenic systems. More than fifty years ago, we set the standard for storage of biological materials at low temperatures. Today, we continue to exceed these standards. Industries from around the world look to MVE for excellence and innovation. Our solutions empower industries to better utilize cryogenic technology. In this manner, MVE continues to make a vital contribution in today's biomedical Life Sciences industry.

Recommended maximum temperature for storage of biological samples.

MATERIAL TO BE STORED	VOLUME	CONTAINER	INVENTORY CONFIGURATION	CRITICAL TEMPERATURE
Algae	0.5 - 1.0 mL	Cryovial	Boxes or canes	-150°C
Blood	0.5 - 500 mL	Cryovial/Blood Bag	Boxes or canes/bag rack	-150°C
Cells:				
Animals / Human	0.5 - 1.0 mL	Cryovial	Boxes or canes	-150°C
Plant	0.5 - 1.0 mL	Cryovial	Boxes or canes	-150°C
Embryos		Straw	Canes	-150°C
Fungi:				
Mycelium	0.5 - 1.0 mL	Cryovial	Boxes or canes	-150°C
Hybridomas	0.5 - 1.0 mL	Cryovial	Boxes or canes	-150°C
Phage:				
Libraries	0.5 - 1.0 mL	Cryovial	Boxes or canes	-150°C
Protozoa	0.5 - 1.0 mL	Cryovial	Boxes or canes	-150°C
Viruses: Animal In Cells	0.5 - 1.0 mL	Cryovial	Boxes or canes	-150°C

## Product Selector Guide

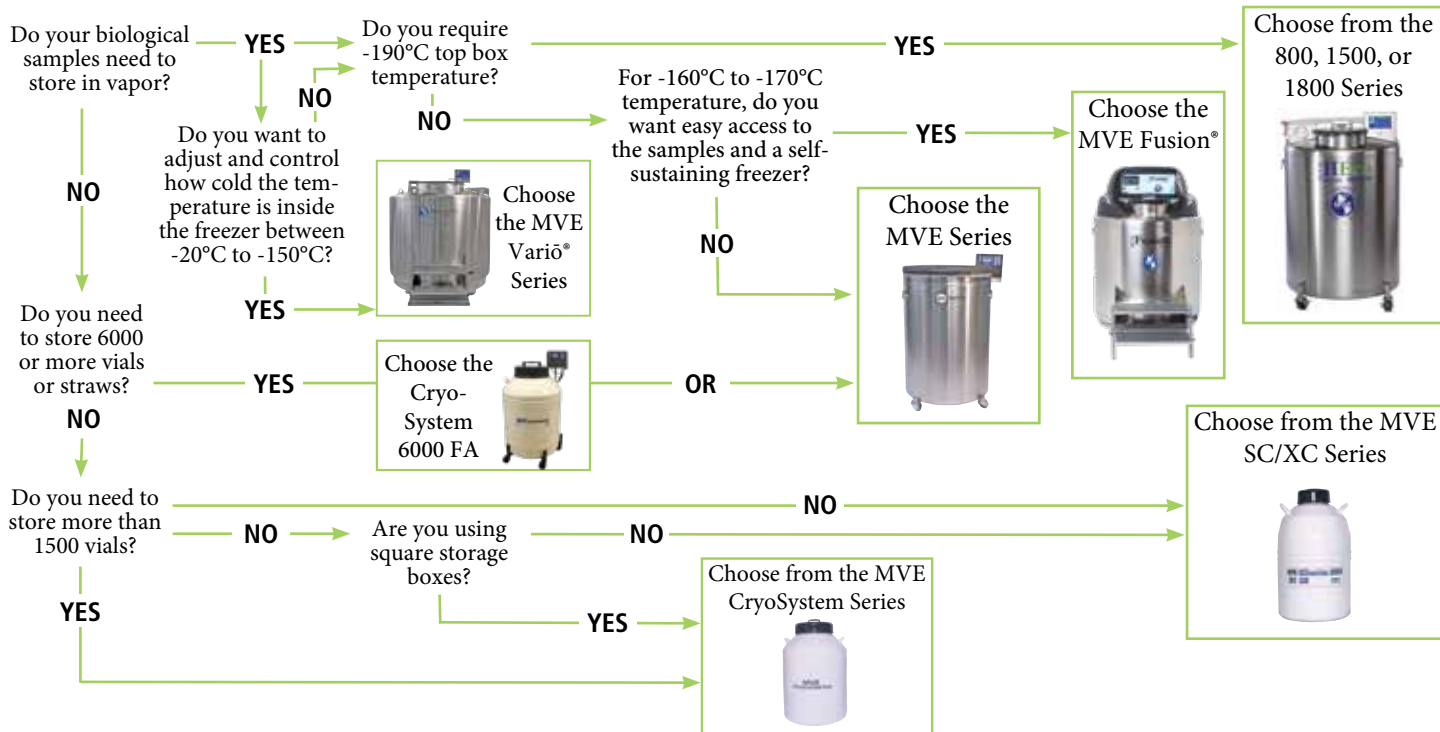

Visit [www.mvebio.com](http://www.mvebio.com) for more information.

© 2021 MVE Biological Solutions reserves the right to discontinue its products, or change the prices, materials, equipment, quality, descriptions, specifications and/or processes to its products at any time without prior notice and with no further obligation or consequence. All rights not expressly stated herein are reserved by us, as applicable.

# MVE Fusion® Series



## Features include

- Self-sustaining
- Dry sample storage
- Lowest leftover height
- Two tier folding step



Introducing the MVE Fusion® Freezer, the world's first self-sustaining cryogenic freezer. The MVE Fusion is a refrigerated liquid-based bio-storage freezer, similar in appearance and construction to an MVE High Efficiency LN<sub>2</sub> freezer. The design of the MVE Fusion is to provide cold storage capabilities, with no need for liquid cryogen during normal operation. The MVE Fusion can be used in remote locations, isolated rooms, high elevation facilities, and facilities with little or no vacuum jacketed pipe infrastructures. The MVE Fusion does not require constant LN<sub>2</sub> supply.

[www.mvebio.com](http://www.mvebio.com)  
844-MVE-CRYO

MVE Fusion®

**Maximum Storage Capacity**

1.2 & 2 ml Vials (Internally Threaded)	31,200
Number of Racks 100 cell boxes	20
Number of Racks 25 cell boxes	16
Number of Stages per Rack	13

**Performance**

LN <sub>2</sub> Capacity L	50 (inner pressure vessel)
LN <sub>2</sub> Capacity Under Tray L	(not necessary)

**Unit Dimensions**

Neck Opening in. (mm)	12.5 (318)
Usable Internal Height in. (mm)	29.6 (752)
Inner Diameter in. (mm)	38.4 (975)
Overall Height in. (mm)	65 (1625)
Overall Depth in. (mm)	57 (1450)
Liftover Height in. (mm)	37.1 (944)
Door Width Requirement** Outer Diameter in. (mm)	43.5 (1105) with handles
Weight Empty est. lb. (kg)	750 (340) estimated
Weight Liquid Full* (Freezer with 50L and Cryocooler) est. lb. (kg)	830 (377) without racks estimated

**Blood Bag Capacities**

	Total Bags	Bags/Frame	No. Frames
791 OS/U (25 ml)	2296	7	328
4R9951 (50 ml)	1484	7	212
4R9953 (250 ml)	752	4	188
4R9955 (500 ml)	592	4	148
DF200 (200 ml)	416	4	104
DF700 (700 ml) (will not fit through neck opening)			

\* Without inventory

\*\*Minimum width required for vessel to pass through opening. Footprint may vary. Contact Tech Service for detailed drawings.

**TWO Year Standard Warranty • FIVE Year Vacuum Warranty**

**Rack Layout**

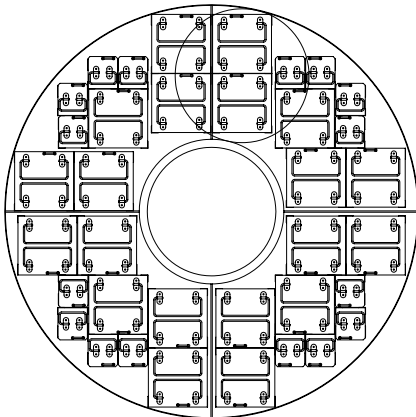

Visit [www.mvebio.com](http://www.mvebio.com) for more information.

© 2021 MVE Biological Solutions reserves the right to discontinue its products, or change the prices, materials, equipment, quality, descriptions, specifications and/or processes to its products at any time without prior notice and with no further obligation or consequence. All rights not expressly stated herein are reserved by us, as applicable.



# MVE TS (Touch Screen)

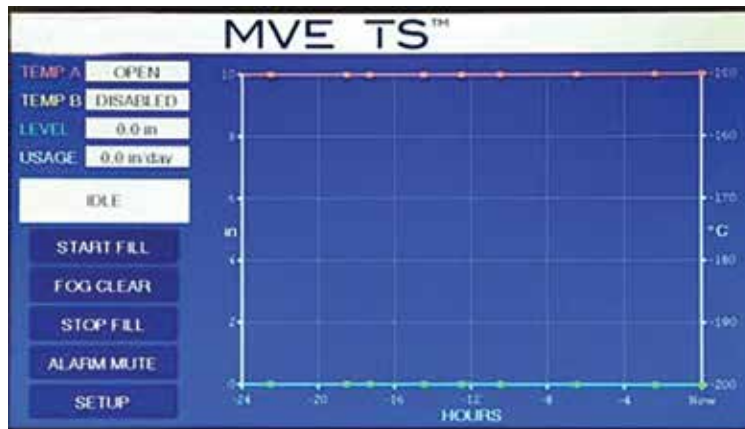

MVE TS employs a variety of advanced features that enable the controller to monitor and control the environment inside a freezer with a high level of precision.

The new screen features X, Y graph for quick view of temperature and liquid nitrogen level!

## Liquid Nitrogen Level Measurement

MVE TS uses a differential pressure system to determine the LN<sub>2</sub> level to an accuracy of ± 0.5 in. (15 mm) and a resolution of 0.1 in. (5.0 mm). Unlike alternative level sensing systems, differential pressure allows the exact level to be measured and displayed. Using the simple single point calibration in a range of 3.0 in. to 48.0 in. (75 mm to 1220 mm), the patented, self-maintaining, closed-loop system displays in inches, millimeters, or a percentage full.

## Automatic Liquid Nitrogen Level Control

The fully automated LN<sub>2</sub> level control system is based on user-defined parameters that can be electronically adjusted over the entire level range. The parameters include Low Level Alarm, Low Level Fill Point, High Level Fill Point and High Level Alarm. The redundant Dual Solenoid Valves for overflow protection run on 24 VDC, 1.0 amp (max).

## Liquid Usage

This exclusive feature provides an estimation of liquid usage to track LN<sub>2</sub> consumption and can provide an early failure warning to allow sufficient time to implement corrective action and save irreplaceable samples.

## User-Defined Alarms

A total of 18 audio/visual alarms are used to alert the user to any potential or developing problems. The alarms include: High Temperatures, Low Temperatures, High Level, Low Level, Liquid Usage, Maximum Fill Time, Gas Bypass, Stuck Open/Closed, Temperature Calibrations, Low Battery, Power Failure, Lid Open and Communication Loss.

## Remote Alarm Monitoring

Alarm monitoring includes Global/Discrete Remote Alarm Relay.

## Temperature Measurement

Two independent temperature measurement channels are employed to accurately measure the temperature across the

entire storage space. The two platinum RTD sensors have an accuracy of ± 1.0°C and a resolution of 0.1°C. The temperature can be displayed in °C, °F or K. The single or two point calibration also has altitude compensation for the highest accuracy.

## Temperature Inlet Settings (Hot Gas Bypass)

This unique feature is able to vent warm nitrogen gas from the supply line before initiating a fill. This prevents warm gas from entering the freezer space, which helps maintain a stable temperature gradient and increases the efficiency by reducing excess LN<sub>2</sub> evaporation.

## Event Log / Data Storage

Store vital, unalterable, time-stamped data in nonvolatile memory. This is a great tool for assessing freezer performance and troubleshooting any problems. The memory can store 30,000 events, an estimated 10 years of storage capacity. The data includes time-stamped temperatures, LN<sub>2</sub> level, liquid usage, and any alarms or events.

## Password Security

The multilevel security system comprised of up to ten user-specific programmable passwords and four security levels can be customized to grant or restrict personnel access to certain menus and settings.

## Communication Capabilities

One independent port can be used to communicate with other MVE TS controllers, a remote PC, serial printer, or other RS-485 networks and devices. Options include ASCII, MODBUS, Printer and One Fill All Fill (OFAF).

## Ethernet Capabilities

One independent RJ45 port can be used for network connection.

Temp A, B, and Level is displaced when navigating the Menu

Idle Status indicates freezer on standby. Changes to Bypassing or Filling

Alarm Status Indicator (changes to Red)

Fog Clear Icon (replaced Manual Fill Button)

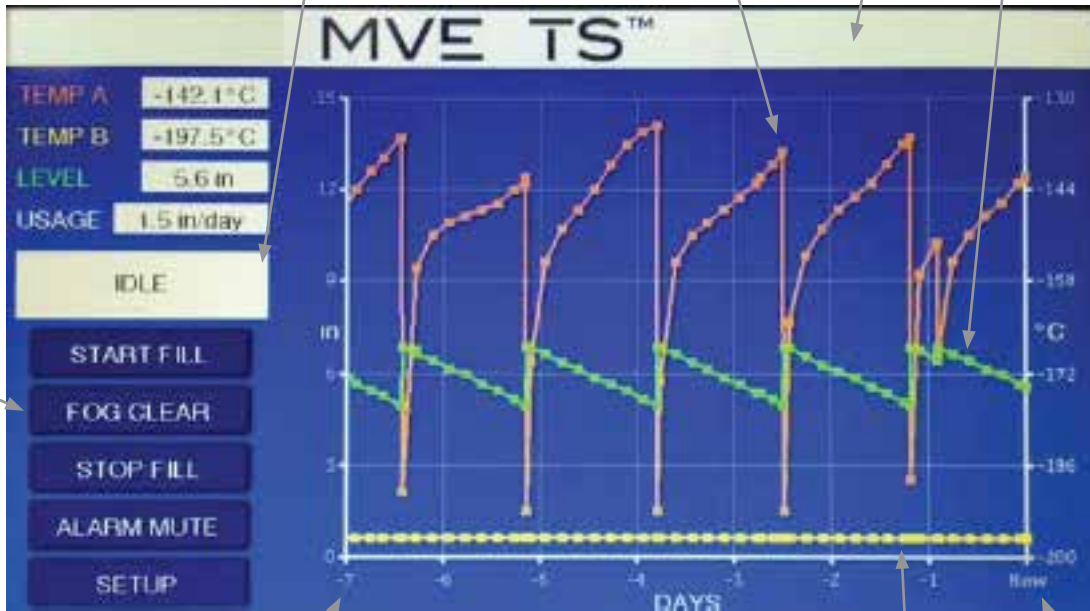

Trend Data adjustable from one day, 7 days, or 30 days

Temp B

Now Data (Present Data)

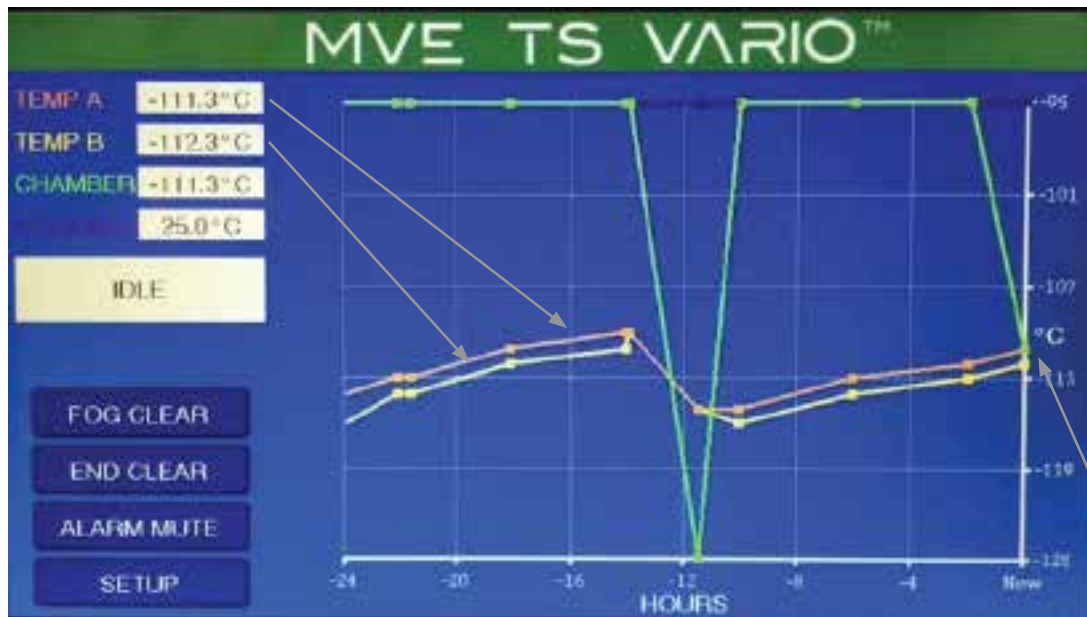

Temperature A & B and Chamber Temp Display on Graph



Visit [www.mvebio.com](http://www.mvebio.com) for more information.

© 2021 MVE Biological Solutions reserves the right to discontinue its products, or change the prices, materials, equipment, quality, descriptions, specifications and/or processes to its products at any time without prior notice and with no further obligation or consequence. All rights not expressly stated herein are reserved by us, as applicable.

# MVE HEco™ 800 Series Freezers



- Standard One-Tier Step
- Optional Two-Tier Steps



## Features include

- LN<sub>2</sub> efficiency
- Fully enclosed wiring and plumbing
- Vacuum jacketed transfer hose
- Dry sample storage
- -190°C top box temperature
- Lowest liftover height
- Single step standard
- Optional double-tier step



Dura-Cyl® 230  
Liquid Cylinders  
for LN<sub>2</sub> use

## Featuring the MVE Touch Screen & TEC 3000

The MVE HEco Series is the next generation High Efficiency freezer from MVE. With their unique shroud design, streamlined LN<sub>2</sub> plumbing, and vacuum jacketed transfer hose, the MVE HEco 800 Series freezers provide efficient use of LN<sub>2</sub>, making them the most efficient vapor freezers available. These next generation high efficiency freezers incorporate hinged work surfaces that fully enclose all electronics and plumbing to enhance overall safety and usability.

The technical and visual improvements combine to create a more aesthetically pleasing freezer that offers greater functionality. As with all of MVE's cryogenic freezers, the MVE HEco 800 Series freezers are available in three unique sizes and provide maximum storage density as well as the longest hold time and highest sample security in the industry.

MVE HEco 800 Temperature Test\*

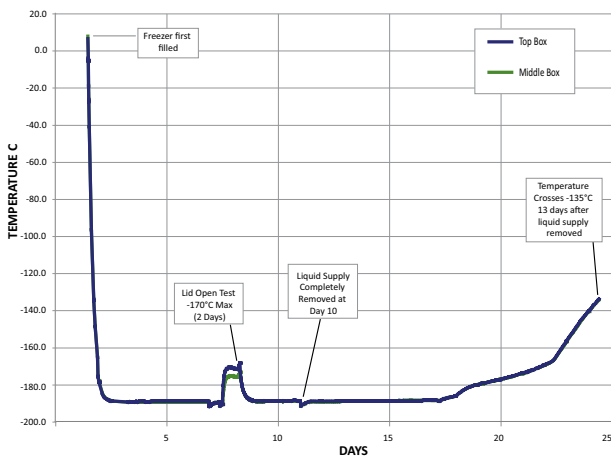

## Temperature Test Graph

\* Temperature test indicates typical performance of HEco Series freezer with full inventory system and factory recommended level settings. Actual performance may vary with atmospheric conditions and usage.



	MVE HEco 815P-190	MVE HEco 818P-190	MVE HEco 819P-190						
<b>Maximum Storage Capacity</b>									
1.2 & 2 ml Vials (Internally Threaded)	15,600	18,200	19,500						
Quantity of Large Racks 100 cell boxes	12	12	12						
Quantity of Mini Racks 25 cell boxes	4	4	4						
Number of Shelves per Rack	12	14	15						
<b>Performance</b>									
LN <sub>2</sub> Capacity w/o Inventory L est.	349	403	446						
LN <sub>2</sub> Capacity at Vapor Platform L est.	51	55	55						
<b>Unit Dimensions</b>									
Neck Opening in. (mm)	12.5 (317)	12.5 (317)	12.5 (317)						
Usable Internal Height in. (mm)	26.5 (673)	30.7 (781)	34.5 (877)						
Inner Diameter in. (mm)	28.8 (731)	28.8 (731)	28.8 (731)						
Overall Height in. (mm)	49.5 (1257)	53.9 (1370)	57.70 (1465)						
Liftover Height in. (mm)	39 (991)	43.8 (1115)	47.63 (1209)						
Door Width Requirement** Outer Diameter in. (mm)	32.0 (813)	32.0 (813)	32.0 (813)						
Door Width Requirement, with handles** in. (mm)	33.2 (843)	33.2 (843)	33.2 (843)						
Weight Empty* lb. (kg)	475 (215)	495 (225)	515 (234)						
Weight Liquid Full* lb. (kg) est.	1134 (514)	1168 (530)	1340 (608)						
<b>Blood Bag Capacities</b>									
	Total Bags	Bags/ Frame	No. Frames	Total Bags	Bags/ Frame	No. Frames	Total Bags	Bags/Frame	No. Frames
791 OS/U Medsep (25 ml)	1,224	6	204	1428	7	204	1,836	9	204
4R9951 (50 ml)	768	6	128	896	7	128	1024	8	128
4R9953 (250 ml)	416	4	104	416	4	104	520	5	104
4R9955 (500 ml)	304	4	76	304	4	76	380	5	76
DF200 (200 ml)	236	4	59	236	4	59	295	5	59

**TWO Year Parts Warranty • FIVE Year Vacuum Warranty**

\* Without inventory

\*\*Minimum width required for vessel to pass through opening. Footprint may vary. Contact Tech Service for detailed drawings.

## Rack Layouts

Square Rack Layout (P)

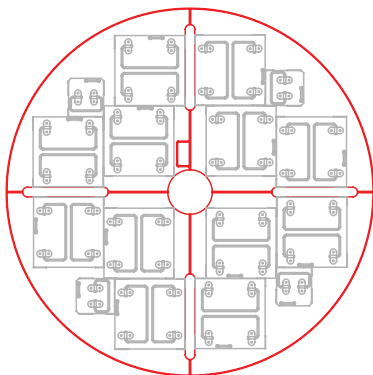

791 OS/U Layout

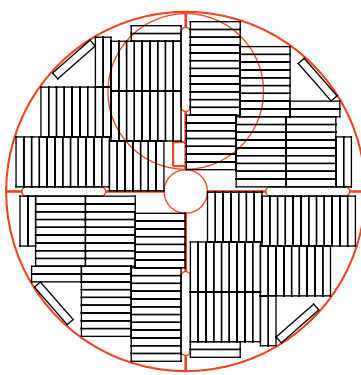

Visit [www.mvebio.com](http://www.mvebio.com) for more information.

© 2021 MVE Biological Solutions reserves the right to discontinue its products, or change the prices, materials, equipment, quality, descriptions, specifications and/or processes to its products at any time without prior notice and with no further obligation or consequence. All rights not expressly stated herein are reserved by us, as applicable.

# MVE HEco™ 1500 Series Freezers



## Features include

- LN<sub>2</sub> efficiency
- Fully enclosed wiring and plumbing
- Vacuum jacketed transfer hose
- Dry sample storage
- -190°C top box temperature
- Lowest liftover height
- Two tier folding step

## Featuring the MVE Touch Screen & TEC 3000

The MVE HEco 1500 Series freezers provide efficient use of LN<sub>2</sub>, making them the most efficient vapor freezers available. These next generation high efficiency freezers incorporate a hinged work surfaces that fully enclose all electronics and plumbing to enhance overall safety and usability. The technical and visual improvements combine to create a more aesthetically pleasing freezer that offers greater functionality. As with all of MVE's cryogenic freezers, the MVE HEco 1500 Series freezers are available in three unique sizes and provide maximum storage density as well as the longest hold time and highest sample security in the industry.

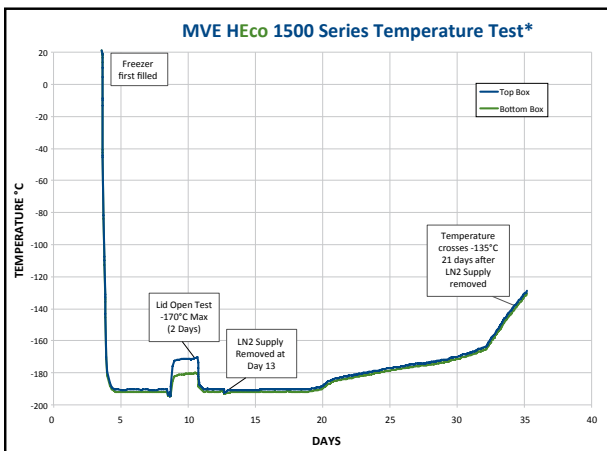

Temperature Test Graph

\* Temperature test indicates typical performance of HEco Series freezer with full inventory system and factory recommended level settings. Actual performance may vary with atmospheric conditions and usage.

	MVE HEco 1536P-190	MVE HEco 1539P-190	MVE HEco 1542R-190						
<b>Maximum Storage Capacity</b>									
1.2 & 2 ml Vials (Internally Threaded)	36,400	39,200	42,000						
Quantity of Large <i>Racks</i> 100 cell boxes	24	24	26						
Quantity of Mini <i>Racks</i> 25 cell boxes	16	16	16						
Number of Shelves per Rack	13	14	14						
<b>Performance</b>									
LN <sub>2</sub> Capacity w/o Inventory L est.	730	768	768						
LN <sub>2</sub> Capacity at Vapor Platform L est.	115	115	115						
<b>Unit Dimensions</b>									
Neck Opening in. (mm)	17.4 (442)	17.4 (442)	17.4 (442)						
Usable Internal Height in. (mm)	28.7 (730)	30.8 (782)	30.8 (782)						
Inner Diameter in. (mm)	38.5 (978)	38.5 (978)	38.5 (978)						
Overall Height in. (mm)	54.7 (1389)	56.8 (1442)	56.8 (1442)						
Liftover Height in. (mm)	37.3 (947)	39.4 (999)	39.4 (999)						
Door Width Requirement** Outer Diameter in. (mm)	42.0 (1067)	42.0 (1067)	42.0 (1067)						
Door Width Requirement, with handles** in. (mm)	43.3 (1099)	43.3 (1099)	43.3 (1099)						
Weight Empty* lb. (kg)	700 (318)	700 (318)	700 (318)						
Weight Liquid Full* lb. (kg) est.	2000 (907)	2100 (953)	2100 (953)						
<b>Blood Bag Capacities</b>									
	Total Bags	Bags/ Frame	No. Frames	Total Bags	Bags/ Frame	No. Frames	Total Bags	Bags/ Frame	No. Frames
791 OS/U Medsep (25 ml)	2,905	7	415	3,320	8†	415	3,184	8†	398
4R9951 (50 ml)	1,488	6	248	1,736	7	248	1,687	7	241
4R9953 (250 ml)	812	4	203	812	4	203	768	4	192
4R9955 (500 ml)	608	4	152	608	4	152	576	4	144
DF200 (200 ml)	496	4	124	496	4	124	488	4	122
DF700 (700 ml)	256	4	64	256	4	64	264	4	66

**TWO Year Parts Warranty • FIVE Year Vacuum Warranty**

\* Without inventory

\*\*Minimum width required for vessel to pass through opening. Footprint may vary. Contact Tech Service for detailed drawings.

† Between usable height and clearance. Please refer to specifications.

## Rack Layout

Square Rack Layout (P)

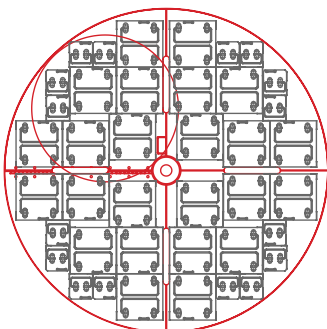

4R9951 Layout (R)

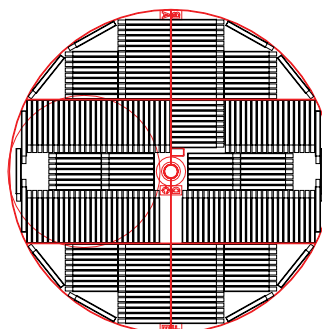

Visit [www.mvebio.com](http://www.mvebio.com) for more information.

© 2021 MVE Biological Solutions reserves the right to discontinue its products, or change the prices, materials, equipment, quality, descriptions, specifications and/or processes to its products at any time without prior notice and with no further obligation or consequence. All rights not expressly stated herein are reserved by us, as applicable.

# MVE HEco™ 1800 Series Freezers



## Features include

- LN<sub>2</sub> efficiency
- Fully enclosed wiring and plumbing
- Vacuum jacketed transfer hose
- Dry sample storage
- -190°C top box temperature
- Lowest liftover height
- Two tier folding step

## Featuring the MVE Touch Screen & TEC 3000

The MVE HEco 1800 Series freezers provide efficient use of LN<sub>2</sub>, making them the most efficient vapor freezers available. The 1800 series provides the option for greater storage in one freezer. These next generation high efficiency freezers incorporate a hinged work surfaces that fully enclose all electronics and plumbing to enhance overall safety and usability. The technical and visual improvements provide an aesthetically more pleasing freezer while offering greater functionality. As with all of MVE's cryogenic freezers, the MVE HEco 1800 Series freezers provide maximum storage density as well as the longest hold time and highest sample security in the industry.

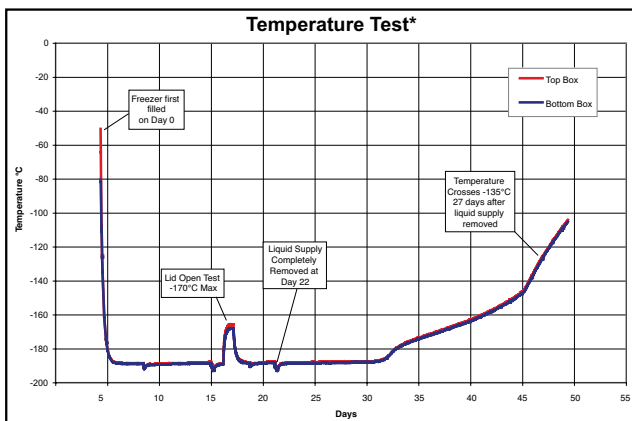

Temperature Test Graph

\* Temperature test indicates typical performance of HEco Series freezer with full inventory system and factory recommended level settings. Actual performance may vary with atmospheric conditions and usage.

	MVE HEco 1879P-190	MVE HEco 1881R-190	MVE HEco 1892P-190	MVE HEco 1894R-190								
<b>Maximum Storage Capacity</b>												
1.2 & 2 ml Vials (Internally Threaded)	79,950	81,900	92,250	94,500								
Quantity of Large Racks 100 cell boxes	54	60	54	60								
Quantity of Mini Racks 25 cell boxes	30	12	30	12								
Number of Shelves per Rack	13	13	15	15								
<b>Performance</b>												
LN <sub>2</sub> Capacity L.	1516	1521	1737	1732								
LN <sub>2</sub> Capacity Under Tray L	292	305	282	300								
<b>Unit Dimensions</b>												
Neck Opening in. (mm)	24.7 (627)	24.7 (627)	24.7 (627)	24.7 (627)								
Usable Internal Height in. (mm)	29.5 (749)	29.2 (741)	34.5 (876)	34.2 (868)								
Inner Diameter in. (mm)	56.0 (1422)	54.8 (1391)	56.0 (1422)	54.7 (1389)								
Overall Height in. (mm)	63.7 (1618)	63.7 (1618)	68.6 (1742)	68.6 (1742)								
Liftover Height in. (mm)	38.8 (985)	38.8 (985)	44.0 (1118)	44.0 (1118)								
Door Width Requirement** Outer Diameter in. (mm)	60.0 (1524)	60.0 (1524)	60.0 (1524)	60.0 (1524)								
Weight Empty* lb. (kg)	1721 (781)	1721 (781)	1721 (781)	1721 (781)								
Weight Liquid Full* lb. (kg) est.	4830 (2191)	4830 (2191)	4875 (2211)	4875 (2211)								
<b>Blood Bag Capacities</b>												
	Total Bags	Bags/ Frame	No. Frames	Total Bags	Bags/ Frame	No. Frames	Total Bags	Bags/ Frame	No. Frames	Total Bags	Bags/ Frame	No. Frames
791 OS/U Medsep (25 ml)	5,866	7	838	5,628	7	804	6,704	8	838	6,432	8	804
4R9951 (50 ml)	2,952	6	492	2,940	6	490	3,936	8	492	3,920	8	490
4R9953 (250 ml)	1,584	4	396	1,608	4	402	1,980	5	396	2,010	5	402
4R9955 (500 ml)	1,104	4	276	1,240	4	310	1,380	5	276	1,550	5	310
DF200 (200 ml)	960	4	240	984	4	246	1,200	5	240	1,230	5	246
DF700 (700 ml)	504	4	126	544	4	136	630	5	126	680	5	136

**TWO Year Parts Warranty • FIVE Year Vacuum Warranty**

\* Without inventory

\*\* Minimum width required for vessel to pass through opening. Footprint may vary. Contact Tech Service for detailed drawings.

## Rack Layout

Square Rack Layout (P)

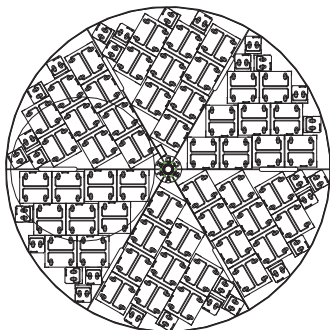

4R9951 Layout (R)

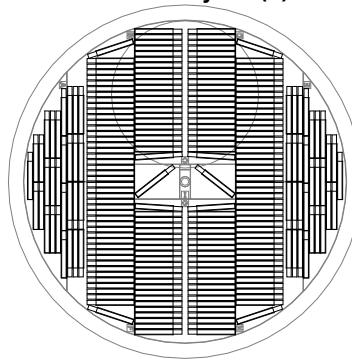

Visit [www.mvebio.com](http://www.mvebio.com) for more information.

© 2021 MVE Biological Solutions reserves the right to discontinue its products, or change the prices, materials, equipment, quality, descriptions, specifications and/or processes to its products at any time without prior notice and with no further obligation or consequence. All rights not expressly stated herein are reserved by us, as applicable.



# MVE High Efficiency 800 -190°C Series



## Features include

- Dry sample storage
- -190°C top box temperature
- Lowest liftover height
- Largest LN<sub>2</sub> capacity at vapor platform
- Optional Battery Backup



- Optional One-Tier and Two-Tier Steps

## Featuring the TEC 3000

The MVE High Efficiency 800 Freezer Series provides vapor storage temperature at -190°C. Available in three unique sizes these freezers provide maximum storage density and provide the industry's longest hold time.

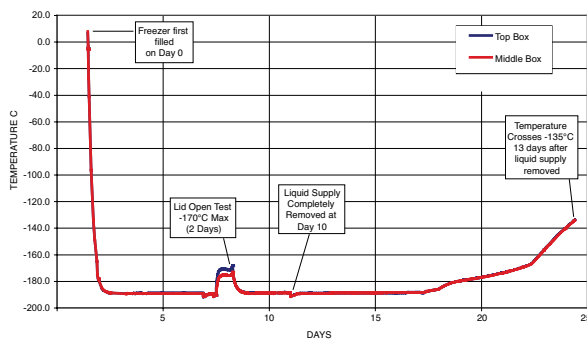

## Temperature Test Graph

\* Temp Test indicates typical performance of 800 Series -190°C freezer with full inventory system and factory recommended level settings. Actual performance may vary with atmospheric conditions and usage.

	MVE 815P-190	MVE 819P-190				
<b>Maximum Storage Capacities</b>						
1.2 & 2 ml Vials (Internally Threaded)	15,600	19,500				
Quantity of Large Racks 100 cell boxes	12	12				
Quantity of Mini Racks 25 cell boxes	4	4				
Number of Shelves per Rack	12	15				
<b>Performance</b>						
LN <sub>2</sub> Capacity w/o Inventory L. est.	370	463				
LN <sub>2</sub> Capacity at Vapor Platform L. est.	52	55				
<b>Unit Dimensions</b>						
Neck Opening in. (mm)	12.5 (317)	12.5 (317)				
Usable Internal Height in. (mm)	26.5 (673)	34.5 (877)				
Inner Diameter in. (mm)	28.8 (731)	28.8 (731)				
Overall Height w/Autofill in. (mm)	57.0 (1448)	65.0 (1651)				
Door Width Requirement** Outer Diameter in. (mm)	32.0 (813)	32.0 (813)				
Door Width Requirement** with handles in. (mm)	33.2 (843)	33.2 (843)				
Weight Empty* lb. (kg)	475 (215)	515 (234)				
Weight Liquid Full* lb. (kg) est.	1134 (514)	1340 (608)				
<b>Blood Bag Capacities</b>						
	<b>Total Bags</b>	<b>Bags/ Frame</b>	<b>No. Frames</b>	<b>Total Bags</b>	<b>Bags/ Frame</b>	<b>No. Frames</b>
791 OS/U Medsep (25 ml)	1,224	6	204	1,836	9	204
4R9951 (50 ml)	768	6	128	1024	8	128
4R9953 (250 ml)	416	4	104	520	5	104
4R9955 (500 ml)	304	4	76	380	5	76
DF200 (200 ml)	236	4	59	295	5	59

**TWO Year Parts Warranty • FIVE Year Vacuum Warranty**

Conforms to MDD 93/42/EEC, the Medical Device Directive for the EU. Freezer systems UL/C-UL Listed.

\* Without inventory

\*\*Minimum width required for vessel to pass through opening. Footprint may vary. Contact Tech Service for detailed drawings.

## Rack Layout

Square Rack Layout (P)

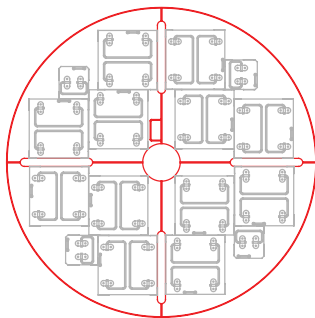

4R9951 Layout (R)

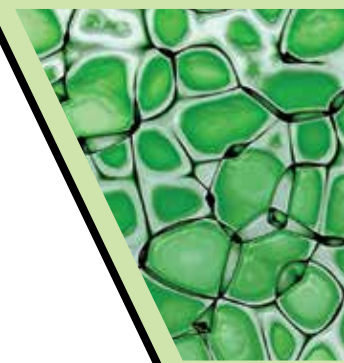
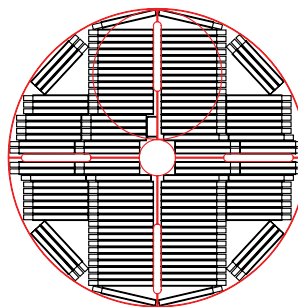

Visit [www.mvebio.com](http://www.mvebio.com) for more information.

© 2021 MVE Biological Solutions reserves the right to discontinue its products, or change the prices, materials, equipment, quality, descriptions, specifications and/or processes to its products at any time without prior notice and with no further obligation or consequence. All rights not expressly stated herein are reserved by us, as applicable.

# MVE High Efficiency 1500 -190°C Series



## Features include

- Dry sample storage
- -190°C top box temperature
- Lowest liftover height
- Largest LN<sub>2</sub> capacity at vapor platform
- 2-tier folding step
- Optional Battery Backup

## Rack Layouts

### Square Rack Layout (P)

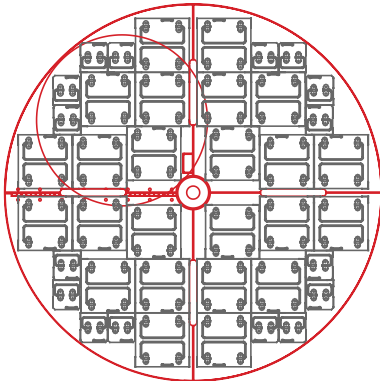

### 4R9951 Layout (R)

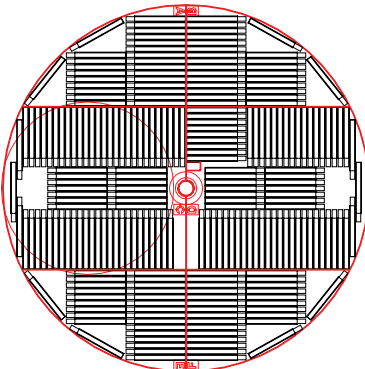

## Featuring the TEC 3000

The MVE 1500 Series -190°C freezers provide cryogenic storage for up to 42,000 1.2 / 2.0 ml vials. Available in three unique sizes, these freezers provide maximum storage density and provide the industry's longest hold time.

	MVE 1536P-190	MVE 1539P-190	MVE 1542R-190						
<b>Maximum Storage Capacity</b>									
1.2 & 2 ml Vials (Internally Threaded)	36,400	39,200	42,000						
Quantity of Large Racks 100 cell boxes	24	24	26						
Quantity of Mini Racks 25 cell boxes	16	16	16						
Number of Shelves per Rack	13	14	14						
<b>Performance</b>									
LN <sub>2</sub> Capacity w/o Inventory L est.	756	797	797						
LN <sub>2</sub> Capacity at Vapor Platform L est.	133	133	133						
<b>Unit Dimensions</b>									
Neck Opening in. (mm)	17.5 (445)	17.5 (445)	17.5 (445)						
Usable Internal Height in. (mm)	28.8 (732)	30.8 (782)	30.8 (782)						
Inner Diameter in. (mm)	38.5 (978)	38.5 (978)	38.7 (983)						
Overall Height w/ AutoFill in. (mm)	61.3 (1556)	63.3 (1608)	63.3 (1608)						
Liftover Height in. (mm)	37.1 (942)	39.2 (995)	39.2 (995)						
Door Width Requirement** Outer Diameter in. (mm)	42.0 (1067)	42.0 (1067)	42.0 (1067)						
Depth of Extended Step in. (mm)	7.9 (201)	7.9 (201)	7.9 (201)						
Weight Empty* lb. (kg)	690 (313)	720 (327)	720 (327)						
Weight Liquid Full* lb. (kg) est.	2037 (924)	2140 (971)	2140 (971)						
<b>Blood Bag Capacities</b>									
	Total Bags	Bags/ Frame	No. Frames	Total Bags	Bags/ Frame	No. Frames	Total Bags	Bags/ Frame	No. Frames
791 OS/U Medsep (25 ml)	2,905	7	415	3,320	8 <sup>†</sup>	415	3,184	8 <sup>†</sup>	398
4R9951 (50 ml)	1,488	6	248	1,736	7	248	1,687	7	241
4R9953 (250 ml)	812	4	203	812	4	203	768	4	192
4R9955 (500 ml)	608	4	152	608	4	152	576	4	144
DF200 (200 ml)	496	4	124	496	4	124	488	4	122
DF700 (700 ml)	256	4	64	256	4	64	264	4	66

**TWO Year Parts Warranty • FIVE Year Vacuum Warranty**

Conforms to MDD 93/42/EEC, the Medical Device Directive for the EU. Freezer systems UL/C-UL Listed.

\* Without inventory

\*\*Minimum width required for vessel to pass through opening. Footprint may vary. Contact Tech Service for detailed drawings.

† Between usable height and clearance. Please refer to specifications.

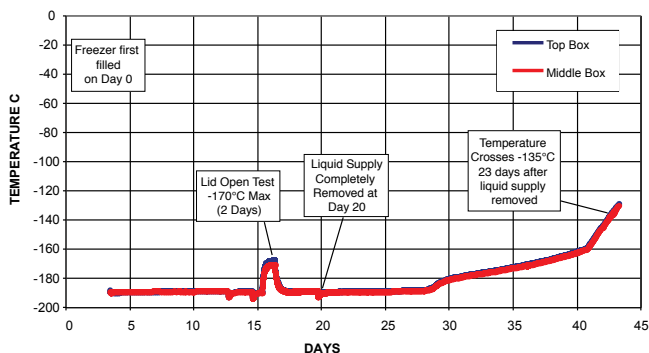

**Temperature Test Graph**

\* Temp Test indicates typical performance of 1500 Series -190°C freezer with full inventory system and factory recommended level settings. Actual performance may vary with atmospheric conditions and usage.



Visit [www.mvebio.com](http://www.mvebio.com) for more information.

© 2021 MVE Biological Solutions reserves the right to discontinue its products, or change the prices, materials, equipment, quality, descriptions, specifications and/or processes to its products at any time without prior notice and with no further obligation or consequence. All rights not expressly stated herein are reserved by us, as applicable.

# MVE High Efficiency 1800 -190°C Series

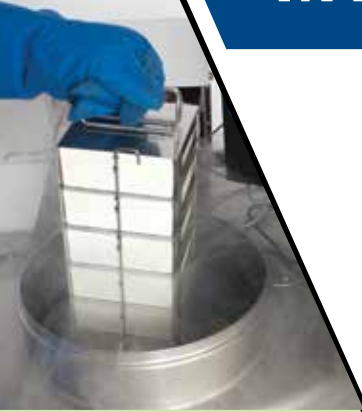

## Features include

- Dry sample storage
- -190°C top box temperature
- Lowest liftover height
- Largest LN<sub>2</sub> capacity at vapor platform
- Two tier folding step
- Optional Battery Backup

## Rack Layouts

### Square Rack Layout (P)

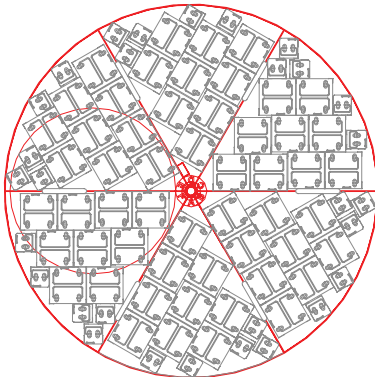

### 4R9951 Layout (R)

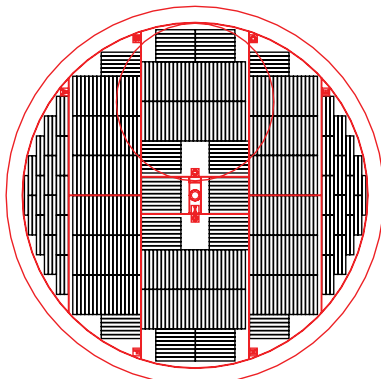

## Featuring the TEC 3000

The MVE 1800 Series -190°C freezers provide cryogenic storage for up to 94,500 1.2 / 2.0 ml vials. These freezers provide maximum storage density and provide the industry's longest hold time.





	MVE 1879P-190	MVE 1881R-190	MVE 1892P-190	MVE 1894R-190								
<b>Maximum Storage Capacity</b>												
1.2 & 2 ml Vials (Internally Threaded)	79,950	81,900	92,250	94,500								
Quantity of Large Racks 100 cell boxes	54	60	54	60								
Quantity of Mini Racks 25 cell boxes	30	12	30	12								
Number of Shelves per Rack	13	13	15	15								
<b>Performance</b>												
LN <sub>2</sub> Capacity w/o Inventory L est.	1540	1521	1736	1731								
LN <sub>2</sub> Capacity at Platform Vapor L est.	290	305	282	300								
<b>Unit Dimensions</b>												
Neck Opening in. (mm)	25.0 (635)	25.0 (635)	25.0 (635)	25.0 (635)								
Usable Internal Height in. (mm)	29.5 (749)	29.2 (742)	34.5 (876)	34.2 (868)								
Inner Diameter in. (mm)	56.0 (1422)	54.8 (1391)	54.8 (1391)	54.8 (1391)								
Overall Height w/AutoFill in. (mm)	68.2 (1732)	68.2 (1732)	73.2 (1860)	73.2 (1860)								
Door Width Requirement**	60.0 (1524)	60.0 (1524)	60.0 (1524)	60.0 (1524)								
Outer Diameter in. (mm)												
Weight Empty* lb. (kg)	1721 (781)	1721 (781)	1721 (781)	1721 (781)								
Weight Liquid Full* lb. (kg) est.	4830 (2191)	4830 (2191)	4875 (2211)	4875 (2211)								
<b>Blood Bag Capacities</b>												
	Total Bags	Bags/ Frame	No. Frames	Total Bags	Bags/ Frame	No. Frames	Total Bags	Bags/ Frame	No. Frames	Total Bags	Bags/ Frame	No. Frames
791 OS/U Medsep (25 ml)	5,866	7	838	5,628	7	804	6,704	8	838	6,432	8	804
4R9951 (50 ml)	2,952	6	492	2,940	6	490	3,936	8	492	3,920	8	490
4R9953 (250 ml)	1,584	4	396	1,608	4	402	1,980	5	396	2,010	5	402
4R9955 (500 ml)	1,104	4	276	1,240	4	310	1,380	5	276	1,550	5	310
DF200 (200 ml)	960	4	240	984	4	246	1,200	5	240	1,230	5	246
DF700 (700 ml)	504	4	126	544	4	136	630	5	126	680	5	136

**TWO Year Parts Warranty • FIVE Year Vacuum Warranty**

Conforms to MDD 93/42/EEC, the Medical Device Directive for the EU. Freezer systems UL/C-UL Listed.

\* Without inventory

\*\*Minimum width required for vessel to pass through opening. Footprint may vary. Contact Tech Service for detailed drawings.

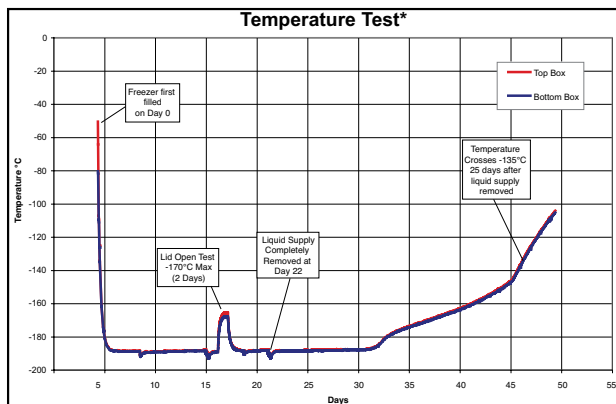

**Temperature Test Graph**

\* Temp Test indicates typical performance of 1800 Series -190°C freezer with full inventory system and factory recommended level settings. Actual performance may vary with atmospheric conditions and usage.



Visit [www.mvebio.com](http://www.mvebio.com) for more information.

© 2021 MVE Biological Solutions reserves the right to discontinue its products, or change the prices, materials, equipment, quality, descriptions, specifications and/or processes to its products at any time without prior notice and with no further obligation or consequence. All rights not expressly stated herein are reserved by us, as applicable.



# MVE Variō® Series Freezers



## Features include

- Approximately 70% operating cost savings compared to leading mechanical freezers (-80 °C)
- Less than 1% of the electricity consumption compared to leading mechanical freezers (-80 °C)
- Completely dry storage area
- Consistent temperature profile, even with lid open
- Improved processing time, minimal increase in temperature when warm samples introduced
- No thermal load; no heat introduced into room and no additional HVAC required
- No more expensive compressors to replace
- Convertible asset: can be retrofitted to expand temperature range to -190
- New touch screen

## Featuring the New MVE Touch Screen

The MVE Variō® Series Freezer is the innovative and energy efficient alternative for ultra low temperature to cryogenic storage. The completely dry sample storage area will maintain a user-defined temperature anywhere between -20°C and -150°C. The MVE Variō Series significantly reduces the possibility of sample contamination via contact with LN<sub>2</sub> while providing the safety margin and consistent temperature profile, even with the lid open, that is associated with LN<sub>2</sub>-based cryogenic storage. The MVE Variō Series is able to provide all of this with less than 1% of the power consumption and approximately 70% overall operating cost savings when compared to the leading mechanical freezers.

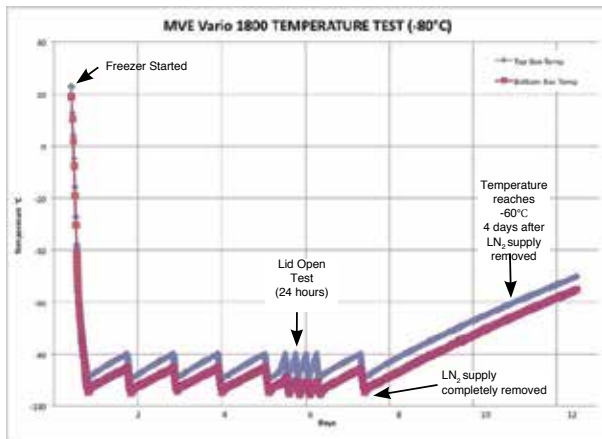

## Temperature Test Graph

\* Temp Test indicates typical performance of MVE Variō Series freezer with full inventory system and factory recommended level settings. Actual performance may vary with atmospheric conditions and usage.

	MVE Variō 1536P	MVE Variō 1539R	MVE Variō 1879P	MVE Variō 1881R	MVE Variō 1894R										
<b>Maximum Storage Capacity</b>															
1.2 & 2 ml Vials (Internally Threaded)	36,400	39,000	79,950	81,900	94,500										
Quantity of Large Racks 100 cell boxes	24	26	54	60	60										
Quantity of Mini Racks 25 cell boxes	16	16	30	12	12										
Number of Shelves per Rack	13	13	13	13	15										
<b>Performance</b>															
Temperature Range	-20°C, -150°C	-20°C, -150°C	-20°C, -150°C	-20°C, -150°C	-20°C, -150°C										
LN <sub>2</sub> Usage at -80°C L/day estimated	9	9	15	15	15										
Power consumption (cont.) W	8	8	8	8	8										
<b>Unit Dimensions</b>															
Neck Opening in. (mm)	17.5 (445)	17.5 (445)	25.0 (635)	25.0 (635)	25.0 (635)										
Usable Internal Height in. (mm)	28.8 (732)	29.3 (745)	29.5 (749)	29.2 (741)	34.2 (868)										
Inner Diameter in. (mm)	38.5 (978)	38.5 (978)	56.0 (1,422)	54.8 (1,391)	54.8 (1,391)										
Overall Height in. (mm)	61.3 (1,556)	61.3 (1,556)	62.1 (1,577)	61.3 (1,556)	66.3 (1,683)										
Door Width Requirement** Outer Diameter in. (mm)	42.0 (1,067)	42.0 (1,067)	60.0 (1,524)	60.0 (1,524)	60.0 (1,524)										
Weight Empty* lb. (kg)	690 (313)	690 (313)	1,606 (728)	1,721 (781)	1,721 (781)										
<b>Blood Bag Capacities</b>	<b>Total Bags</b>	<b>Bags/ Frame</b>	<b>No. Frames</b>	<b>Total Bags</b>	<b>Bags/ Frame</b>	<b>No. Frames</b>	<b>Total Bags</b>	<b>Bags/ Frame</b>	<b>No. Frames</b>	<b>Total Bags</b>	<b>Bags/ Frame</b>	<b>No. Frames</b>	<b>Total Bags</b>	<b>Bags/ Frame</b>	<b>No. Frames</b>
791 OS/U Medsep (25 ml)	3,080	7	440	2,786	7	398	5,866	7	838	5,628	7	804	6,432	8	804
4R9951 (50 ml)	1,488	6	248	1,446	6	241	2,952	6	492	2,940	6	490	3,920	8	490
4R9953 (250 ml)	812	4	203	768	4	192	1,584	4	396	1,608	4	402	2,010	5	402
4R9955 (500 ml)	608	4	152	576	4	144	1,104	4	276	1,240	4	310	1,550	5	310
DF200 (200 ml)	496	4	154	488	4	122	960	4	240	984	4	246	1,230	5	246
DF700 (700 ml)	256	4	64	204	4	66	504	4	126	544	4	136	680	5	136

**TWO Year Parts Warranty • FIVE Year Vacuum Warranty**

Conforms to MDD 93/42/EEC, the Medical Device Directive for the EU. Freezer systems UL/C-UL Listed. (Only Freezers with the Variō Pro Controller)

\* Without inventory

\*\* Minimum width required for vessel to pass through opening. Footprint may vary. Contact Tech Service for detailed drawings.

**Rack Layout**

Square Rack Layout (P)

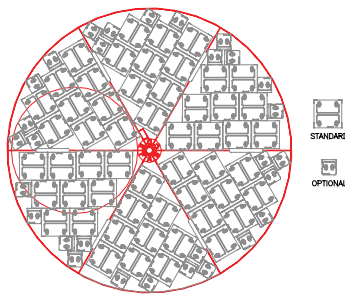

4R9951 Layout (R)

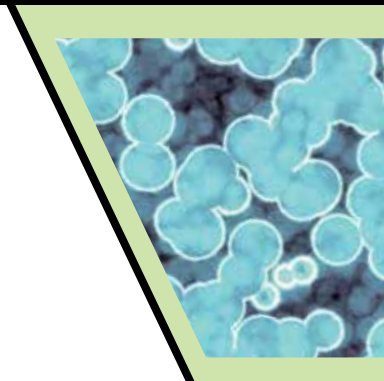
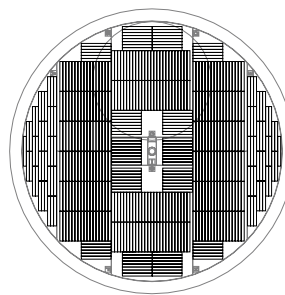

Visit [www.mvebio.com](http://www.mvebio.com) for more information.

© 2021 MVE Biological Solutions reserves the right to discontinue its products, or change the prices, materials, equipment, quality, descriptions, specifications and/or processes to its products at any time without prior notice and with no further obligation or consequence. All rights not expressly stated herein are reserved by us, as applicable.

# MVE Series



## Features include

- Liquid sample storage
- Wide neck opening
- Lowest liftover height
- Largest LN<sub>2</sub> capacity
- Optional Battery Backup

## Rack Layouts

4R9953 Layout

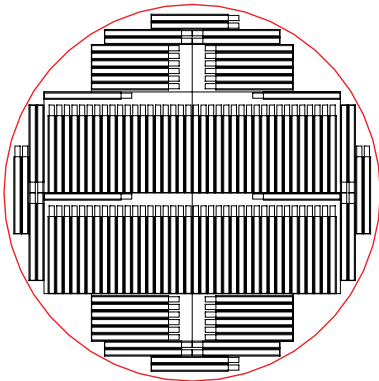

DF700 Layout

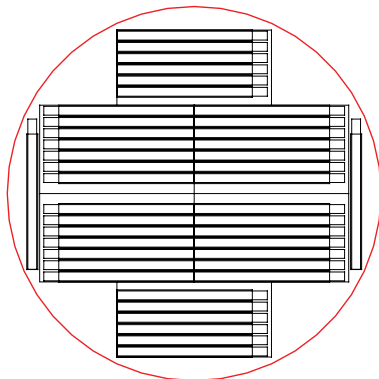

## Featuring the TEC 3000

The MVE Series freezers provide stable cryogenic storage for up to 39,000 1.2 / 2.0 ml vials. These freezers provide maximum storage density and provide the industry's longest hold time. MVE Series are primarily designed for liquid storage.



	MVE 205	MVE 510	MVE 616	MVE 1426	MVE 1839										
<b>Maximum Storage Capacity</b>															
1.2 & 2 ml Vials (Internally Threaded)	5,200	10,400	16,900	26,650	39,000										
Number of Large Racks 100 cell boxes	4	7	12	18	28										
Number of Mini Racks 25 cell boxes	-	4	4	10	8										
Number of Shelves per Rack	13	13	13	13	13										
High Security Straw Capacity (0.5 ml)	19,320	32,760	50,400	79,800	151,200										
Number of Canisters (73 mm)	23	39	60	95	150										
Goblets/Canister : Straws/Goblet	5:168	5:168	5:168	5:168	6:168										
<b>Performance</b>															
LN <sub>2</sub> Capacity w/o Inventory L	95	166	240	388	673										
<b>Unit Dimensions</b>															
Neck Opening in. (mm)	16.00 (406)	20.70 (527)	25.10 (638)	31.75 (806)	39.40 (1002)										
Usable Internal Height in. (mm)	28.9 (735)	30.0 (762)	29.5 (749)	29.3 (745)	33.6 (854)										
Inner Diameter in. (mm)	16.00 (406)	20.70 (527)	25.1 (638)	31.75 (806)	39.40 (1002)										
Overall Height w/AutoFill in. (mm)	46.3 (1176)	46.7 (1185)	45.8 (1161)	46.8 (1188)	54.0 (1372)										
Door W x D Requirement** Outer Diameter in. (mm)	23.6x22.7 (601x577)	30.6x29.7 (778x754)	33.5x34.6 (852x878)	40x41.6 (1017x1056)	46.8x48.9 (1187x1242)										
Weight Empty* lb. (kg)	195 (88)	281 (127)	320 (145)	490 (222)	750 (341)										
Weight Liquid Full* lb. (kg) est.	365 (166)	577 (262)	748 (339)	1181 (536)	1950 (885)										
<b>Blood Bag Capacities</b>															
	Total Bags	Bags/ Frame	No. Frames	Total Bags	Bags/ Frame	No. Frames	Total Bags	Bags/ Frame	No. Frames	Total Bags	Bags/ Frame	No. Frames	Total Bags	Bags/ Frame	No. Frames
791 OS/U Medsep (25 ml)	539	7	77	882	7	126	1,372	7	196	2,226	7	318	3,968	8	496
4R9951 (50 ml)	228	6	38	420	6	70	612	6	102	924	6	154	1,856	8	232
4R9953 (250 ml)	128	4	32	224	4	56	336	4	84	512	4	128	1,010	5	202
4R9955 (500 ml)	96	4	24	160	4	40	248	4	62	424	4	106	770	5	154
DF200 (200 ml)	80	4	20	128	4	32	200	4	50	336	4	84	610	5	122
DF700 (700 ml)	40	4	10	68	4	17	116	4	29	168	4	42	380	5	76

**TWO Year Parts Warranty • FIVE Year Vacuum Warranty**

Conforms to MDD 93/42/EEC, the Medical Device Directive for the EU. Freezer systems UL/C-UL Listed.

\* Without inventory

\*\* Minimum width required for vessel to pass through opening. Footprint may vary. Contact Tech Service for detailed drawings.

Note: The usable height is decreased when using a vapor platform, and storage capacity is reduced when using a sleeve.

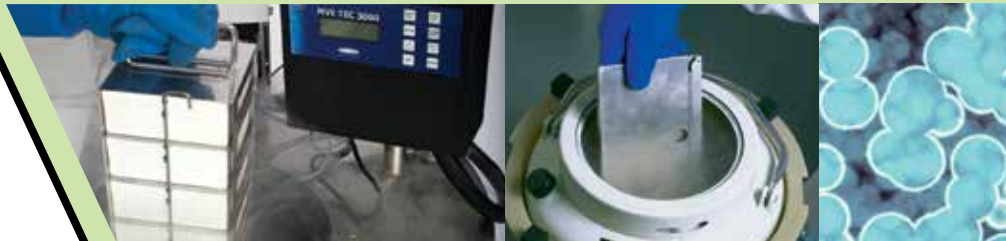

Visit [www.mvebio.com](http://www.mvebio.com) for more information.

© 2021 MVE Biological Solutions reserves the right to discontinue its products, or change the prices, materials, equipment, quality, descriptions, specifications and/or processes to its products at any time without prior notice and with no further obligation or consequence. All rights not expressly stated herein are reserved by us, as applicable.



# MVE 816P-2T-190



## Innovative Inventory System

Two tier storage (with cutout in top tier) allows convenient access to bottom tier.



## Features include

- Vapor phase storage temperature of  $-190^{\circ}\text{C}^*$
- Two tier storage system maximizes capacity while minimizing floor space
- High efficiency design with offset neck for lowest possible  $\text{LN}_2$  consumption
- Optional Battery Backup
- TEC 3000 control system with liquid level control and temperature alarms
- Optional one-or two-tier step

## Featuring the TEC 3000

The MVE 816P-2T-190 freezer is designed with the fertility market in mind. With its unique two-tier tray design, it can hold vials, straws and SUC-1 canisters which are used by leading fertility clinics worldwide. A constant temperature allows for vapor storage throughout the freezer at near liquid nitrogen temperatures. The innovative inventory system incorporates a two level storage arrangement that utilizes an access portal to allow removal of product stored on the lower level.

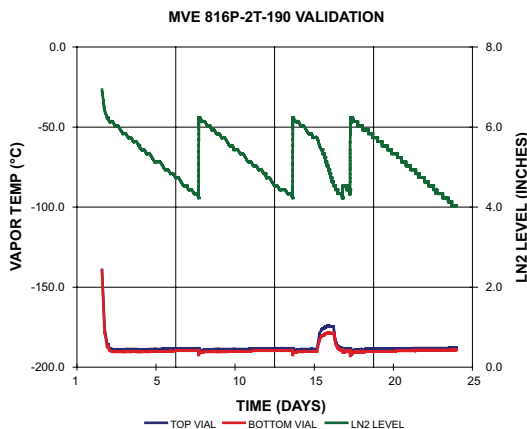

## Temperature Test Graph

\* Temp Test indicates typical performance of MVE 816P-2T-190 freezer with full inventory system and factory recommended level settings. Actual performance may vary with atmospheric conditions and usage.

<b>MVE 816P-2T-190</b>	
<b>Maximum Storage Capacity</b>	
1.2 & 2 ml Vials (Internally Threaded)	10,500
Quantity of Large Racks 100 cell boxes	-
Quantity of Mini Racks 25 cell boxes	-
Number of Shelves per Rack	-
High Security Straw Capacity (0.5 ml)	31,584
Number of Canisters (73 mm)	94
Goblets/Canister : Straws/Goblet	2:168
Number of SUC-1 Canisters (2.5"x2.5"x11)	115
Number of 1.2 ml Vials on Canes	16,560
Number of 2.0 ml Vials on Canes	9,200
Number of 1/2 cc Straws 10/cane	35,650
<b>Performance</b>	
LN, Capacity w/o Inventory L est.	381
LN, Capacity at Platform Vapor L est.	56
<b>Unit Dimensions</b>	
Neck Opening in. (mm)	12.5 (317)
Usable Internal Height in. (mm)	13.0 (330) per level
Inner Diameter in. (mm)	28.70 (728) top tier 27.70 (702) bottom tier
Overall Height with Auto Fill in. (mm)	58.0 (1473)
Door Width Requirement**	32 (813)
Outer Diameter in. (mm)	
Weight Empty* lb. (kg)	475 (215)
Weight Liquid Full* lb. (kg) est.	1155 (524)

**TWO Year Parts Warranty • FIVE Year Vacuum Warranty**

Conforms to MDD 93/42/EEC, the Medical Device Directive for the EU. Freezer systems UL/C-UL Listed.

\* Without inventory

\*\*Minimum width required for vessel to pass through opening. Footprint may vary. Contact Tech Service for detailed drawings.

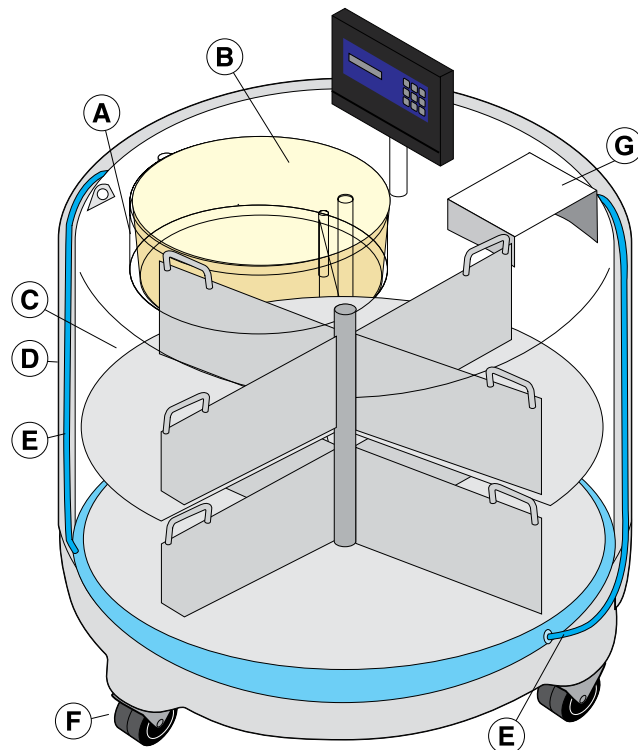

- A Offset neck design minimizes liquid nitrogen consumption
- B Lightweight composite lid is scratch and dent resistant
- C Two level rotating tray provides easy access to samples
- D Stainless steel construction reduces maintenance
- E Annular (internal) filling lines minimizes frost build up and reduces maintenance requirements
- F Durable casters equipped with brakes
- G Lid Stand

**Rack Layout**  
115 SUC Boxes Total

Top Tray

Bottom Tray

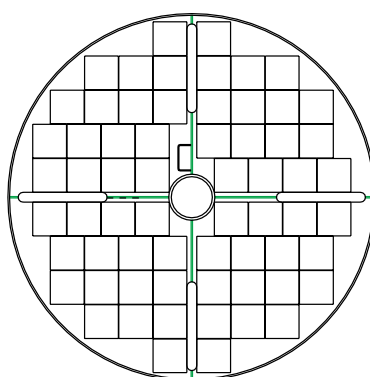
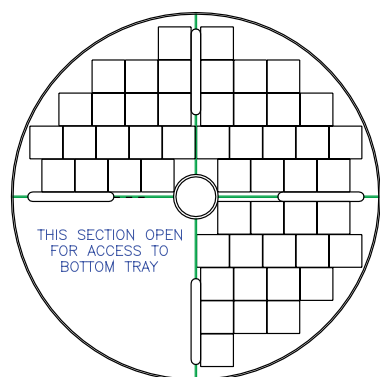

Visit [www.mvebio.com](http://www.mvebio.com) for more information.

© 2021 MVE Biological Solutions reserves the right to discontinue its products, or change the prices, materials, equipment, quality, descriptions, specifications and/or processes to its products at any time without prior notice and with no further obligation or consequence. All rights not expressly stated herein are reserved by us, as applicable.

# MVE Stock Series



## Features include

- Wide neck opening
- Lowest leftover height
- Largest LN<sub>2</sub> Capacity
- Optional Battery Backup



## Featuring the TEC 3000

The MVE Stock Series provides the ultimate in security for the breeding industry and are primarily used to store semen and embryos. The freezers are designed for pull and pack shipment, with a wide neck opening for easy access. Although engineered for liquid storage, most MVE Stock Series can be used to store in vapor.

	MVE 103***	MVE 808	MVE 816P-2T-190	MVE 1318	MVE 1842P-150	MVE 1877P-2T-150
<b>Maximum Storage Capacity</b>						
1.2 & 2 ml Vials (Internally Threaded)	-	11,700	10,500	20,800	-	-
Quantity of Large Racks 100 cell boxes	-	12	-	24	-	-
Quantity of Mini Racks 25 cell boxes	-	4	-	8	-	-
Number of Shelves per Rack	-	9	-	8	-	-
High Security Straw Capacity (0.5 ml)	7,728	37,296	31,584	76,104	-	347,424
Number of Canisters (73 mm)	23	74	94	151	-	517
Goblets/Canister : Straws/Goblet	2:168	3:168	2:168	3:168	2:168	4:168
Number of SUC-1 Canisters (2.5"x2.5"x11)	22	61	115	129	294	539
Number of 1.2 ml Vials on Canes	3,168	8,784	16,560	18,576	42,336	77,616
Number of 2.0 ml Vials on Canes	1,760	4,880	9,200	10,320	23,520	43,120
Number of 1/2 cc Straws 10/cane	6,820	18,910	35,650	39,990	91,140	167,090
<b>Performance</b>						
LN <sub>2</sub> Capacity w/o Inventory L est.	39	230	381	482	872	1456
LN <sub>2</sub> Capacity at Platform Vapor L est.	-	-	56	-	-	250
<b>Unit Dimensions</b>						
Neck Opening in. (mm)	16.0 (406)	25.0 (634)	12.5 (317)	35.5 (901)	25.0 (635)	25.0 (635)
Usable Internal Height in. (mm)	12.0 (305)	22.0 (558)	13.0 (330) per level	18.8 (479)	13.0 (330)	13.0 (330) per tray
Inner Diameter in. (mm)	16.00 (406)	28.30 (720)	28.70 (728) top tier 27.70 (702) bottom tier	39.60 (1007)	56.1 (1425)	56.25 (1429) top and bottom tiers
Overall Height with Auto Fill in. (mm)	16.4 (415)***	53.5 (1359)	58.0 (1473)	58.7 (1491)	51.1 (1296)	64.6 (1639)
Door Width Requirement**	18 (457)	31 (787)	32 (813)	42 (1067)	60 (1524)	60 (1524)
Outer Diameter in. (mm)						
Weight Empty* lb. (kg)	48 (22)	250 (114)	475 (215)	469 (213)	1167 (530)	1721 (781)
Weight Liquid Full* lb. (kg) est.	117 (53)	660 (300)	1155 (524)	1328 (602)	2721 (1234)	4316 (1958)

**TWO Year Parts Warranty • FIVE Year Vacuum Warranty**

Conforms to MDD 93/42/EEC, the Medical Device Directive for the EU. Freezer systems UL/C-UL Listed.

\* Without inventory

\*\* Minimum width required for vessel to pass through opening. Footprint may vary. Contact Tech Service for detailed drawings.

\*\*\* Not available with Auto Fill.



Visit [www.mvebio.com](http://www.mvebio.com) for more information.

© 2021 MVE Biological Solutions reserves the right to discontinue its products, or change the prices, materials, equipment, quality, descriptions, specifications and/or processes to its products at any time without prior notice and with no further obligation or consequence. All rights not expressly stated herein are reserved by us, as applicable.



# MVE CryoCart



## Features include

- Temperature monitor with type T Thermocouple
- Optional Temperature monitor and LN<sub>2</sub> transfer hose connection with plumbing system (manual lever)

MVE CryoCarts are designed for the loading of biological samples into canes, boxes, racks or frames. When used as a portable workbench, the unit will provide a safe and controlled environment for your samples for up to eight hours with the lid open. MVE CryoCart is ideal for transporting large quantities of samples from one tank to another within the same facility.



<b>MVE CryoCart</b>	
<b>Performance</b>	
LN <sub>2</sub> Capacity w/o Inventory To Top of Platform L. est.	39.5
<b>Unit Dimensions</b>	
Overall Length in. (mm)	54.46 (1408)
Overall Width in. (mm)	20.16 (512)
Overall Height in. (mm)	39.5 (1003)
Lift Overall Height in. (mm)	37.2 (944)
Inside Length in. (mm)	41.0 (1041)
Inside Width in. (mm)	13.2 (335)
Inside Depth in. (mm)	15.4 (391)
Platform Height in. (mm)	4.5 (114)
Footprint in. (mm)	17.6x51.7 (447x1313)
Weight Empty lb. (kg) est.	195 (88)
Weight w/LN <sub>2</sub> Filled to Top of Platform lb. (kg) est.	266 (121)
Number of Racks (15-2)	2

**90 Days Parts Warranty • One Year Vacuum Warranty  
Not designed for long-term storage.**



# MVE Research Dewars



The MVE Research Dewars are developed specifically for easy and safe handling of liquid nitrogen and samples within facilities. These units are vacuum insulated for superior thermal performance and long hold times.

## Features include

- All stainless steel construction
- Optional insulated lid (cork & cover is not included)
- Wide mouth for easy access
- Convenient carrying handle (except .5L)
- Meets laboratory safety requirements that prohibit glass lined dewars

	RD-6	RD-3	RD-2	RD-1	RD-1W	RD-0.5
<b>Performance</b>						
<b>LN<sub>2</sub> Capacity L est.</b>	6	3	2	1	1	0.5
<b>Handle</b>	yes	yes	yes	yes	yes	no
<b>Unit Dimensions</b>						
<b>Neck Opening in. (mm)</b>	7.3 (185)	7.3 (185)	3.9 (99)	3.3 (84)	3.9 (99)	2.6 (66)
<b>Inner Diameter in. (mm)</b>	7.3 (185)	7.3 (185)	3.9 (99)	3.3 (84)	3.9 (99)	2.6 (66)
<b>Outside Diameter in. (mm)</b>	7.8 (198)	7.8 (198)	4.8 (122)	4.3 (109)	4.8 (122)	3.4 (86)
<b>Usable Internal Height in. (mm)</b>	10.6 (269)	6.3 (160)	7.1 (180)	6.2 (157)	6.1 (155)	7.1 (180)
<b>Overall Height in. (mm)</b>	11.8 (300)	7.5 (191)	12.3 (312)	9.1 (231)	7.0 (178)	8.0 (203)
<b>Weight Empty* lb. (kg)</b>	4.4 (2.0)	3.3 (1.5)	1.8 (0.8)	1.1 (0.5)	1.1 (0.5)	0.7 (0.3)
<b>Weight Liquid Full* lb. (kg)</b>	15.0 (6.8)	8.6 (3.9)	5.3 (2.4)	2.9 (1.3)	2.9 (1.3)	1.5 (0.7)
<b>NER without Cover Days</b>	0.4	0.2	0.1	0.1	0.2	0.1

## 90-Day Warranty

\*Estimated weights



Visit [www.mvebio.com](http://www.mvebio.com) for more information.



© 2021 MVE Biological Solutions reserves the right to discontinue its products, or change the prices, materials, equipment, quality, descriptions, specifications and/or processes to its products at any time without prior notice and with no further obligation or consequence. All rights not expressly stated herein are reserved by us, as applicable.

# MVE CryoSystem 6000 Full Auto



## Features include

- Fully automatic LN<sub>2</sub> level control and temperature monitoring
- Designed for liquid storage; can be used as vapor storage
- 17 user-defined audio / visual alarms
- Convenient placement of cork/cover for easy sample insertion and retrieval
- Controller post tilted for convenient LCD viewing
- Improved efficiency
- Transportable in case of emergencies or in the event of natural disasters
- Includes six racks, transfer hose, and roller base



## Featuring the TEC 3000

The MVE CryoSystem 6000 Full Auto combines the compact efficiency of aluminum dewars with the monitoring and auto fill features of the TEC3000 control system. The differential pressure-based level control allows this unit to easily be used for liquid or vapor storage. The TEC3000 continually monitors and records temperature and LN<sub>2</sub> levels, auto filling when needed, and providing audio/visual alarms with remote connectivity when necessary. The enhanced safety factor of not having to manually fill this unit also helps maintain a consistent temperature profile.

The CryoSystem 6000 Full Auto provides the convenience and security of high capacity stainless steel freezers for your average sized sample collection at a fraction of the price.



## CryoSystem 6000 FA

### Performance

LN <sub>2</sub> Capacity w/o Inventory L est.	175.0
Static Evaporation Rate* L/day	2.5

### Unit Dimensions

Neck Opening in. (mm)	8.5 (216)
Overall Height with Auto Fill in. (mm)	37.9 (963)
Outer Diameter in. (mm)	26.5 (673)
Weight Empty lb. (kg)	156 (70.7)
Weight Full lb. (kg) est.	478 (216.8)

### Maximum Storage Capacity

Box Size in.	2	3	3.75
Number of Racks	6	6	6
Number of vials 1.2 & 2 ml vials 100/box est.	6,000	4,200	3,000
Boxes per Rack	10	7	5

\* Static evaporation rate and static holding time are nominal. Actual rate and holding time will be affected by the nature of container use, atmospheric conditions, and manufacturing tolerances.

**TWO Year Parts Warranty • THREE Year Vacuum Warranty**

Conforms to MDD 93/42/EEC, the Medical Device Directive for the EU.

### Tank Features

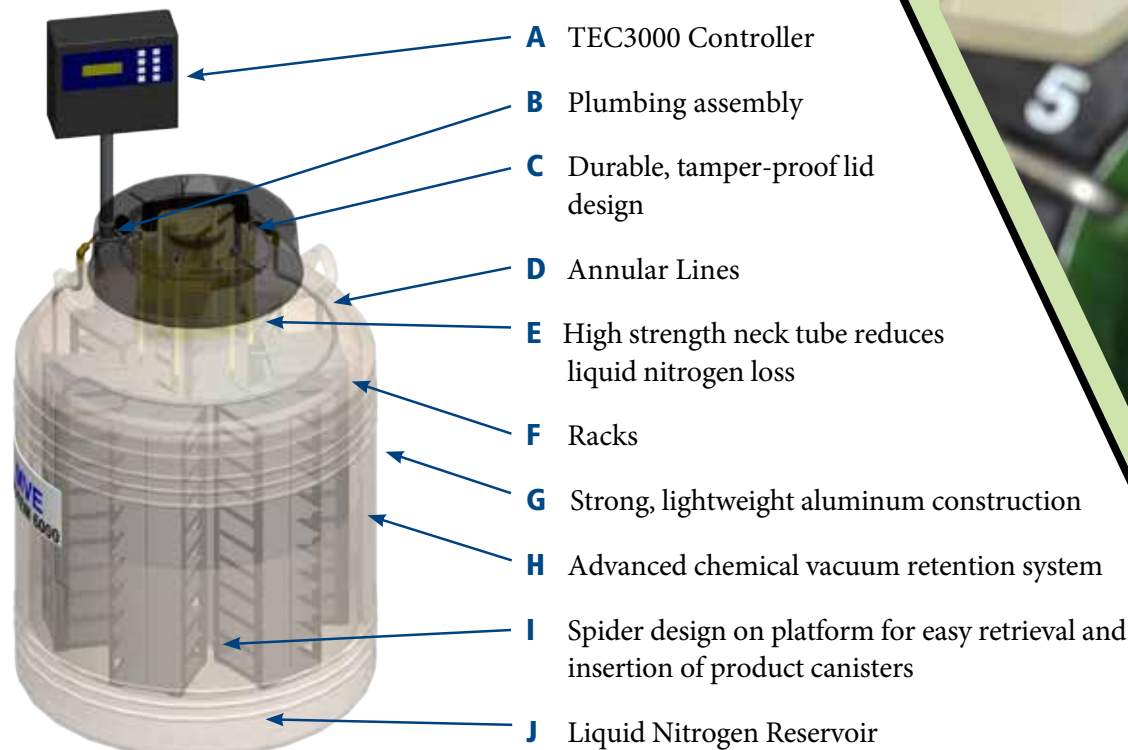

Visit [www.mvebio.com](http://www.mvebio.com) for more information.

© 2021 MVE Biological Solutions reserves the right to discontinue its products, or change the prices, materials, equipment, quality, descriptions, specifications and/or processes to its products at any time without prior notice and with no further obligation or consequence. All rights not expressly stated herein are reserved by us, as applicable.

# MVE CryoSystem Series

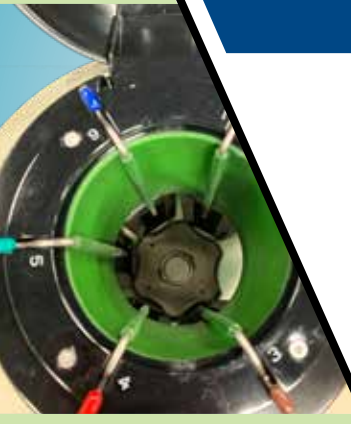

The MVE CryoSystem Series combines the benefits of low nitrogen consumption with mid-range vial capacity to meet the diverse needs of today's professionals worldwide. The lightweight and low-space demands of these containers make them the most economical units in their class.

## Features include

- Designed for large capacity storage
- Low liquid nitrogen consumption
- Convenient lightweight package

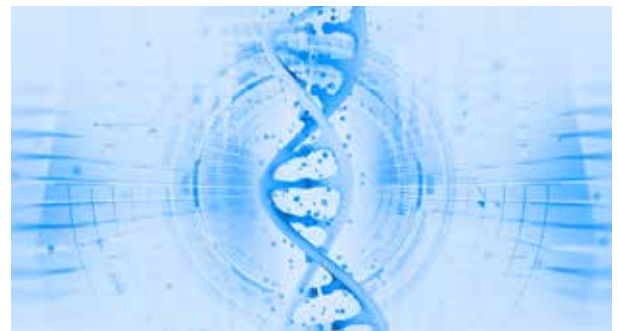
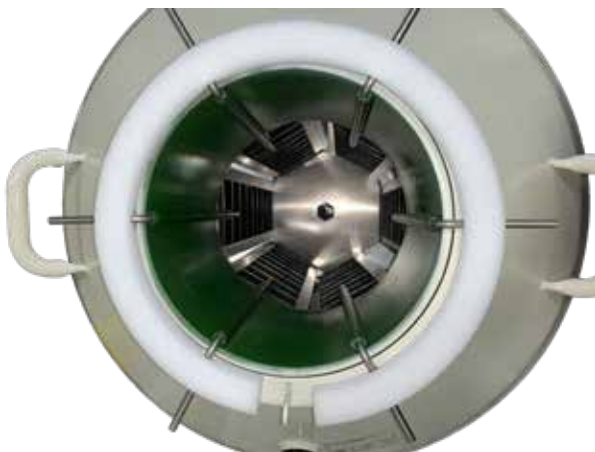



	CryoSystem 750	CryoSystem 2000	CryoSystem 4000	CryoSystem 6000
<b>Maximum Storage Capacity</b>				
Number of Racks	6	4	4	6
Number of 1.2 & 2.0 ml vials 100/box	-	2,000	4,000	6,000
Number of 1.2 & 2.0 ml vials 25/box	750	-	-	-
Boxes per Rack	5	5	10	10
<b>Performance</b>				
LN <sub>2</sub> Capacity w/o Inventory L est.	47.4	61.0	121.0	175.0
LN <sub>2</sub> Capacity w/Inv. L est.	45	51	111	150
Static Evaporation Rate* L/day	0.39	0.85	0.99	0.99
Working Duration** Full Days	76	38	70	104
<b>Unit Dimensions</b>				
Neck Opening in. (mm)	5.0 (127)	8.5 (216)	8.5 (216)	8.5 (216)
Overall Height in. (mm)	26.50 (673)	27.25 (692)	38.00 (965)	37.9 (963)
Outer Diameter in. (mm)	20 (508)	22 (559)	22 (559)	26.5 (673)
Weight Empty lb. (kg)	42 (19.0)	58 (26.3)	81 (36.7)	103 (46.7)
Weight Full lb. (kg)	126 (57)	182 (82.5)	300 (136)	425 (193)

\* Static evaporation rate and static holding time are nominal. Actual rate and holding time will be affected by the nature of container use, atmospheric conditions, and manufacturing tolerances.

\*\* Working Duration is an arbitrary reference, to estimate container performance under normal operating conditions in liquid storage. Actual working time may vary due to current atmospheric conditions, container history, manufacturing tolerances and patterns of use.

**TWO Year Parts Warranty • THREE Year Vacuum Warranty**

Conforms to MDD 93/42/EEC, the Medical Device Directive for the EU.

## Tank Features

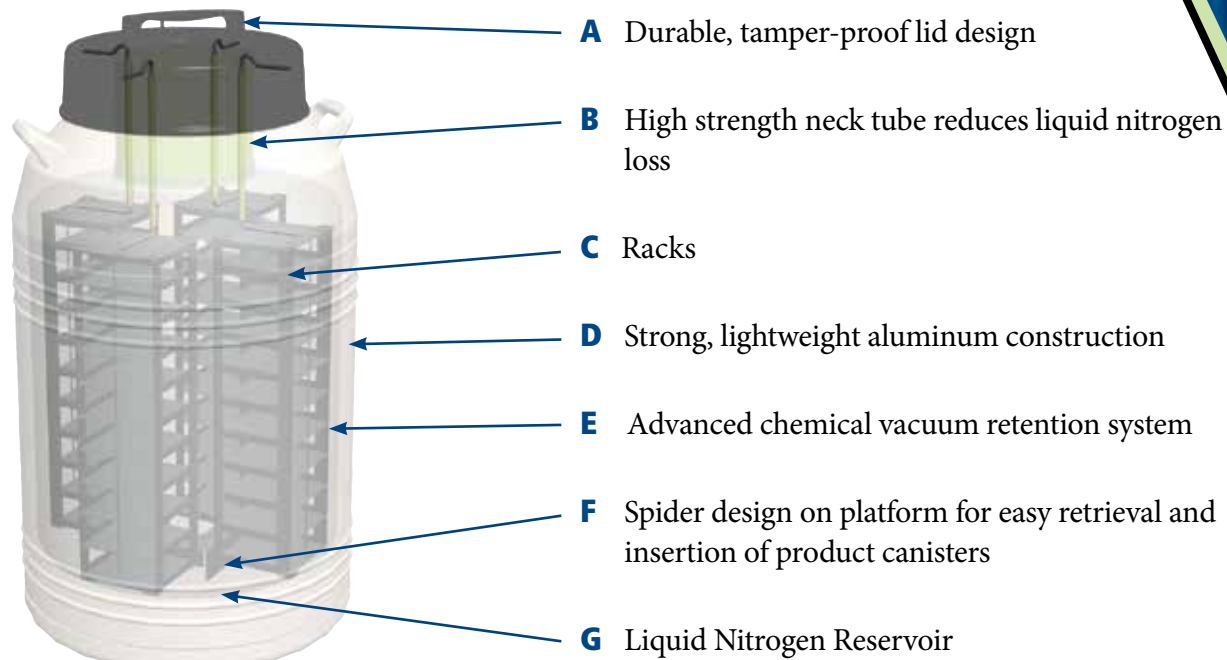

Visit [www.mvebio.com](http://www.mvebio.com) for more information.



© 2021 MVE Biological Solutions reserves the right to discontinue its products, or change the prices, materials, equipment, quality, descriptions, specifications and/or processes to its products at any time without prior notice and with no further obligation or consequence. All rights not expressly stated herein are reserved by us, as applicable.



# MVE Lab Series



## Features include

- Designed for efficient storage of liquid nitrogen
- Low liquid nitrogen consumption
- Convenient lightweight package



The Lab Series cryogenic liquid dewars are named for their acceptance in laboratories and medical facilities worldwide. These high-efficiency, super insulated dewars are the most convenient, economical way to store and dispense liquid nitrogen. Many lab units can be fitted with pouring spouts, pressurized dispensing devices or dippers to aid in the transfer of liquid nitrogen.

	LAB 4	LAB 5	LAB 10	LAB 20	LAB 30	LAB 47	LAB 50
<b>Performance</b>							
<b>LN<sub>2</sub> Capacity</b> L est.	4	5	10	20	32	47	50
<b>Static Evaporation Rate*</b> L/day	0.19	0.15	0.18	0.18	0.22	0.39	0.49
<b>Unit Dimensions</b>							
<b>Neck Opening</b> in. (mm)	1.4 (35)	2.18 (55.4)	2.18 (55.4)	2.18 (55.4)	2.5 (64)	5.0 (127)	2.5 (64)
<b>Overall Height</b> in. (mm)	16.8 (426)	18.2 (462)	21.5 (546)	24.5 (622)	24.0 (610)	26.5 (673)	30.5 (775)
<b>Usable Height</b> in. (mm)	7.8 (198)	10.5 (266)	13.5 (343)	13.7 (348)	14.9 (378)	16.8 (427)	22.0 (559)
<b>Outer Diameter</b> in. (mm)	7.3 (185)	8.8 (222)	10.3 (260)	14.5 (368)	17.0 (432)	20.0 (508)	17.0 (432)
<b>Internal Diameter</b> in. (mm)	5.5 (139)	6.5 (165)	8.3 (210)	11.4 (289)	14.0 (356)	16.5 (419)	14.0 (356)
<b>Weight Empty</b> lb. (kg)	6 (2.7)	8 (4)	12 (5.4)	19 (9)	25 (11.4)	42 (19)	31 (14)
<b>Weight Full</b> lb. (kg)	13 (6)	17 (8)	31 (14)	55 (25)	82 (37.2)	120.4 (54.6)	120 (54.4)

\* Static evaporation rate and static holding time are nominal. Actual rate and holding time will be affected by the nature of container use, atmospheric conditions, and manufacturing tolerances.

Note: The Lab Series is designed for liquid storage.

**TWO Year Parts Warranty • FIVE Year Vacuum Warranty**

Conforms to MDD 93/42/EEC, the Medical Device Directive for the EU.

## Tank Features

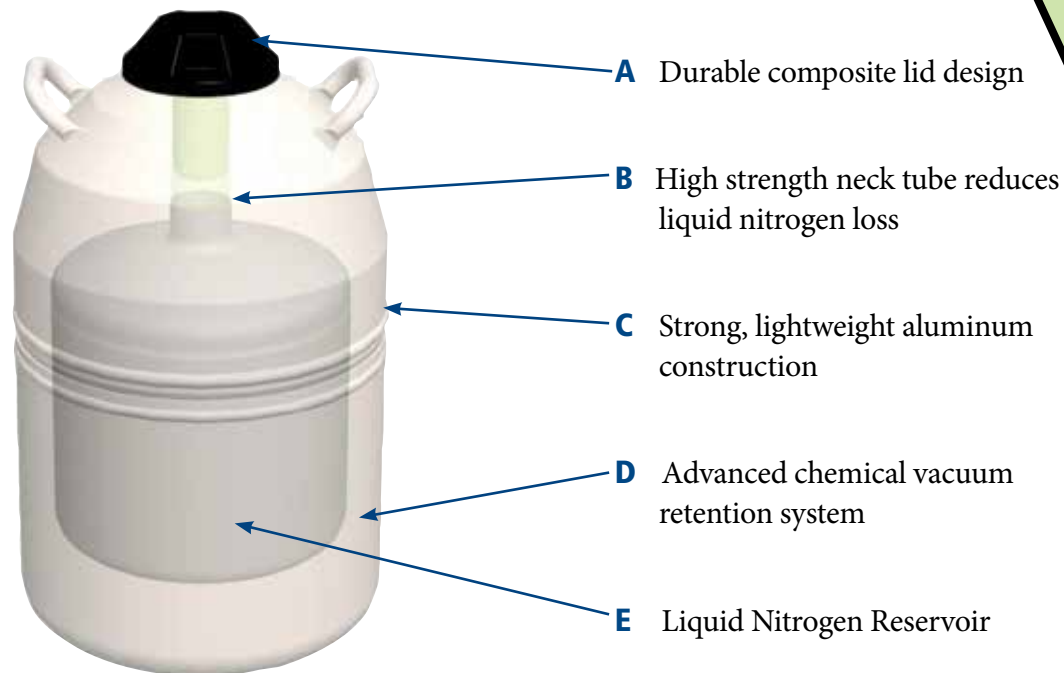

Visit [www.mvebio.com](http://www.mvebio.com) for more information.

© 2021 MVE Biological Solutions reserves the right to discontinue its products, or change the prices, materials, equipment, quality, descriptions, specifications and/or processes to its products at any time without prior notice and with no further obligation or consequence. All rights not expressly stated herein are reserved by us, as applicable.

# MVE SC Series



## Features include

- Designed for small capacity storage needs
- Low liquid nitrogen consumption
- Convenient lightweight package
- SC 20/20 Signature includes Bend Don't Break™ durability feature

## Tank Features

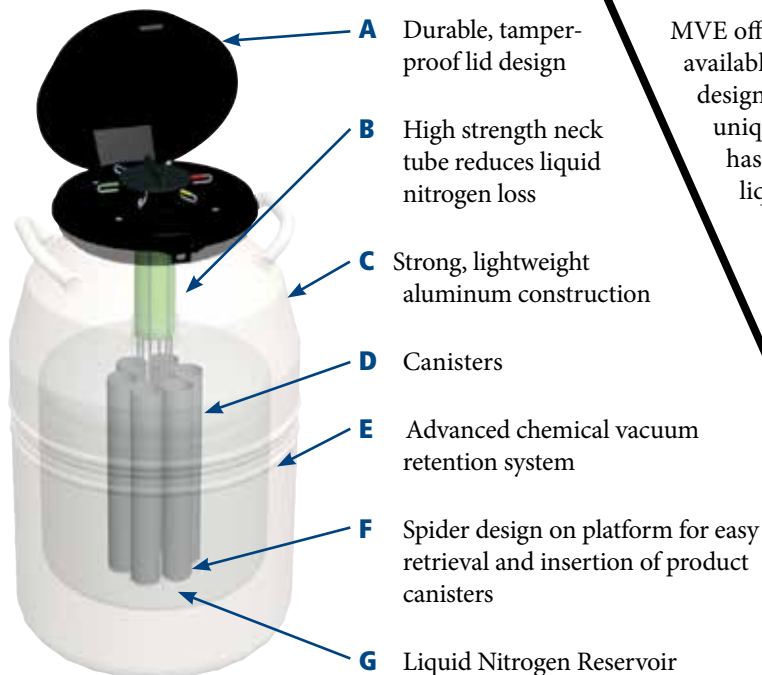

MVE offers the widest range of compact aluminum storage tanks available on the market today. Over the past 50 years, our product designs have improved through end-user input and evolved into a unique selection of units. The SC Series is designed for the user who has small capacity needs, but requires long-term storage and low liquid nitrogen consumption in a convenient lightweight package.

	SC 3/3	SC 8/5	SC 11/7	SC 20/20 Signature	SC 33/26	SC 36/32	Super 2
<b>Maximum Storage Capacity</b>							
<b>Number of Canisters</b>	6	6	6	6	6	6	6
<b>Number of 1/2 cc Straws 10/ cane</b>	-	-	660	660	660	660	660
<b>Number of 1/2 cc Straws 1 Level Bulk</b>	440	440	879	879	879	879	879
<b>Number of 1.2 &amp; 2.0 ml vials 5/cane</b>	-	-	210	210	150	150	210
<b>Performance</b>							
<b>LN<sub>2</sub> Capacity w/o Inventory L est.</b>	3.6	8.4	11.0	20.5	33.0	36.5	24.5
<b>Static Evaporation Rate* L/ day</b>	0.13	0.15	0.16	0.085	0.13	0.10	0.085
<b>Working Duration** Full Days</b>	17	35	43	150	182	224	180
<b>Unit Dimensions</b>							
<b>Neck Opening in. (mm)</b>	2.18 (55.4)	2.18 (55.4)	2.18 (55.4)	2.18 (55.4)	2.18 (55.4)	2.18 (55.4)	2.18 (55.4)
<b>Overall Height in. (mm)</b>	16.0 (406)	18.5 (470)	21.6 (549)	26.0 (660)	25.9 (657)	27.2 (690)	28.2 (716)
<b>Outer Diameter in. (mm)</b>	8.7 (222)	10.2 (260)	10.2 (260)	14.5 (368)	18.2 (464)	18.2 (464)	14.5 (368)
<b>Canister Height in. (mm)</b>	5.0 (127)	5.0 (127)	11.0 (279)	11.0 (279)	11.0 (279)	11.0 (279)	11.0 (279)
<b>Canister Diameter in. (mm)</b>	1.65 (41.9)	1.65 (41.9)	1.65 (41.9)	1.65 (41.9)	1.65 (41.9)	1.65 (41.9)	1.65 (41.9)
<b>Weight Empty lb. (kg)</b>	8 (3.6)	12 (5.3)	17 (7.7)	22.5 (10.2)	34 (15.4)	34 (15.4)	26.5 (12)
<b>Weight Full lb. (kg)</b>	14.4 (6.5)	27.0 (12.1)	36.6 (16.6)	58.99 (26.7)	93.4 (42.4)	100.0 (44.8)	68.4 (31)

\* Static evaporation rate and static holding time are nominal. Actual rate and holding time will be affected by the nature of container use, atmospheric conditions, and manufacturing tolerances.

\*\* Working Duration is an arbitrary reference, to estimate container performance under normal operating conditions in liquid storage. Actual working time may vary due to current atmospheric conditions, container history, manufacturing tolerances and patterns of use.

**TWO Year Parts Warranty • FIVE Year Vacuum Warranty**

Conforms to MDD 93/42/EEC, the Medical Device Directive for the EU.



Visit [www.mvebio.com](http://www.mvebio.com) for more information.

© 2021 MVE Biological Solutions reserves the right to discontinue its products, or change the prices, materials, equipment, quality, descriptions, specifications and/or processes to its products at any time without prior notice and with no further obligation or consequence. All rights not expressly stated herein are reserved by us, as applicable.



# MVE XC Series



## Features include

- Designed for large capacity storage
- Low liquid nitrogen consumption
- Convenient lightweight package
- XC 20 Signature includes Bend Don't Break™ & Semen Safe™ durability features

MVE XC Series tanks have capacities ranging from 700–5000 straws, and 210 to over 1000 vials. Manufactured to a world class level of excellence and backed by an industry-leading 5-year vacuum warranty, these durable, lightweight units can be relied on to perform in the most demanding of environments.

## Tank Features

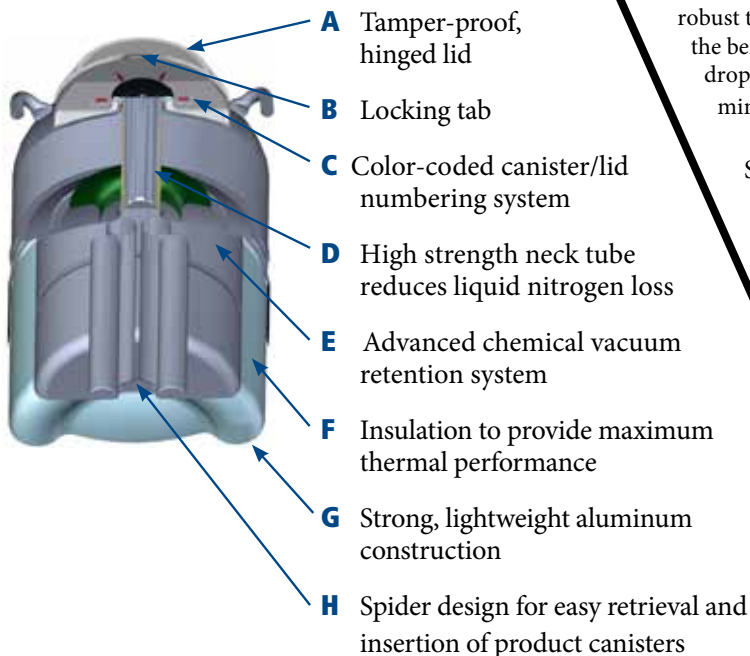

### BEND DON'T BREAK™ (Patent Pending)

After 2 years in concept testing, the new XC 20 Signature includes a new top head shape which deforms in order to absorb G-force damage to the neck area. This increases the durability of the XC 20 Signature and will make the tank more robust to MINIMIZE the damage from mishandling and transport. Although the bend concept allows for visible outside evidence that has been tipped or dropped during transport, it will be more resilient and less likely to break, minimizing the chances of product loss.

### SEMEN SAFE™

With extensive testing, the new XC 20 Signature will include a stronger composite neck that is 20% stronger than the old design. This feature will allow the neck to be less susceptible to G-force damage from mishandling and transport in order to increase the durability of the XC 20 Signature. When combined with BEND DON'T BREAK™, it should minimize semen losses, which are the result of transport damage. While we've maintained the "form, fit, and function" of the MVE 20 Millennium design, SEMEN SAFE™ increases the durability of our tanks.



	XC 20 Signature	XC 21/6	XC 22/5	XC 32/8	XC 33/22	XC 34/18	XC 34/18 Plus	XC 43/28	XC 47/11- 65Q	XC 47/11-6	XC 47/11- 10
<b>Maximum Storage Capacity</b>											
Number of Canisters	6	9	6	9	6	6	6	6	6 sq.	6	10
Number of 1/2 cc Straws 10/cane	660	-	2,400	2,520	1,260	2,100	2,100	1,260	-	3,900+	3200
Number of 1/2 cc Straws 1 Level Bulk	879	3,870	3,666	3,960	1,764	3,300	3,300	1,764	-	6,200	5,000
Number of 1/2 cc Straws 2 Level Bulk	1,680	-	-	-	-	-	-	-	-	-	-
Number of 1.2 & 2.0 ml vials 5/cane	210	-	810	855	360	630	630	360	-	1,320	1,050
Number of Racks 25 Vials	-	-	-	-	-	-	-	-	750	-	-
<b>Performance</b>											
LN <sub>2</sub> Capacity w/o Inven- tory L est.	20.5	21.0	22.4	32.0	33.4	34.8	67.5	42.2	47.4	47.4	47.4
LN <sub>2</sub> Capacity w/o Inven- tory Below Spider L est.	-	-	-	-	-	-	32.7	-	-	-	-
Static Evaporation Rate* L/day	0.090	0.35	0.35	0.35	0.14	0.18	0.40	0.14	0.39	0.39	0.39
Working Duration** Full Days	142	38	40	57	154	123	136	193	76	76	76
<b>Unit Dimensions</b>											
Neck Opening in. (mm)	2.18 (55.4)	3.50 (89)	3.81 (97)	3.81 (97)	2.75 (70)	3.50 (89)	3.50 (89)	2.75 (70)	5.00 (127)	5.00 (127)	5.00 (127)
Overall Height in. (mm)	26.0 (660)	17.2 (438)	22.0 (559)	21.5 (546)	26.0 (660)	26.6 (675)	37.5 (952)	26.4 (670)	26.5 (673)	26.5 (673)	26.5 (673)
Overall Inner Height in. (mm)	-	-	-	-	-	-	33.5 (850)	-	-	-	-
Outer Diameter in. (mm)	14.5 (368)	18.2 (464)	14.5 (368)	18.2 (464)	18.2 (464)	18.2 (464)	18.2 (464)	20.0 (508)	20.0 (508)	20.0 (508)	20.0 (508)
Canister Height in. (mm)	11/5 (279/127)	5 (127)	11 (279)	11 (279)	11 (279)	11 (279)	11 (279)	11 (279)	-	11 (279)	11 (279)
Canister Diameter in. (mm)	1.69/1.65 (42.9/41.9)	2.59 (68)	3.09 (79)	2.62 (67)	2.22 (56)	2.8 (71)	2.81 (71)	2.22 (56)	-	4.00 (102)	2.81 (71)
Distance: Platform to Top of Neck in. (mm)	-	-	-	-	-	-	21 (533)	-	-	-	-
Weight Empty lb. (kg)	22 (10)	24 (10.9)	26 (11.8)	30 (13.6)	34 (15.4)	34 (15.4)	45.9 (20.8)	36 (16.4)	42 (19.0)	42 (19.0)	42 (19.0)
Weight Full lb. (kg)	58.4 (26.5)	61.4 (27.9)	66.0 (30)	87.0 (39.5)	94.0 (42.5)	96.0 (43.5)	104.4 (47.3)	111.0 (50.5)	120.4 (54.6)	120.4 (54.6)	120.4 (54.6)

\* Static evaporation rate and static holding time are nominal. Actual rate and holding time will be affected by the nature of container use, atmospheric conditions, and manufacturing tolerances.

\*\* Working Duration is an arbitrary reference, to estimate container performance under normal operating conditions in liquid storage. Actual working time may vary due to current atmospheric conditions, container history, manufacturing tolerances and patterns of use.

**TWO Year Parts Warranty • FIVE Year Vacuum Warranty**

Conforms to MDD 93/42/EEC, the Medical Device Directive for the EU.

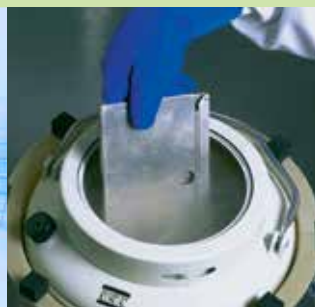
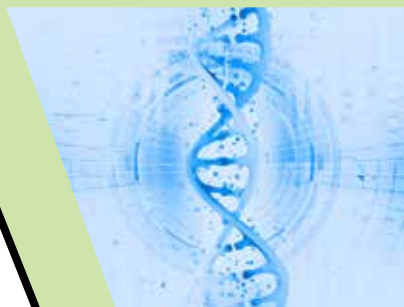

Visit [www.mvebio.com](http://www.mvebio.com) for more information.

© 2021 MVE Biological Solutions reserves the right to discontinue its products, or change the prices, materials, equipment, quality, descriptions, specifications and/or processes to its products at any time without prior notice and with no further obligation or consequence. All rights not expressly stated herein are reserved by us, as applicable.

# MVE Doble Series

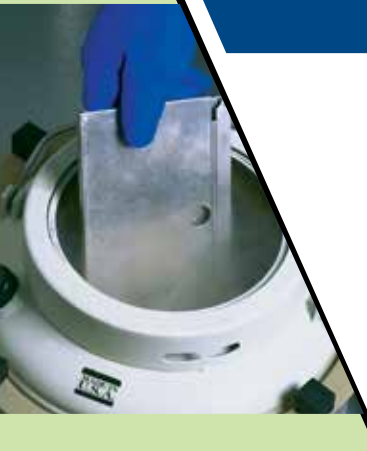

## Features include

- MVE Protective Shipping Containers are recommended
- Protective shipping containers ensure upright shipping
- Liquid and vapor storage options
- Low liquid nitrogen consumption
- Convenient lightweight package
- **CHARGES IN TWO HOURS\***



## Tank Features

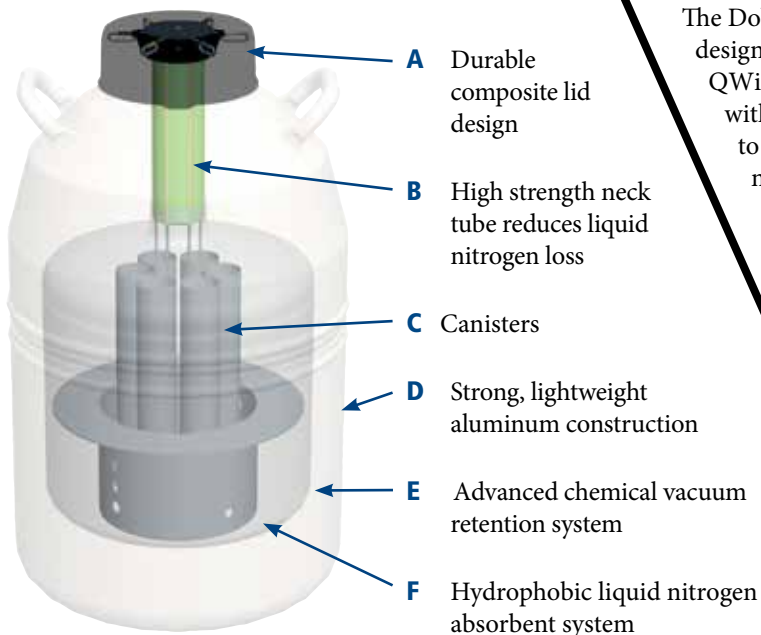

## Featuring Advanced QWick™ Charge Technology

The Doble Series cryogenic liquid dewars are the first units to be designed for both vapor shipment and liquid storage. The Doble QWick Series utilizes an absorbent wicking material that charges with liquid nitrogen in two hours. \*New/warm tanks still need to be filled with LN<sub>2</sub> and allowed to sit 24 hours to achieve maximum hold time. When a tank is already cold, the Advanced QWick Charge technology will apply, providing the capacity for same-day vapor shipping. A unique absorbent layer in the base of the storage tanks enables them to be charged with nitrogen and employed as dry shippers with hold times of up to 21 days. Once at the final destination, the tanks can be filled with liquid and used for long term storage, therefore avoiding the need for return shipments.

	Doble 11	Doble 20	Doble 22	Doble 28	Doble 34	Doble 47	Doble 47-10
<b>Maximum Storage Capacity</b>							
Number of Canisters	6	6	6	6	6	6	10
No. of 1/2 cc Straws 10/cane	660	660	2400	2,400	2,100	4,500	3,500
Vial Capacity	210	210	810	810	630	1,320	1,050
<b>Performance (Hold Time overrides NER specifications)</b>							
LN <sub>2</sub> Capacity w/o Inventory L est.	10.0	18.5	20.0	28.0	32.0	46.0	46.0
Vapor Capacity L	3.1	4.2	5.5	8.4	7.9	6.0	6.0
Static Evaporation Rate L/day	0.17	0.10	0.35	0.35	0.20	0.40	0.40
Working Duration days for liquid	37	116	40	50	110	74	72
Working Duration days for vapor	17	21	18	21	21	21	21
<b>Unit Dimensions</b>							
Neck Opening in (mm)	2.18 (55)	2.18 (55)	3.81 (97)	3.81 (97)	3.50 (89)	5.00 (127)	5.00 (127)
Overall Height in (mm)	21.6 (549)	25.5 (647)	22 (559)	22 (559)	26.6 (676)	26.5 (673)	26.5 (673)
Outside Diameter in (mm)	10.2 (260)	14.5 (368)	14.5 (368)	18.2 (462)	18.2 (462)	20.0 (508)	20.0 (508)
Canister Height in (mm)	11 (279)	11 (279)	11 (279)	11 (279)	11 (279)	11 (279)	11 (279)
Canister Diameter in (mm)	1.65 (42)	1.65 (42)	1.65 (42)	1.65 (42)	1.65 (42)	1.65 (42)	1.65 (42)
Weight Empty lb. (kg)	14.5 (6.6)	23 (10.4)	23.8 (10.7)	33 (15.0)	34.5 (15.6)	41 (18.5)	41 (18.5)
Weight Charged vapor lb. (kg)	19.5 (8.8)	30.3 (13.7)	35 (15.8)	47 (21.3)	47.9 (21.7)	54.6 (24.7)	54.6 (24.7)
Weight Full liquid lb. (kg)	32 (14.5)	56 (25.4)	68 (30.8)	89 (40.4)	92 (41.7)	117 (53.1)	117 (53.1)
Protective Shipping Container Part No.	20750519	11912460	11912460	11930861	20863878	14035731	14035731

**TWO Year Parts Warranty • THREE Year Vacuum Warranty** | Conforms to MDD 93/42/EEC, the Medical Device Directive for the EU.

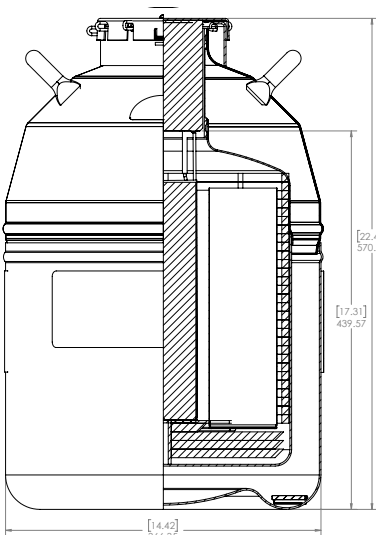

**FEATURES**

- LOCKABLE CORK AND COVER
- CHARGES IN 2 HOURS\*
- OPTIONAL CENTER CANISTER AND INSERT TO EXTEND HOLD TIME

**PERFORMANCE**

- ABSORBED LN<sub>2</sub> CAPACITY ----- 5.5 LITERS
- STATIC EVAPORATION RATE (EXCLUDING INVENTORY) ----- 0.35 L/DAY (HOLD TIME OVERRIDES NER SPECIFICATION)
- STATIC HOLD TIME\*\* (EXCLUDING INVENTORY) ----- 18 DAYS

**UNIT DIMENSIONS**

- NECK OPENING inch(mm) ----- 3.8 (96.7)
- OVERALL HEIGHT (TOP OF LID) inch(mm) ----- 22.0 (559)
- OUTSIDE DIAMETER inch(mm) ----- 14.5 (368)
- EMPTY WEIGHT LBS(kg) ----- 23.3 (10.5) (+/- 5% TYPICAL)
- CHARGED WEIGHT (EXCLUDING INVENTORY)\*\*\* LBS(kg) ----- 33.0 (14.9) (+/- 5% TYPICAL)
- FULL WEIGHT (EXCLUDING INVENTORY) LBS(kg) ----- 68.0 (30.8) (+/- 5% TYPICAL)

**CANISTERS**

- (QUANTITY) SIZE ----- (6) 11"X3.2"OD (279mmX81mmOD)
- (1) 11"X3.2"OD (279mmX81mmOD)

**PLASTIC SHIPPING CONTAINER**

- PPSC----- PN 11912460

MDD 93/42/EEC CERTIFIED



Visit [www.mvebio.com](http://www.mvebio.com) for more information.

© 2021 MVE Biological Solutions reserves the right to discontinue its products, or change the prices, materials, equipment, quality, descriptions, specifications and/or processes to its products at any time without prior notice and with no further obligation or consequence. All rights not expressly stated herein are reserved by us, as applicable.

# MVE Vapor Shipper Series

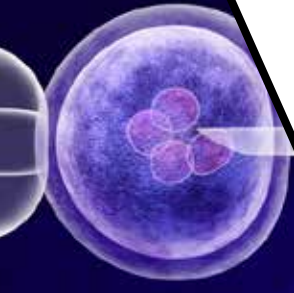

## Features include

- MVE Protective Shipping Containers are recommended
- Protective shipping containers ensure upright shipping
- Low liquid nitrogen consumption
- Convenient lightweight package
- CHARGES IN TWO HOURS\*

## Featuring Advanced QWick™ Charge Technology

The MVE Vapor Shipper Series is designed for the safe transportation of biological samples at cryogenic (-150°C or colder) temperatures. MVE Vapor Shipper Series utilizes the Advanced QWick Charge Technology that will charge the vapor shipper in two hours. \*New/warm tanks still need to be filled with LN<sub>2</sub> and allowed to sit for 24 hours to achieve maximum hold time. When a tank is already cold, the Advanced QWick Charge technology will apply, providing the benefit of same-day vapor shipping. Manufactured from durable, lightweight aluminum, the vapor shippers employ a hydrophobic compound which absorbs the liquid nitrogen to ensure dry, spill-free vapor-phase shipping.

MVE Protective Shipping Containers are recommended for usage. These containers may be used to ship your samples with a “non-hazardous” classification throughout the world, thus reducing costs and helping to assure sample viability.





## Tank Features



- A** Durable, tamper-proof lid design
- B** High strength neck tube reduces liquid nitrogen loss
- C** Strong, lightweight aluminum construction
- D** Advanced chemical vacuum retention system
- E** Hydrophobic Liquid Nitrogen absorbent system



	SC 2/1V	SC 4/2V	SC 4/3V	SC 20/12V	XC 20/3V**	XC 30/12V	Mini-Moover	Cryo-Moover	Cryo-Shipper	CryoShipper XC	IATA
<b>Maximum Storage Capacity</b>											
No. of Canisters	1	1	1	6	4 + 1 Canister		1	7	1 Rack	-	Stainless Steel Secondary Container
No. of 1/2 cc Straws 10/cane	-	280	120	540	2500/2000**		60	3080		-	
No. of 1/2 cc Straws 1 Level Bulk	88	44	210	780	3750/3000**	1 (6)	88	4354		-	
No. of 1/4 cc Straws 1 Level Bulk	182	938	452	1630	7410/6000	Tier Rack	185	-		-	
No. of 1.2 & 2.0 ml Vials 5/cane	-	95	40	150	675/560**		20	945		-	Dimensions:
No. of 1.2 & 2.0 ml Vials 6/cane	-	102	48	180	840/672**		24	1134	500	966 (Bulk)	7-3/8" diameter
No. of blood bags stored 4R9953	-	-	-	-	-		-	-	10	10	8-3/4" deep
<b>Performance (Hold Time overrides NER specifications)</b>											
LN <sub>2</sub> Capacity L est.	1.5	3.6	4.3	20.5	6.2	32.0	2.9	4.2	8.5	10.0	10.0
Static Holding Time Days	8	13	21	60	16	82	14	12	10	14	14
Static Evaporation Rate* L/day	0.19	0.26	0.20	0.09	0.35	0.22	0.20	0.35	0.85	0.70	0.70
<b>Unit Dimensions</b>											
Neck Opening in (mm)	1.40 (35.0)	2.75 (70.0)	2.00 (51.0)	2.18 (55.0)	3.81 (96.7)	2.50 (64)	1.40 (35.0)	3.80 (97.0)	8.50 (216.0)	8.50 (216.0)	8.50 (216.0)
Overall Height in (mm)	13.5 (343)	18.4 (468)	19.4 (492)	25.7 (652)	22.0 (559)	24.3 (617)	19.5 (495)	22.0 (558)	21.5 (546)	23.0 (584)	23.0 (584)
Outside Diameter in (mm)	7.25 (184)	8.70 (222)	8.70 (222)	14.50 (368)	14.50 (368)	17.0 (432)	7.25 (184)	18.30 (464)	14.50 (369)	15.00 (381)	15.00 (381)
Canister Height in (mm)	5.0 (127)	11.0 (279)	11.0 (279)	11.0 (279)	11.0 (279)	10.27 (260.85)	11.0 (279)	11.0 (279)	11.0 (279)	12.5 (317.5)	8.75 (222.25)
Canister Diameter in (mm)	1.20 (31)	2.62 (67)	1.81 (46)	1.50 (38)	3.20 (80)	1.73 (43.9) x 1.64 (41.7)***	1.20 (31)	3.10 (79)	5.6 (142) x 6.6 (167)***	8.5 (216)	7.375 (187.325)
Weight Empty lb. (kg)	6.0 (2.7)	10.0 (4.5)	11.6 (5.3)	28.4 (12.8)	25.1 (11.3)	44 (20)	9.0 (4.1)	30.5 (13.8)	26.1 (11.8)	33.0 (15.0)	33.0 (15.0)
Weight Charged vapor lb. (kg)	8.0 (3.6)	17.1 (7.7)	19.1 (8.7)	44.5 (20.1)	36.0 (16.3)	76 (34)	13.7 (6.2)	40.9 (18.6)	39.0 (17.7)	49.0 (22.2)	49.0 (22.2)
Weight Full liquid lb. (kg)	9.0 (4.1)	20.0 (9.1)	21.0 (9.5)	64.7 (29.3)	60.2 (27.3)	82 (37.2)	15.5 (7.0)	87 (39.5)	54.5 (24.7)	73.0 (33.1)	73.0 (33.1)
Protective Shipping Container Part No.	20750408	20750409	20750409	11912460	11912460	21325842	20750408	11930861	20750520	10741726	10741726

\* Without inventory

\*\* Optional center absorbent added to center canister (increases static hold time from 16 days to 18 days).

\*\*\* CryoShipper has a rectangular assembly measuring 5.6" (142 mm) by 6.6" (167 mm) with a usable height of 11.0" (279 mm).

Hold time specs actual performance may vary with atmospheric conditions, sample temperature, and usage.

**TWO Year Parts Warranty • THREE Year Vacuum Warranty**

Conforms to MDD 93/42/EEC, the Medical Device Directive for the EU.



Visit [www.mvebio.com](http://www.mvebio.com) for more information.

© 2021 MVE Biological Solutions reserves the right to discontinue its products, or change the prices, materials, equipment, quality, descriptions, specifications and/or processes to its products at any time without prior notice and with no further obligation or consequence. All rights not expressly stated herein are reserved by us, as applicable.



# MVE CryoCube™ & BL-7



Above:  
CryoCube insert

The MVE CryoCube and MVE BL-7 (Biologicistic) are secure cryogenic shipping options for your biological samples. Both units incorporate creative engineering and simplistic design to allow shipping in any orientation without sacrificing temperature or hold time. Improved welded construction provides the MVE CryoCube and MVE BL-7 with consistent, high quality design with every unit. **The units allow for savings on dry ice, packaging, shipping cost, and disposal.**

## Features include

- Charges in 2 hours
- Operates as a dry shipper
- -150° C temperature
- 7-day (BL-7) or 5-day (CryoCube) holding time
- Safe shipping in any orientation
- Safe for international shipping
- Welded construction for added integrity

	MVE CryoCube	MVE BL-7
<b>Maximum Storage Capacity</b>		
Number of Blood Bags	NA	NA
Number of Canisters	1	1
Number of 1/2 cc Straws 10/cane	88	115
Number of 1/2 cc Straws 1 Level Bulk	182	270
Number of 1.2 & 2.0 ml vials 5/cane	6	15
<b>Performance</b>		
LN <sub>2</sub> Capacity w/o Inventory L est.	1.5	2.1
Static Evaporation Rate* L/day	--	--
Static Holding Time* days	5	7
<b>Unit Dimensions</b>		
Neck Opening in. (mm)	1.4 (35)	1.97 (50)
Overall Height in. (mm)	12.5 (317.5)	15.0 (381)
Overall Width in. (mm)	12 (305)	12.64 (321)
Overall Diameter in. (mm)	1.25 (32)	1.50 (38)
Weight Empty lb. (kg)	7.5 (3.41)	9.26 (4.2)
Weight Charged vapor lb. (kg)	10.2 (4.63)	13.01 (5.9)
Warranty	TWO Year Vacuum Warranty	TWO Year Vacuum Warranty

\* Static evaporation rate and static holding time are nominal. Actual rate and holding time will be affected by the nature of container use, atmospheric conditions, and manufacturing tolerances.

Conforms to MDD 93/42/EEC, the Medical Device Directive for the EU.

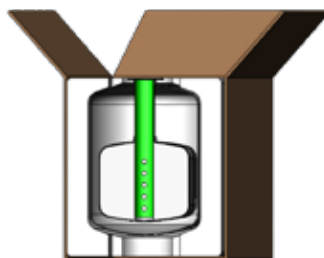

# MVE CryoShipper CT-50 & CT-250



	CT-50**	CT-250**
<b>Maximum Storage Capacity</b>		
Number of Blood Bags	2 (25 mL)	2 (250 mL)
<b>Performance</b>		
LN <sub>2</sub> Capacity w/o Inventory L est.	5	8
Static Evaporation Rate* L/day	0.5	0.8
Static Holding Time* days	10	10
<b>Unit Dimensions</b>		
Neck Opening in. (mm)	3.82 (97)	6.5 (165)
Overall Height in. (mm)	15 (380)	19.8 (502)
Outer Diameter/Width in. (mm)	14.5 (368)	16.0 (406)
Weight Empty lb. (kg)	17.6 (8)	24.3 (11)
Weight Charged vapor lb. (kg)	26.45 (12)	38.6 (17.5)
Warranty	TWO Year Vacuum Warranty	TWO Year Vacuum Warranty

\* Static evaporation rate and static holding time are nominal. Actual rate and holding time will be affected by the nature of container use, atmospheric conditions, and manufacturing tolerances.

\*\* CT = Cell Therapy

Conforms to MDD 93/42/EEC, the Medical Device Directive for the EU.

MVE's secure specialty shippers fill unique biological sample cryogenic shipping and storage needs. The MVE CryoShipper CT-50 and CT-250 are designed to ship specific blood bags sizes. Our unique rack designs hold one to two blood bags to help limit sample movement during transit. The new design can also store samples in liquid nitrogen after arrival at the destination.

## Features include

- Safe for international shipping; IATA Dangerous Goods Regulations Exempt (Special Provision A152)
- CryoShipper CT-50 and CT-250 charge in 2 hours

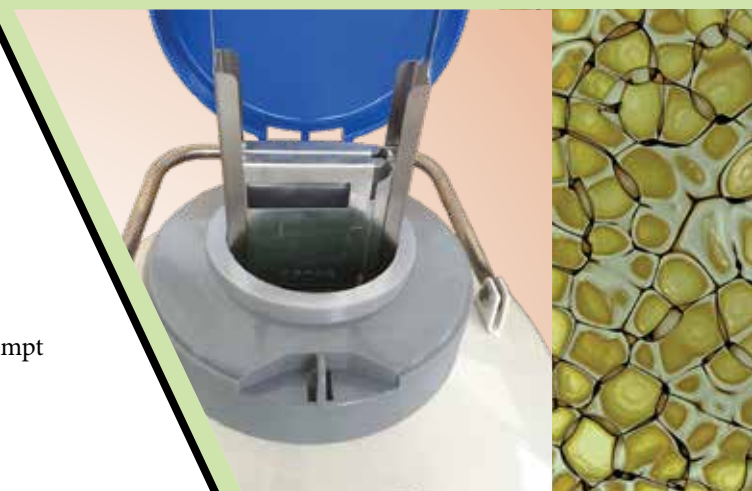

Visit [www.mvebio.com](http://www.mvebio.com) for more information.

© 2021 MVE Biological Solutions reserves the right to discontinue its products, or change the prices, materials, equipment, quality, descriptions, specifications and/or processes to its products at any time without prior notice and with no further obligation or consequence. All rights not expressly stated herein are reserved by us, as applicable.

# MVE CryoShipper 2000



The MVE CryoShipper 2000 is engineered specifically to ship large quantities of 1.2 and 2.0 mL vials. The new design can also store samples in liquid nitrogen after arrival at its destination.

## Features include

- Large capacity vapor shipments
- Low liquid nitrogen consumption
- -150°C or colder
- Protective shipping container available
- Datalogger accessory is available
- Charges in under 2 hours
- Safe for international shipping; IATA Dangerous Goods Regulations Exempt (Special Provision A152)



CryoShipper 2000	
<b>Maximum Storage Capacity</b>	
Number of Square Racks	4
Number of Boxes per Rack	5
Number of 1.2 & 2.0 mL vials (100/box)	2000
<b>Performance</b>	
LN <sub>2</sub> Capacity w/o Inventory L est.	65.0
Static Evaporation Rate* L/day	0.79
Static Holding Time* days	15
<b>Unit Dimensions</b>	
Neck Opening in. (mm)	8.5 (216)
Overall Height in. (mm)	27.2 (692)
Outer Diameter in. (mm)	22.0 (559)
Weight Empty lb. (kg)	65 (29.5)
Weight Charged vapor lb. (kg)	95 (43.1)
Weight Full lb. (kg)	185 (83.9)
Protective Shipping Container Part No.	12875162

\* Static evaporation rate and static holding time are nominal. Actual rate and holding time will be affected by the nature of container use, atmospheric conditions, and manufacturing tolerances.

**TWO Year Warranty • THREE Year Vacuum Warranty**

Conforms to MDD 93/42/EEC, the Medical Device Directive for the EU.

# PDF Logger®



With the PDF Logger®, you require only one single device and no specific software or cables to monitor temperature during the global transfer of cryobiological goods. After the datalogger has been in service for one year, simply discard the logger and purchase a new one for about the same cost of recalibration and battery replacement. Your PDF Logger is always under warranty!  
 Note that the PDF logger adds 0.11 L/day loss rate to any tank to which it is attached.

## Features include

- Records and stores up to 16,000 data points
- High and Low Alarm Settings
- No recalibrations
- 1 year lifespan\*
- No additional software or cables needed!
- ISO 19005-1
- Compliant: GMP, GLP

\* The battery in the PDF Logger only has a ONE YEAR life. To take advantage of the battery life, MVE will ship immediately to the customer once a new order is entered.

PDF Logger®	
<b>Specifications</b>	
Dimensions L, W, H in (mm)	3.7 x 1.6 x 0.5 (95 x 40 x 12)
Weight oz (g)	1.4 (40)
Temperature Range	-200°C to +200°C
Accuracy	± 0.5°C [-200°C, -10.1°C]
Resolution	0.1°C
Display	Multifunction LCD, 23.5 x 23.5 mm
Case	ABS plastic
Battery	3.6V
Battery Life	400 days
Sensor	Pt100 3-wire class 0.5
Memory	16,000 data points
Interface	USB – PC Universal Serial Bus
Evaluation Report	Built-in PDF file generator that automatically establishes an evaluation file including graph. Complies to the ISO Standard 19005-1 Document Management for the long-term preservation of electronic documents

**1 Year Warranty — No Returns**

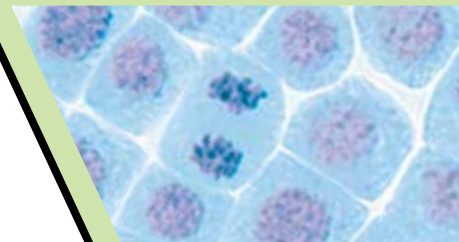

Visit [www.mvebio.com](http://www.mvebio.com) for more information.

© 2021 MVE Biological Solutions reserves the right to discontinue its products, or change the prices, materials, equipment, quality, descriptions, specifications and/or processes to its products at any time without prior notice and with no further obligation or consequence. All rights not expressly stated herein are reserved by us, as applicable.



# MVE 1536 Dry Shipper

The MVE 1536PD Dry Shipper is specifically designed to provide peace of mind when shipping and/or relocating samples.



## Features include

- Liquid Nitrogen absorbent can be charged for dry shipment
- Hold time up to 20 days when properly charged
- Rigid steel frame can be moved with pallet jack/forklift
- Sized to fit in a wide-body aircraft
- Inventory tray locks to prevent rotation during transit
- Locking lid
- Includes data logger to monitor and record sample temperature during shipment or relocation
- Inner vessel must be decontaminated after use.

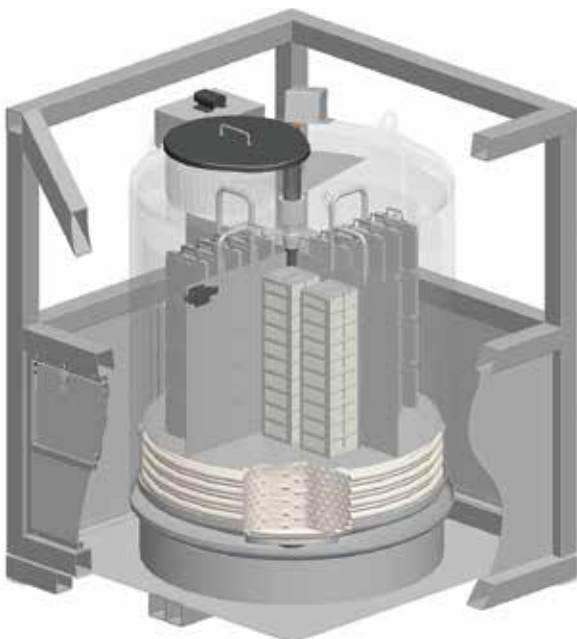



<b>MVE 1536PD</b>	
<b>Maximum Storage Capacity</b>	
1.2 & 2 ml Vials (Internally Threaded)	36400
Quantity of Large Racks 100 cell boxes	24
Quantity of Mini Racks 25 cell boxes	16
Number of Shelves per Rack	13
<b>Performance</b>	
Absorbed LN <sub>2</sub> Capacity L est.	320
<b>Unit Dimensions</b>	
Neck Opening in. (mm)	17.5 (444)
Usable Internal Height in. (mm)	30 (762)
Inner Diameter in. (mm)	38.5 (978)
Overall Height including Frame** in. (mm)	64 (1625)
Liftover Height in. (mm)	42.1 (1070)
Step Height in. (mm)	20.5 (521)
Depth of Fold Down Step in. (mm)	10.8 (274)
Footprint in. (mm)	52x52 (1321x1321)
Weight Empty* lb. (kg)	1600 (726)
Weight Liquid Full* lb. (kg) est.	2044 (927)

**TWO Year Parts Warranty • THREE Year Vacuum Warranty**  
 Conforms to MDD 93/42/EEC, the Medical Device Directive for the EU. Freezer systems UL/C-UL Listed.  
 \* Without inventory | \*\*Contact Tech Service for detailed drawings.

## Tank Features



Locking Cabinet



Data Logger



Top View



Tray

## TEMPERATURE TEST\*

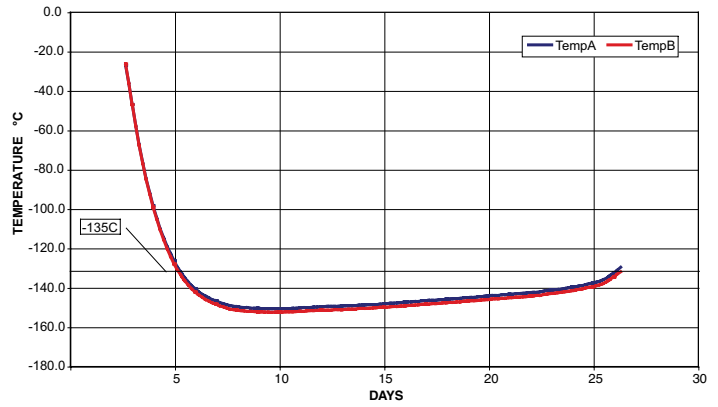

## Temperature Test Graph

\* Temp Test indicates typical performance of MVE 1536PD freezer with full inventory system and factory recommended level settings. Actual performance may vary with atmospheric conditions and usage.

## Rack Layout

### Square Rack Layout

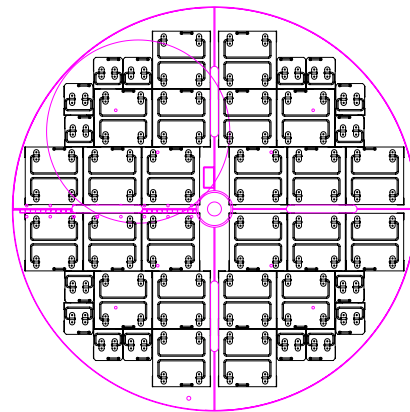

Visit [www.mvebio.com](http://www.mvebio.com) for more information.

© 2021 MVE Biological Solutions reserves the right to discontinue its products, or change the prices, materials, equipment, quality, descriptions, specifications and/or processes to its products at any time without prior notice and with no further obligation or consequence. All rights not expressly stated herein are reserved by us, as applicable.







# MVE's Cryogenic Solutions



## Dewars



## Freezers

**MVE Biological Solutions - Americas**  
+1-844-683-2796  
customerservice.usa@mvebio.com  
breeders.cs@mvebio.com

**MVE Tech Service**  
techservice@mvebio.com

**MVE Biological Solutions - EMEA**  
+44 7718 488236  
customerservice.europe@mvebio.com  
breeders.europe@mvebio.com

**MVE Biological Solutions - Asia**  
Customer Services: +86 28 6572 9660  
Jessy Yang - Direct: +86 28 6572 9668  
China: customerservice.china@mvebio.com  
Asia: csasia@mvebio.com



Visit [www.mvebio.com](http://www.mvebio.com) for more information.

Copyright © 2021 MVE Biological Solutions reserves the right to discontinue its products, or change the prices, materials, equipment, quality, descriptions, specifications and/or processes to its products at any time without prior notice and with no further obligation or consequence. All rights not expressly stated herein are reserved by us, as applicable.

©2021 MVE ML CRYO 0009 P