



LABCONCO CORPORATION
8811 Prospect Avenue
Kansas City, MO 64132
(800) 821-5525, (816) 333-8811
(816) 363-0130 fax
labconco@labconco.com

User's Manual

FreeZone[®] Stoppering Tray Dryers

Models

794801*** Series

To receive important product updates,
complete your product registration card
online at register.labconco.com

Please read the User's Manual before operating the equipment.

Copyright © 2018 Labconco Corporation. The information contained in this manual and the accompanying products are copyrighted and all rights reserved by Labconco Corporation. Labconco Corporation reserves the right to make periodic design changes without obligation to notify any person or entity of such change.

Warranty

Labconco Corporation provides a warranty to the original buyer for the repair or replacement of parts and reasonable labor as a result of normal and proper use of the equipment with compatible chemicals. Broken glassware and maintenance items, such as filters, gaskets, light bulbs, finishes and lubrication are not warranted. Excluded from warranty are products with improper installation, erratic electrical or utility supply, unauthorized repair and products used with incompatible chemicals.

The warranty for FreeZone® Stoppering Tray Dryers will expire one year from date of installation or two years from date of shipment from Labconco, whichever is sooner. Warranty is non-transferable and only applies to the owner (organization) of record.

Buyer is exclusively responsible for the set-up, installation, verification, decontamination or calibration of equipment. This limited warranty covers parts and labor, but not transportation and insurance charges. If the failure is determined to be covered under this warranty, the dealer or Labconco Corporation will authorize repair or replacement of all defective parts to restore the unit to operation. Repairs may be completed by 3rd party service agents approved by Labconco Corporation. Labconco Corporation reserves the rights to limit this warranty based on a service agent's travel, working hours, the site's entry restrictions and unobstructed access to serviceable components of the product.

Under no circumstances shall Labconco Corporation be liable for indirect, consequential, or special damages of any kind. This warranty is exclusive and in lieu of all other warranties whether oral, or implied.

Returned or Damaged Goods

Do not return goods without the prior authorization from Labconco. Unauthorized returns will not be accepted. If your shipment was damaged in transit, you must file a claim directly with the freight carrier. Labconco Corporation and its dealers are not responsible for shipping damages.

The United States Interstate Commerce Commission rules require that claims be filed with the delivery carrier within fifteen (15) days of delivery.

Limitation of Liability

The disposal and/or emission of substances used in connection with this equipment may be governed by various federal, state, or local regulations. All users of this equipment are required to become familiar with any regulations that apply in the user's area concerning the dumping of waste materials in or upon water, land, or air and to comply with such regulations. Labconco Corporation is held harmless with respect to user's compliance with such regulations.

Contacting Labconco Corporation

If you have questions that are not addressed in this manual, or if you need technical assistance, contact Labconco's Customer Service Department or Labconco's Product Service Department at 1-800-821-5525 or 1-816-333-8811, between the hours of 7:30 a.m. and 5:30 p.m., Central Standard Time.

TABLE OF CONTENTS

CHAPTER 1: INTRODUCTION	1
Intended Use	1
Freeze Dry Process	1
Freeze Dry Rates	2
Freeze Dry Capacity	3
Samples Containing Volatile Substances	4
About This Manual	4
Typographical Conventions	5
CHAPTER 2: PREREQUISITES	6
Electrical Requirements	6
Location Requirements	7
Vacuum Pump Requirements	7
CHAPTER 3: GETTING STARTED	8
Unpacking Your Stoppering Tray Dryer	8
Stoppering Tray Dryer Components	9
Setting Up Your Stoppering Tray Dryer	9
Installing Stoppering Tray Dryer on a Console Freeze Dryer	9
Electrical Connection	10
Communication Cable	11
Ground Strap	11
Sample Probes	11
Testing System Vacuum Integrity	11
Venting the Vacuum Pump	12
Chemical Resistance of Freeze Dryer Components	12
Solvent Safety Precautions	13
CHAPTER 4: USING YOUR STOPPERING TRAY DRYER	14
Component Identification	15
Operation Checklist	16
Operating the Stoppering Tray Dryer	17
Drying Accessory Screen	17
Manual Mode	18
Starting Manual Mode	19
Changing Shelf Temp Set Point Value	19
Stopping Manual Mode	20

Programs	20
Creating a New Program	22
Starting a Program	23
Stopping a Program	23
Freeze Drying Using the Manifold Valves	24
Shelf Spacing Adjustment	26
Shelf Loading	27
Sample Freezing	27
Freeze Drying	28
Stoppering	28
Vacuum Break/Backfilling	28
Alerts	29
Power Fail	29
Line Voltage Range	29
System Temp Variation	29
Vacuum Variation	29
System Temp Set Point	30
Program Complete	30
CHAPTER 5: MAINTAINING YOUR STOPPERING TRAY DRYER	31
Service Safety Precautions	31
Routine Maintenance Schedule	31
CHAPTER 6: TROUBLESHOOTING	33
Vacuum Pump	33
Gaskets, Tubing, Connections, Sample Valves	34
System Components & Collector Chamber Isolation	35
Stoppering Tray Dryer	37
Door Adjustment	37
Refrigeration Module Operation	38
Access to Mechanical Components	38
Shelf and Stoppering System Removal	39
Filling the Fluid System	40
Heat Transfer Fluid Precautions	41
Heat Transfer Fluid First Aid Procedures	42
APPENDIX A: COMPONENTS	43
APPENDIX B: DIMENSIONS	45
APPENDIX C: SPECIFICATIONS	47
Electrical Specifications	47
Environmental Conditions	47
APPENDIX D: ACCESSORIES	48

CHAPTER 1

INTRODUCTION

Congratulations on your purchase of a Labconco FreeZone® Freeze Dry System, which is designed for laboratory lyophilization procedures. The refrigerant used in the refrigeration system is HCFC-free so it will not endanger the environment. The unit is easy to install and maintain. Proper care and maintenance of this product will result in many years of dependable service.

Intended Use

The Stoppering Tray Dryer is intended to be used in conjunction with Labconco Console Freeze Dryers in a laboratory setting to facilitate the lyophilization process.

Freeze Dry Process

Freeze drying is an important process in sample preparation and for the preservation and storage of biologicals, pharmaceuticals and foods. Of the various methods of dehydration, freeze drying (lyophilization) is especially suited for substances that are heat sensitive. Other than food processing (e.g., coffee, whole dinners), freeze drying has been extensively used in the development of pharmaceuticals (e.g., antibiotics) and preservation of biologicals (e.g., proteins, plasma, viruses and cell lines). The nondestructive nature of this process has been demonstrated by the retention of viability in freeze dried viruses and microorganisms.

Freeze drying is a process whereby water or other solvent is removed from frozen material by converting the frozen water directly into vapor without the intermediate formation of liquid water. The basis for this sublimation process involves the absorption of heat by the frozen sample in order to vaporize the ice; the use of a vacuum pump to enhance the removal of water vapor from the surface of the sample; the transfer of water vapor to a collector; and the removal of heat by the collector in order to condense the water vapor. In essence, the freeze dry process is a balance between the heat absorbed by the sample to vaporize the ice and the heat removed from the collector to convert the water vapor into ice.

Freeze Dry Rates

The efficiency of the Freeze Drying process is dependent upon the surface area and the thickness of the sample, the collector temperature and vacuum obtained, the eutectic point and solute concentration of the sample. It is important to remember these factors when trying to obtain efficient utilization of your Freeze Dry system. A listing of selected materials and their approximate drying times are shown in Table 1 for your reference.

Table 1

SAFE TEMPERATURE AND DRYING TIMES FOR SELECTED MATERIALS			
Material 10mm Thick	Safe Temperature °C	Collector Temperature °C	Hours (Approx.)
Milk	-5	-40	10
Urea	-7	-40	10
Blood Plasma	-10 to -25	-40	16
Serum	-25	-40	18
Vaccinia	-30 to -40	-50	22
Influenza Vaccine	-30	-50	24
Human Tissue	-30 to -40	-50	48
Vegetable Tissue	-50	-80	60

*Total sample quantities are contingent on various freeze dryer capacities.

Up to the point of overloading the system, the greater the surface area of the sample, the faster the rate of freeze drying. By contrast, for a given surface area, the thicker the sample the slower the rate of freeze drying. This is based on the fact that the heat of sublimation is usually absorbed on one side of the frozen sample and must travel through the frozen layer to vaporize water at the other surface. In addition, as the sample is freeze dried, the water vapor must travel through the layer of dried material. The thicker the sample, the greater the chance that the dried layer may collapse which would cause an additional decrease in the rate of freeze drying.

The surface area and thickness of the sample can usually be ignored when each sample contains only a few milliliters. However, for larger volumes, the samples should be shell frozen to maximize the surface area and minimize the thickness of the sample. The volume of the freeze dry flask should be two to three times the volume of the sample.

In order for lyophilization to occur, ice must be removed from the frozen sample via sublimation. This is accomplished by the collector and the vacuum pump. The collector, which should be at least 15 to 20°C colder than the eutectic temperature (melting temperature) of the sample, traps vapor as ice. Since the vapor pressure at the collector is lower than that of the sample, the flow of water vapor is from the sample to the collector. Since this vapor diffusion process occurs very slowly under normal atmospheric conditions, a good vacuum is

essential to maintain an efficient rate. In many applications, the maintenance of a vacuum of 0.133 mbar or less is recommended.

The rate of freeze drying is directly proportional to the vapor pressure and the vapor pressure is dependent upon both eutectic temperature and solute concentration of the sample. For example, a solution of sodium chloride and water would freeze dry at a slower rate than pure water. The eutectic temperature of a sodium chloride solution is about -21°C and at this temperature the vapor pressure is about 1/16 that of water at 0°C . Although the eutectic temperature is not dependent upon the concentration of sodium chloride, the vapor pressure of the water would decrease as the concentration of sodium chloride increased. This is due to the fact that as the solute concentration increases, less of the surface area of the frozen sample is occupied by water. In general, most solutions or biological samples will have a eutectic temperature of -10 to -25°C . However, if the sample contains a simple sugar such as glucose or if the sample is animal or plant tissue, the eutectic temperature may be as low as -30° to -50°C .

Freeze Dry Capacity

The volume of a sample that can be freeze dried at one time is related to factors discussed previously and the size and design of the freeze dry system. With any given instrument, the capacity is based on the surface area of the sample; the eutectic temperature and concentration of the sample; and the rate and amount of heat transferred to the frozen sample. Of these factors, the eutectic temperature is the most important factor in determining the amount of sample that can be freeze dried at one time, particularly when flasks are used. This is because as the eutectic temperature decreases, the vapor pressure decreases but the rate of heat absorption by the sample does not change. This tends to promote melting of the sample, which leads to a marked increase in vapor pressure and ultimately overloads the collector and vacuum pump. Samples that have eutectic temperatures of -20°C or lower should be placed on the freeze dry system one flask at a time so that the vacuum in the system may recover before adding another sample to the system. If the vacuum does not recover, the capacity of the freeze dry system has been exceeded and the sample should be removed.

If there is a problem with a particular type of sample melting when placed on the freeze dry system, dilution of the sample with more water or providing some insulation around the flask to decrease the rate of heat absorption by the sample may help. If the eutectic temperature of the sample is -40 to -60°C , the freeze dry system selected for use must be equipped with cascade type refrigeration so that the collector temperature can be cooled to below -75°C , or a dry ice/solvent trap may be used between the collector and the vacuum pump.

Samples Containing Volatile Substances

In certain cases the solvent in a sample to be freeze dried may contain volatile components such as acetonitrile, methanol, acetic acid, formic acid or pyridine. In addition to these substances having an effect on the eutectic temperature, they may increase the vapor pressure at the surface of the sample. Also, compared to water, they will require the absorption of less heat for sublimation to occur. Hence, samples that contain volatile substances will have a greater tendency to melt, particularly when placed in flasks or exposed to room temperature. If a sample containing a volatile substance tends to melt when placed on a freeze dry system, dilution of the sample with more water will help keep the sample frozen. For example, a 0.2M solution of acetic acid is much easier to freeze dry than a 0.5M solution.

About This Manual

This manual is designed to help you learn how to install, use, and maintain your Stoppering Tray Dryer. Instructions for performing routine maintenance and making minor modifications to your Stoppering Tray Dryer are also included.

Chapter 1: Introduction provides a brief overview of the freeze dry process, explains the organization of the manual, and defines the typographical conventions used in the manual.

Chapter 2: Prerequisites explains what you need to do to prepare your site before you install your Stoppering Tray Dryer. Electrical requirements are discussed.

Chapter 3: Getting Started contains the information you need to properly unpack, inspect and install your Stoppering Tray Dryer.

Chapter 4: Using Your Stoppering Tray Dryer discusses the basic operation of your Stoppering Tray Dryer. Information on how to load samples and run the Stoppering Tray Dryer is included.

Chapter 5: Maintaining Your Stoppering Tray Dryer explains how to perform routine maintenance on your Stoppering Tray Dryer.

Chapter 6: Using the RS-232 Receptacle describes how to connect a computer for monitoring the operation.

Chapter 7: Troubleshooting contains information about problems you may encounter while using your Stoppering Tray Dryer, including the probable causes of the problems, and suggested corrective actions.

Chapter 8: Modifying Your Stoppering Tray Dryer Display describes how to calibrate the vacuum display and restore factory settings.

Appendix A: Components contains labeled diagrams of the components of the Stoppering Tray Dryer.

Appendix B: Dimensions contains comprehensive diagrams showing the dimensions for the Stoppering Tray Dryer.

Appendix C: Specifications contains product specifications.

Appendix D: Accessories see www.labconco.com for a complete list of Stoppering Tray Dryer accessories.

Typographical Conventions

Recognizing the following typographical conventions will help you understand and use this manual:

- Book, chapter, and section titles are shown in italic type (e.g., *Chapter 3: Getting Started*).
- Steps required to perform a task are presented in a numbered format.
- Comments located in the margins provide suggestions, reminders, and references.
- Critical information is presented in boldface type in paragraphs that are preceded by the exclamation icon. Failure to comply with the information following an exclamation icon may result in injury to the user or permanent damage to your Freeze Dryer.
- Important information is presented in capitalized type in paragraphs that are preceded by the pointer icon. It is imperative that the information contained in these paragraphs be thoroughly read and understood by the user.



CHAPTER 2

PREREQUISITES

Before you install your Stoppering Tray Dryer, you need to prepare your site for installation. The Stoppering Tray Dryer will mount on top of a FreeZone 6, 12 or 18 liter Console Freeze Dryer. Carefully examine the location where you intend to install your Stoppering Tray Dryer. You must be certain that the area is level and of solid construction. An electrical source must be located near the installation site.

Carefully read this chapter to learn:

- Electrical supply requirements.
- Vacuum pump requirements.

Refer to *Appendix C: Specifications* for complete Stoppering Tray Dryer electrical and environmental conditions, specifications and requirements.

Refer to the User's Manual for the FreeZone Console Freeze Dryers for complete electrical and environmental conditions, specifications and requirements.

Electrical Requirements

- 115V models
 - 20 Amp dedicated single phase circuit.
 - Properly grounded receptacle for NEMA 5-20P plug.
- 230V models
 - 15 Amp dedicated single phase circuit.
 - Properly grounded receptacle that matches the plug supplied with the unit, (230V models are supplied with one of the following plugs):



US
NEMA 5-20P

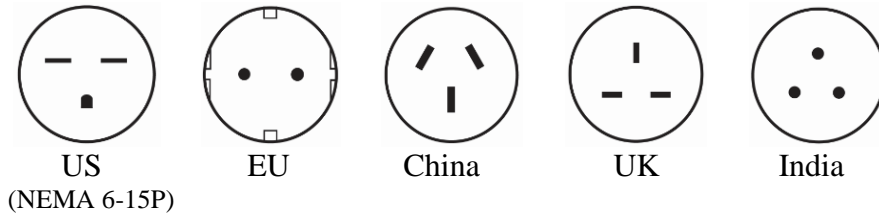

- If the plug does not match the available receptacle, remove the plug and replace it with an approved plug of the suitable style.



Do not use any detachable power cord that is not adequately rated for the unit.



**Frequency must agree with the serial tag rating.
Improper frequency will damage the compressor.**

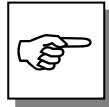

ADDITIONAL APPLIANCES ON THE SAME CIRCUIT MAY CAUSE THE CURRENT TO EXCEED THE RATING OF THE CIRCUIT BREAKER OR FUSE.

Location Requirements

The Freeze Dryer should be located in an area that provides an unobstructed flow of air around the cabinet. This air cools the refrigeration system. The refrigeration system draws air in through the front and exhausts it through the rear. A minimum of 3" must be allowed between the rear and both sides of the Freeze Dryer and adjacent wall surfaces. Restriction of airflow during operation could adversely affect performance. Refer to *Appendix B: Dimensions* for dimensional drawings of the Stoppering Tray Dryer.

Vacuum Pump Requirements

A vacuum pump must be provided by the user. A vacuum pump with a displacement of 163 liters per minute and 0.007 mbar ultimate pressure is adequate for most samples. The inlet fitting on the vacuum pump must be suitable for 3/4" ID vacuum hose, which is provided. It is recommended that the vacuum pump is equipped with an exhaust filter to minimize oil mist exhausting from the vacuum pump. The operating vacuum level may be set on the Freeze Dryer. The higher the vacuum set point, the more likely it is that oil mist will be exhausted.

Vacuum pumps used with 115V models should be equipped with a 115V, 15 Amp NEMA 5-15P plug. Vacuum pumps used with 230V models should be equipped with a reverse IEC plug (included with 230V pumps purchased from Labconco). This will allow the vacuum pump to be plugged into the receptacle on the rear electrical panel of the Console Freeze Fryer.

CHAPTER 3

GETTING STARTED

Now that the site for your Stoppering Tray Dryer is properly prepared, you are ready to unpack, inspect, install and test your Stoppering Tray Dryer. Read this chapter to learn how to:

- Unpack and move your Stoppering Tray Dryer.
- Set up your Stoppering Tray Dryer.
- Connect the electrical supply source to your Stoppering Tray Dryer.
- Safely use solvents with your Stoppering Tray Dryer.



The Stoppering Tray Dryer weighs over 400 lbs. (181 Kg). The carton allows for lifting with a mechanical lift truck or hand truck. If you must lift the Stoppering Tray Dryer manually, use at least four (4) persons and follow safe lifting guidelines.

Unpacking Your Stoppering Tray Dryer

Carefully unpack your Stoppering Tray Dryer and inspect it for damage that may have occurred in transit. If your Stoppering Tray Dryer is damaged, notify the delivery carrier immediately and retain the entire shipment intact for inspection by the carrier.

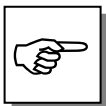

DO NOT RETURN GOODS WITHOUT THE PRIOR AUTHORIZATION OF LABCONCO. UNAUTHORIZED RETURNS WILL NOT BE ACCEPTED.

The United States Interstate Commerce Commission rules require that claims be filed with the delivery carrier within fifteen (15) days of delivery.

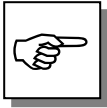

IF YOUR STOPPERING TRAY DRYER WAS DAMAGED IN TRANSIT, YOU MUST FILE A CLAIM DIRECTLY WITH THE FREIGHT CARRIER. LABCONCO CORPORATION AND ITS DEALERS ARE NOT RESPONSIBLE FOR SHIPPING DAMAGE.

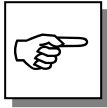

DO NOT DISCARD THE CARTON OR PACKING MATERIAL FOR YOUR STOPPERING TRAY DRYER UNTIL YOU HAVE CHECKED ALL OF THE COMPONENTS AND INSTALLED AND TESTED THE STOPPERING TRAY DRYER.

Stoppering Tray Dryer Components

Verify that the components listed below are present and undamaged.

Qty	Part #	Description	Comments
1	794801***	Stoppering Tray Dryer	
1	1089005	User's Manual	<i>USB Flash Drive</i>
1		Power Cord	<i>See parts list (Appendix A)</i>
1	7364601	Communication Cable	
3	7365800	Sample Temp Sensor	
8	1911416	Washer, 1/4"	
4	1905621	Nut, 1/4 - 20	
4	1880712	Screw, 1/4 - 20 x .75 long	

If you did not receive one or more of the components listed for your Stoppering Tray Dryer, or if any of the components are damaged, contact Labconco Corporation immediately for further instructions.

Setting Up Your Stoppering Tray Dryer

After you verify receipt of the proper components, move your Stoppering Tray Dryer to the location where you want to install it. Then, follow the steps listed below.

Installing the Stoppering Tray Dryer on a Console Freeze Dryer

The following tools are required to install the Stoppering Tray Dryer onto a FreeZone Console Freeze Dry: Flat blade screwdriver or 5/16" socket, and a 7/16" wrench or socket.

1. Remove the four plastic hole plugs from the top of the Freeze Dryer on which the Stoppering Tray Dryer is to be mounted.
2. If the Freeze Dryer has a flat gasket around the 3.0 inch vacuum port, remove it.

Chapter 3: Getting Started

- Loosen both clamps on the lower rubber coupling and slide the coupling upward so the bottom edge of the coupling is above the lower edge of the stainless steel tube. Snug both clamps on the coupling to hold them in place.

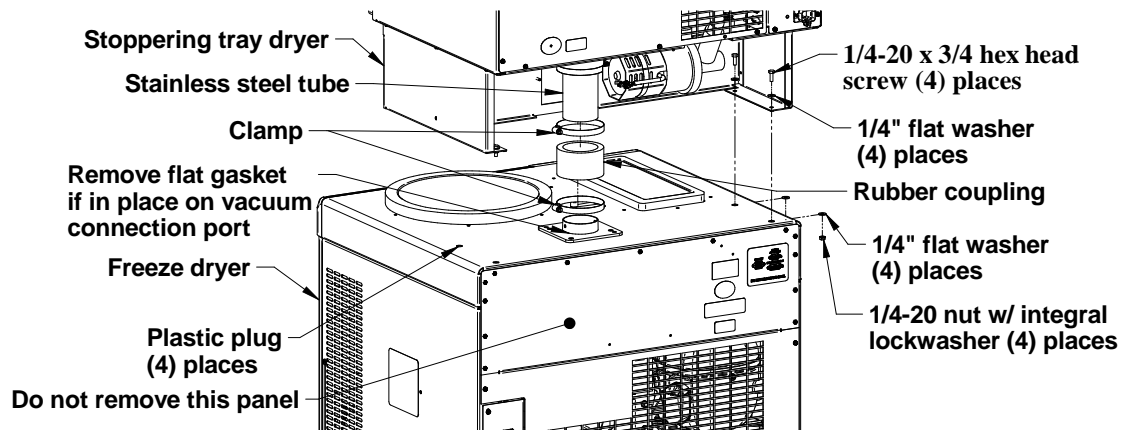

- Lift the Stoppering Tray Dryer into place on your Freeze Dryer while centering the vacuum coupling over the vacuum connection port. Align the four mounting holes in the Stoppering Tray Dryer support stand with the four holes in the top of the Freeze Dryer. Install the four bolts, nuts, and washers provided.

NOTE: Do not lift the Stoppering Tray Dryer by the acrylic door.

- Loosen the clamps and slide the lower rubber coupling down over the vacuum connection port. Orient the clamps to gain access and tighten the clamps to provide a leak-free connection.

Electrical Connection

Plug the power cord into the receptacle on the back of the Stoppering Tray Dryer and plug the other end into a suitable power receptacle.

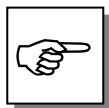

DO NOT ATTEMPT TO PLUG THE STOPPERING TRAY DRYER INTO THE FREEZONE FREEZE DRYER.



CAUTION: When the appropriate power cord is plugged into the power receptacle on the rear panel of the Stoppering Tray Dryer, the clamp on the receptacle should be tightened to prevent the cord from accidentally being switched with the Freeze Dryer cord located underneath the Tray Dryer. (The Freeze Dryer may require different mains A.C. voltage and switching these power cords may cause damage).

Communication Cable

The Freeze Dryer power cord should be unplugged before connecting the communication cable. Connect one end of the communication cable (7364601) to the port on the back of the Stoppering Tray Dryer labeled “OUTPUT TO FREEZE DRYER”. Connect the other end to the port on the back of the Freeze Dryer labeled “DRYING ACCESSORY”. Plug the Freeze Dryer power cord back into a suitable power receptacle.

Ground Strap

Connect the Ground Strap by removing one of the screws from the Freeze Dryer back panel and attaching the free end of the Ground Strap.

Sample Probes

If desired, connect the sample probes into the receptacles inside the chamber.

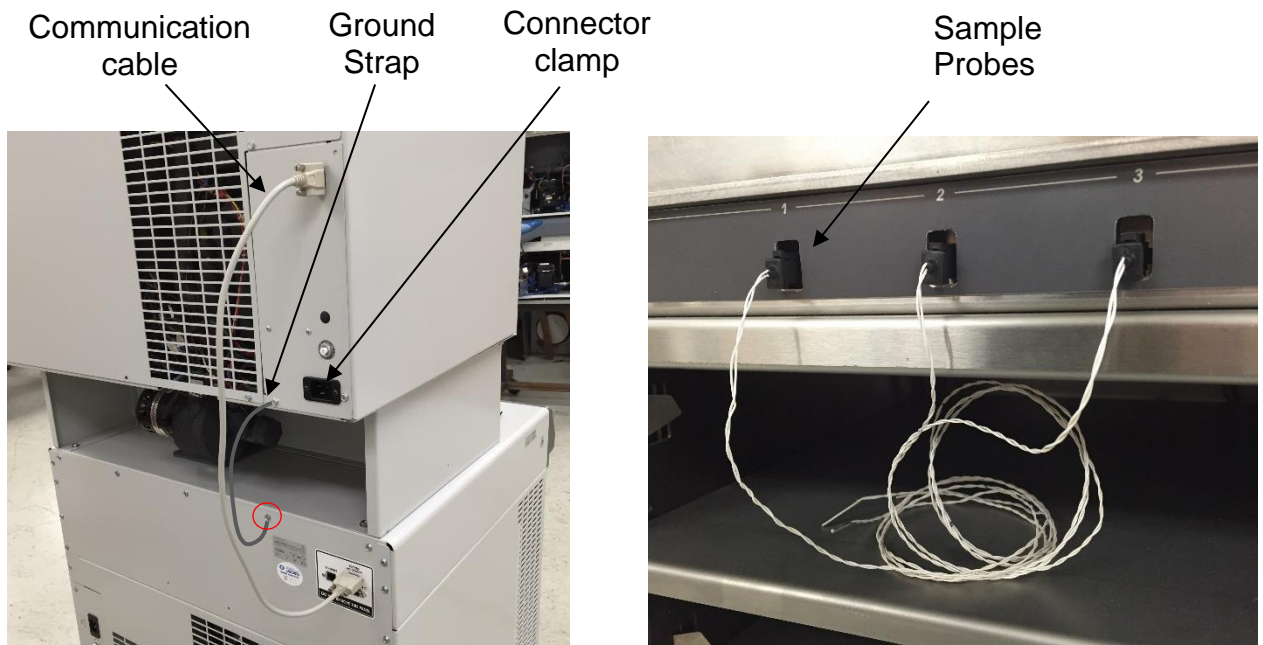

Testing System Vacuum Integrity

The Stoppering Tray Dryer is now installed and must be tested to make certain the system is free of leaks. To test, turn on the Freeze Dryer refrigeration (COLLECTOR) and allow the temperature to reach -40° or lower. Close the door of the Tray Dryer and make sure the Stoppering control is in the “LOWER” position and the Vac Release valve is in the “CLOSE” position. Start the vacuum pump and monitor the vacuum reading on the Freeze Dryer display. The vacuum should reach 0.133 mbar within 30 minutes and should achieve an ultimate vacuum of 0.040 mbar or lower within 18 hours. If 0.040 mbar cannot be achieved, consult the troubleshooting section of this manual and of the manual supplied with the Freeze Dryer.

Chapter 3: Getting Started

Venting the Vacuum Pump



If any materials will be placed in the Stoppering Tray Dryer that can liberate hazardous gases when heated, the vacuum pump exhaust must be vented to a fume hood or other ventilation device.

Chemical Resistance of Freeze Dryer Components

The FreeZone Freeze Dryer and Stoppering Tray Dryer are designed to be chemically resistant to most compounds that are commonly used in freeze drying processes. However, by necessity, the Freeze Dryer is comprised of a number of different materials, some of which may be attacked and degraded by certain chemicals. The degree of degradation is dependent on the concentration and exposure duration. Some of the major components of the FreeZone Freeze Dry System that are susceptible to degradation are as follows:

Component	Material	Acids			Buffers		Solvents						
		Acetic Acid 20%	Formic Acid	Trifluoroacetic Acid (TFA)	Calcium Chloride	Sodium Phosphate	Acetone	Acetonitrile	Carbon Tetrachloride	Cyclohexane	Dioxane	Methyl t-Butyl Ether (BTBE)	Pyridine
Valve Stem	Acetal	C	D	D	D		D						
Collector* Lid & Door	Acrylic			D			D	D	D				
Hoses, Gaskets & Valve Bodies	Neoprene	C	D	D			C	C	D	D	D	C	D
Flask Top	Silicon Rubber		C	D		D			D	D	D	C	D
Chamber & Fittings	Stainless Steel				C								

* An accessory glass lid is available for the Freeze Dry Systems.

C – Moderate degradation; Limited use.

D – Severe degradation; infrequent use recommended; immediate thorough cleaning required.

- Most common compounds used in freeze drying processes, if allowed to enter the vacuum pump, will degrade the oil and cause damage to the vacuum pump.

- Sugars and proteins typically will have minimal negative effect on any of the materials of construction.

When using compounds in the Freeze Dryer that are hostile to the materials of construction, it is imperative the equipment is thoroughly cleaned after use.

- Rubber and plastic components that have been exposed to damaging compounds should be removed and flushed with water.
- The oil in the vacuum pump should be checked often. It must be changed if it is cloudy, shows particles or is discolored. The useful life of vacuum pump oil can be extended if the vacuum pump is operated for an extended period of time after a freeze dry run. This allows contaminants to be purged from the hot oil. This must be done with the inlet to the pump blocked off to prevent air from free flowing through the pump. This is accomplished by closing all sample valves on a clean, dry freeze dry system and turning on the vacuum pump. If the pump is operated at an elevated vacuum level ($> 10\text{mbar}$), oil may be expelled from the pump and damage could occur.

Another way to extend the life of the vacuum pump is to install an optional secondary trap in the line between the Freeze Dry System and the vacuum pump. Contact Labconco for ordering information.

With prudent maintenance the FreeZone Freeze Dry System will provide years of service. Warranty on the affected parts will be voided if maintenance has been obviously neglected. If you have questions about using specific compounds in the Freeze Dry System, contact Labconco Technical Service at 1-800-821-5525 or 816-333-8811 or e-mail: labconco@labconco.com.

Solvent Safety Precautions



Solvents used in the Stoppering Tray Dryer may be flammable or hazardous to your health. Use extreme caution and keep sources of ignition away from the solvents. When using flammable or hazardous solvents, the vacuum pump must be vented to a fume hood.

Hazardous materials such as strong acids or bases, radioactive substances and volatile organics must be handled carefully and promptly cleaned up if spilled. If a sample is spilled in the collector chamber it must immediately be cleaned up.

WARNING: The disposal of substances used in connection with this equipment may be governed by various Federal, State or local regulations. All users of this equipment are urged to become familiar with any regulations that apply in the user's area concerning the dumping of waste materials in or upon water, land or air and to comply with such regulations.

CHAPTER 4

USING YOUR STOPPERING TRAY DRYER

After your Stoppering Tray Dryer has been installed as detailed in *Chapter 3: Getting Started*, you are ready to begin using your Stoppering Tray Dryer. Read this chapter to learn how to:

- Operate the controls.
- Understand the display.
- Connect samples.



Do not use the Stoppering Tray Dryer in a manner not specified by the manufacturer (refer to *Appendix C: Specifications*). The electrical protection properties of the Stoppering Tray Dryer may be impaired if the Stoppering Tray Dryer is used inappropriately.

Component Identification

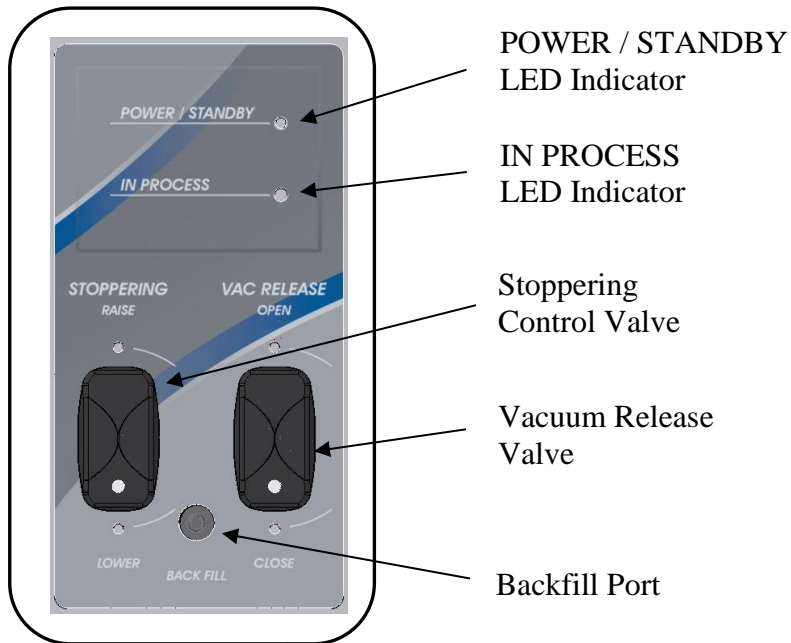

Chapter 4: Using Your Stoppering Tray Dryer

Power Switch – Turns all AC power to the Tray Dryer ON or OFF.

POWER / STANDBY LED Indicator – Indicates if the power switch is ON or OFF.

IN PROCESS LED Indicator – This light will be ON if the Stoppering Tray Dryer is running in either MANUAL or PROGRAM mode.

Stoppering Control Valve – Controls the operation of the stoppering bladder. The white dot on the valve knob indicates the position of the valve. Turning the valve to the RAISE position will inflate the bladder to perform the stoppering operation. Turning the valve to the LOWER position will cause the bladder to deflate.

Vacuum Release Valve - Vents the chamber to allow the chamber door to be opened.

Backfill Port – A regulated gas cylinder may be connected to this port to allow the introduction of a desired gas into the chamber after freeze drying. The port accepts 1/8" ID tubing.



Ethylene Oxide is not recommended for use in this Tray Dryer for decontamination because of its hazardous and corrosive properties.

Sample Probe Ports – (3) sample probes may be plugged into the Stoppering Tray Dryer to monitor the sample temperature during the freeze drying process.

Stoppering Bladder – Can be inflated to perform vial stoppering

Operation Checklist

The following checklist should be followed prior to each use of your Stoppering Tray Dryer:

1. Using a soft, lint-free cloth, wipe the Stoppering Tray Dryer chamber to remove any moisture or debris. Wipe door gasket to remove any debris or other contaminants that could cause a vacuum leak. Vacuum grease is NOT required on the door gasket to obtain a proper vacuum seal.
2. Remove the collector chamber lid from the Freeze Dryer and ensure that the collector chamber and drain line are free of water. Place the drain hose in a suitable container to collect the condensate from the collector chamber and insert the quick connect drain fitting into the quick connect drain coupling located on the left hand side of the Freeze Dryer. **Freeze Dryer (Collector or Vacuum) will not start if moisture is detected in the drain line.**
3. After completely draining the system, disconnect the quick connect drain fitting from the quick connect drain coupling.

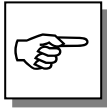

DISCONNECT THE QUICK CONNECT DRAIN FITTING BEFORE STARTING THE VACUUM PUMP. FAILURE TO REMOVE THE FITTING WILL RESULT IN A LARGE VACUUM LEAK.

4. Wipe the interior of the collector chamber and baffle (if equipped) with a soft cloth or paper towel to remove any remaining moisture.
5. Using a soft lint-free cloth wipe the collector chamber lid gasket to remove any debris or contaminants that could cause a vacuum leak, then install the lid on the collector chamber. Vacuum grease is NOT required on the collector chamber lid gasket to obtain a proper vacuum seal.
6. If the optional 6-Port manifold accessory is installed on your Stoppering Tray Dryer, make sure that each sample valve is in either the “closed” or “vent” position.
7. Start the Freeze Dryer COLLECTOR and allow the refrigeration system to reach its specified operating temperature (-50°C, -84°C depending on model).
8. Load samples onto Stoppering Tray Dryer shelves and latch chamber door.



The stoppering mechanism is capable of generating a very strong force, which can damage the shelves or mechanism. Therefore, it is important to distribute the serum bottles to be stoppered evenly across the entire surface of each shelf.

9. If samples were pre-frozen, Start VACUUM. If the shelves will be used to freeze the samples, do not start the vacuum until the samples are fully frozen.
10. Start Stoppering Tray Dryer in either MANUAL or PROGRAM mode to control the shelf temperature to a set point value.

Operating the Stoppering Tray Dryer

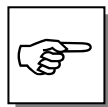

ALL ELECTRONIC CONTROL OF THE STOPPERING TRAY DRYER WILL BE DONE BY USING THE TOUCH SCREEN DISPLAY ON THE FREEZE DRYER BELOW THE TRAY DRYER.

The main features that are used to control the Tray Dryer will be described in this manual. For a complete description of the Freeze Dryer operating system, consult the Freeze Dryer User’s Manual.

Drying Accessory Screen

If the Stoppering Tray Dryer is NOT connected to the Freeze Dryer (via the communication cable), the Drying Accessory icon will NOT appear in the main menu bar. If the Stoppering Tray Dryer has been properly connected to the

Chapter 4: Using Your Stopping Tray Dryer

Freeze Dryer, the Drying Accessory icon will appear in the main menu bar and you will be able to control and monitor the Drying Accessory from this screen.

Drying Accessory	
Name	Value
System Temp	23.8°C
ST Dryer Vacuum	High
Sample 1	24.1°C
Sample 2	24.5°C
Sample 3	23.9°C
Drying Accessory OFF Data Log OFF	
<input type="button" value="PROGRAM"/> <input type="button" value="MANUAL"/>	

Drying Accessory Sensor Table – The middle section of the screen displays a list of all the sensors that are available for the connected Drying Accessory. Sensors that are disconnected will have three dashes (---) for their value.

Drying Accessory Status Box – The status box is located directly below the sensor table. The text on the left side will indicate the current operation mode of the Drying Accessory (OFF, Manual, or Program). When in Manual mode, the word “Manual” and the current Shelf Temp Set Point value will be displayed in this location. If a program is running the program name, Step #, and Time Remaining (TR) in the current Step will be displayed in this location. The right side of the status box will indicate if Data Logging is currently ON or OFF.

- **PROGRAM** – Pressing this button will take you to the Programs screen, where you can create a new program, or start, edit, view, copy or delete a saved program.
- **MANUAL** – Use this button to enter a Shelf Temp Set Point and/or start the Drying Accessory in manual mode.

Manual Mode

Manual mode can be used to control the System temperature to a single set point value between -40°C and +40°C. There is also a Max Cold setting that will turn off the heater control and allow the System to reach its lowest possible temperature (approximately -45°C).

Starting MANUAL Mode

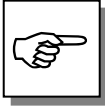

BEFORE STARTING THE TRAY DRYER, ENSURE THAT THE COLLECTOR IS “ON” AND HAS COOLED TO -40°C OR BELOW.

1. Turn the Stoppering Tray Dryer power switch ON. The POWER / STANDBY LED Indicator will turn ON.
2. On the Freeze Dryer display, go to the Drying Accessory screen
3. Press the “MANUAL” button
4. Enter a Set Point value between -40°C & $+40^{\circ}\text{C}$ (or select Max Cold), then press “Start”.
5. The Tray Dryer refrigeration system will start and the IN PROCESS LED Indicator will turn ON.

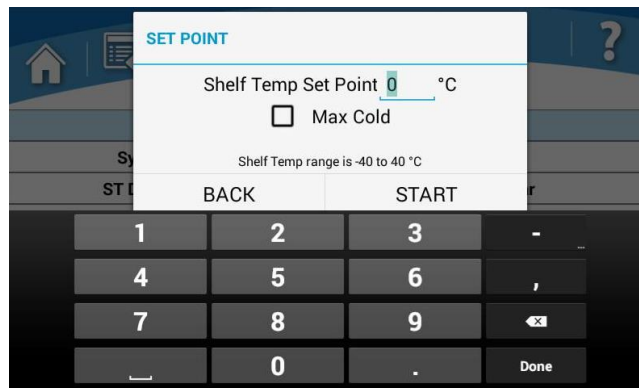

Changing the Shelf Temp Set Point Value

If the Tray Dryer is already running in MANUAL mode and you want to change the current Shelf Temp Set Point value:

1. Go to the Drying Accessory screen.
2. Press the “MANUAL” button.
3. Enter a new Set Point value and press “Apply”.

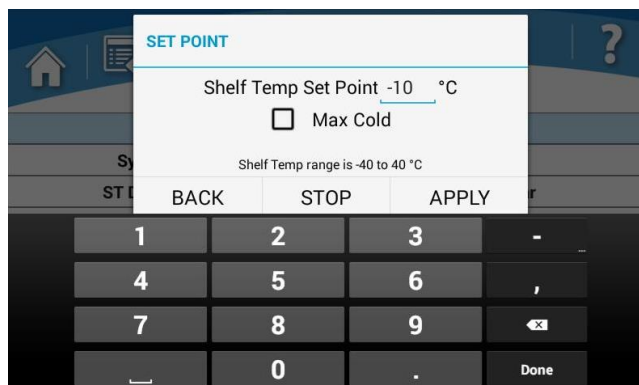

Chapter 4: Using Your Stopping Tray Dryer

Stopping MANUAL Mode

1. Go to the Drying Accessory screen
2. Press the “MANUAL” button
3. Press the “Stop” button
4. The Tray Dryer refrigeration system will stop and the IN PROCESS LED Indicator will turn OFF.
5. Turn OFF the vacuum pump
6. Position the “Vac Release” valve to OPEN.
7. Allow the vacuum to bleed to atmospheric pressure, then open the door and remove the samples.
8. Turn OFF the Freeze Dryer collector, defrost the ice, drain the collector chamber and dry.

Programs

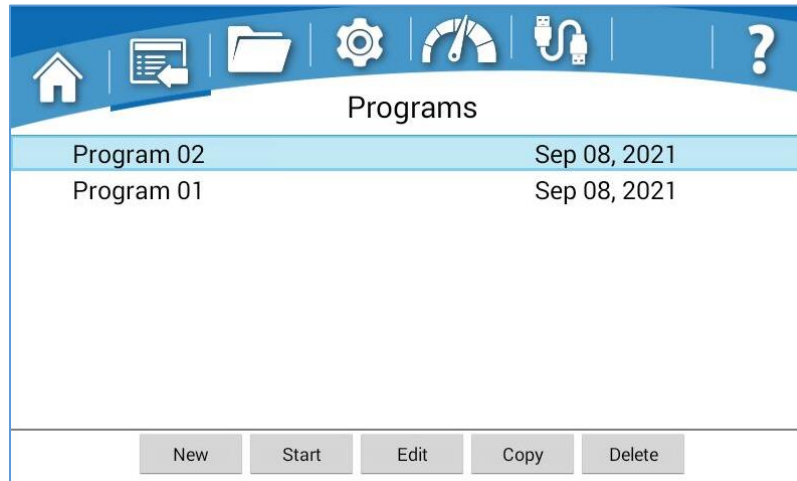

The Programs screen will allow you to create and store programs that are used to control the shelf temperature and vacuum level. Programs can be designed that take the product through pre-freezing, primary drying, and secondary drying phases.

When no program has been selected the “New” button will be the only active button along the bottom of the screen. A program can be selected from the program list by pressing the program name. When a program has been selected, the program row will be highlighted (blue). With a program selected, the rest of the buttons along the bottom of the screen will become active (Start, Edit/View, Copy & Delete).

- **New** – Use this button to add a new program to the program list. The new program name will be defaulted to a two-digit sequential number (starting with “Program 01”) that will be incremented as new programs are added to the list (i.e., Program 02, Program 03...). The default name can be edited as desired in the New or Edit screen.
- **Start/Stop** – Use this button to start or stop a program. The wording on this button will change from “Start” to “Stop” depending on whether a program is currently running.

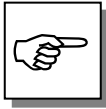

THE TRAY DRYER MUST BE ATTACHED TO THE FREEZE DRYER (VIA THE COMMUNICATION CABLE) TO RUN A PROGRAM. IF IT IS NOT ATTACHED TO THE FREEZE DRYER, THE START BUTTON WILL BE INACTIVE.

- **Edit/View** – Use this button to Edit or View the parameters of a saved program (the wording on this button will change from “Edit” to “View” depending on whether the program is locked or unlocked for editing).
- **Copy** – Use this button to Copy a selected program. The default name will be “*Program Name_copy*”. The program name can be edited as desired.
- **Delete** – Use this button to delete a saved program from the list.

When a program is currently in progress, a “running man” icon will appear to the left side of the program name. If the running program is selected (highlighted), the “Stop” button will be active, and the “Delete” button will be inactive.

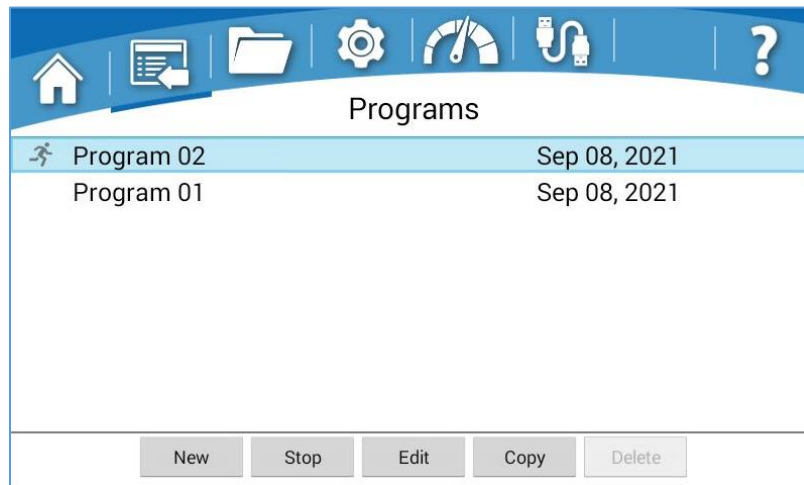

Chapter 4: Using Your Stoppering Tray Dryer

Creating a New Program

When the “New” button is selected, the following screen will be displayed.

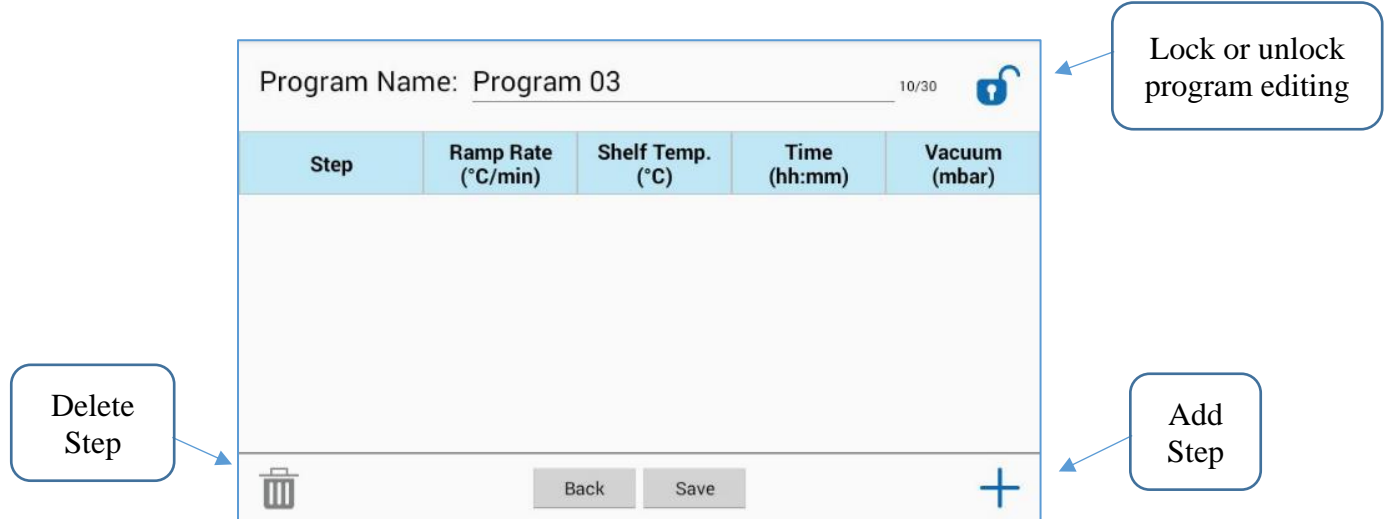

Pressing the program name field will allow you to edit the program name. The “Add” button will add a new Step to the program and take you through a series of screens to set the Ramp Rate, Shelf Temp., Time, and Vacuum. Values can be edited by pressing any of the cells. Pressing the “Delete” button will delete the selected step from the program. Changes will not be saved until the “Save” button is pressed. Pressing the “Back” button will return to the Programs screen without saving changes.

- **Ramp Rate** – This allows the temperature of the system to be increased or decreased at any desired rate within the capacity of the heating and cooling systems of the Stoppering Tray Dryer. Without samples on shelves, the system is capable of cooling at a rate of approximately 0.5°C/min and can heat at approximately 1.3°C/min. The cooling ramp rate may be slower as the temperature approaches –40°C. Ramp Rate may be set anywhere from 0.05°C to 1.5°C/min.
- **Shelf Temp.** - May be set anywhere from +40°C to –40°C in 1°C increments. There is also a Max Cold (MC) setting that will turn off the heater control and allow the system to reach its lowest possible temperature (approximately -45°C).
- **Time** – This time represents how long the system will hold at the Shelf Temp. that has been programmed for each Step. The time can be set from 00:01 to 99:59 (1 min to 99 hrs 59 min). It can also be set to an indefinite amount of time, which is represented by the infinity symbol (∞).
- **Vacuum** – Vacuum control can be set from 0.000 to 1.500 mbar.

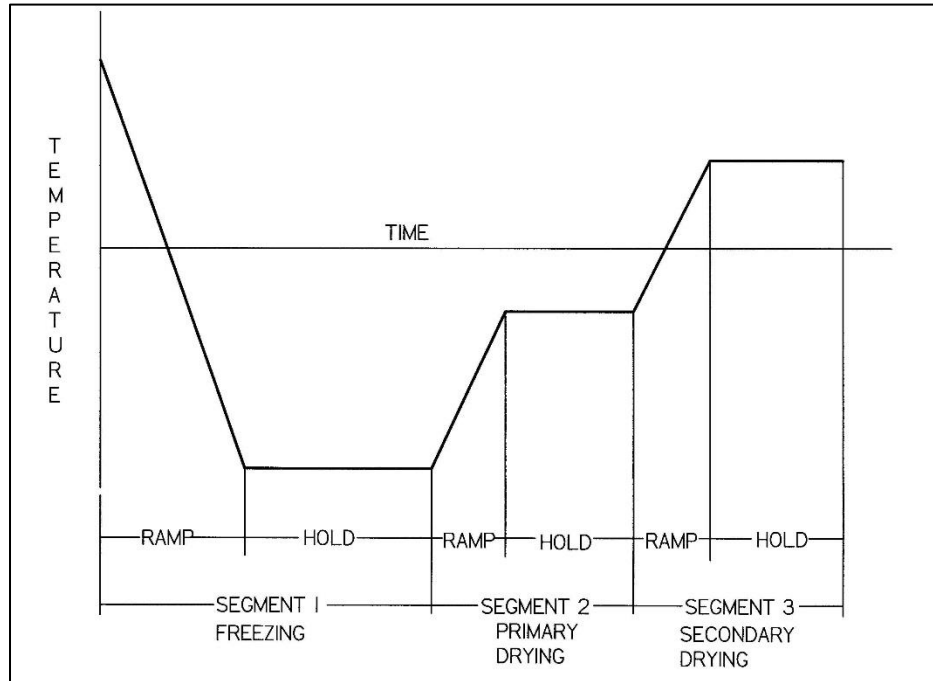
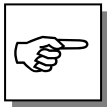

Illustration of a simple 3 Step Program

Starting a Program



BEFORE STARTING A PROGRAM, ENSURE THAT THE COLLECTOR IS “ON” AND HAS COOLED TO -40°C OR BELOW.

1. Go to the Programs screen. You can access the Programs screen in two different ways, both lead to the same location.
 - a. Directly access the Programs screen by selecting the Programs icon from the main menu bar at the top of the display.
 - b. Go to the Drying Accessory screen, then select the PROGRAM button at the bottom of the screen.
2. Select a program from the saved programs list, or create a new program.
3. With the desired program selected from the list, press the START button.
4. The Tray Dryers refrigeration system will start and the IN PROCESS LED Indicator will turn ON.

Stopping a Program

1. At the end of the last programmed step, the Stoppering Tray Dryer will turn OFF automatically. The IN PROCESS LED Indicator will turn OFF and a “Program Complete” alert will be displayed on the Freeze Dryer touch screen. The Freeze Dryer refrigeration (collector) and vacuum systems will continue to run until they are turned off by the user.

Chapter 4: Using Your Stoppering Tray Dryer

2. To stop before the completion of the last programmed step
 - Go to the Programs screen
 - Select (highlight) the program that is currently running
 - Press the STOP button
3. Turn OFF the vacuum pump.
4. Position the “Vac Release” valve to OPEN.
5. Allow the vacuum to bleed to atmospheric pressure, then open the door and remove the samples.
6. Turn OFF the Freeze Dryer collector, defrost the ice, drain the collector chamber and dry.

Freeze Drying Using the Manifold Valves

Some Tray Dryers are equipped with a 6-Port Manifold. The procedure below should be followed when freeze drying samples using the manifold.

1. Close and latch the Stoppering Tray Dryer door.
2. Set the Vac Release valve to CLOSE.
3. Pre-freeze samples - Shell freezing of samples is recommended.
Appropriate containers for freeze drying includes ampules, serum bottles, and wide mouth freeze drying flasks. Proper sample container size should always be at least two to three times the sample size (i.e., 150 ml samples should be prepared in 300 ml containers or larger).
4. Start the Freeze Dryer in either the Auto or Manual mode (See the Freeze Dryer User’s Manual)
5. Connect a pre-frozen sample to a valve on the manifold using an adapter. Some vials can be attached directly to the sample valve. Turn the plastic valve knob to the “VACUUM” position to open the valve, which connects the attached sample to system vacuum. The bevel on the knob should be positioned toward the sample port.

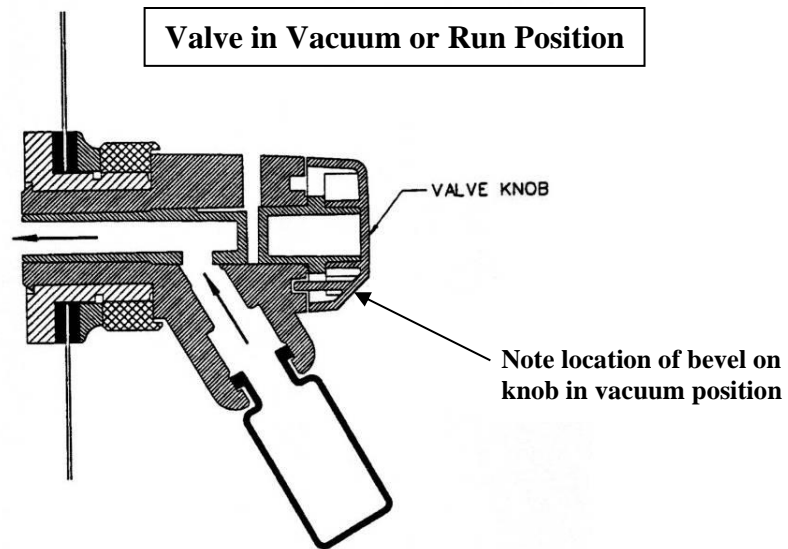

6. Before adding another sample, allow system vacuum to return to 0.133 mbar or lower. Any combination of valves and sample sizes may be utilized at one time provided that the system vacuum and collector temperature remain sufficiently low to prevent melting of the frozen sample.
7. When all the frost has disappeared from the outer surface of the sample container and no cold spots can be detected by handling the container, the sample is nearly dry. To be certain of low final moisture content, dry the sample for several hours past this point.
8. To remove a container after drying is complete, turn the plastic knob on the valve to the "VENT" position, which closes the valve and vents the container. Should backfilling with an inert gas be required, simply connect the gas supply line to the vent port on the valve. The sample container may now be removed. In the vent position the bevel on the knob should point away from the sample port.

Chapter 4: Using Your Stoppering Tray Dryer

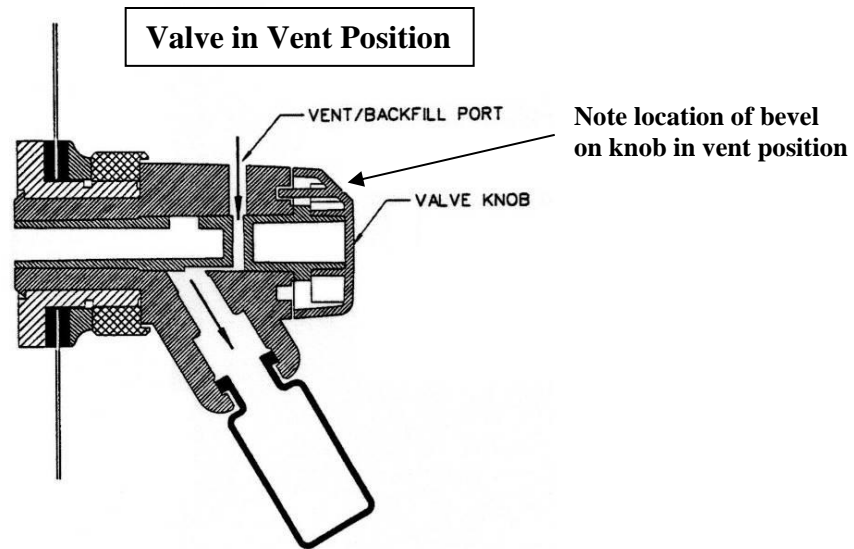

9. Ampules may be flame sealed while connected to a valve by using a sealing torch. Care must be taken not to burn the valve. An insulation material placed between the valve and the torch is recommended.
10. Shut off the Freeze Dryer, defrost the ice and drain the collector and dry. See the Freeze Dryer User's Manual.

Shelf Spacing Adjustment

Prior to loading the shelves with the product to be freeze dried, adjust the shelves to the 3-shelf, 2-shelf or 1-shelf position. It is best to observe the shelf supporting mechanism and practice while reading these procedures. In the 3-shelf position, the spacing between the shelves will accommodate a serum bottle with the stopper raised up to a maximum height of 75 mm (2.9 inches).

Minimum serum bottle height with lowered stopper for bottles on 3 shelves is 38 mm (1.5 inches).

For a 2-shelf system, grasp the top shelf and raise it until it latches in place. Then raise the middle shelf approximately 1 inch until it latches in a position to allow a two equally spaced shelf system. The spacing between shelves will accommodate a bottle with the stopper raised up to a maximum height of 107 mm (4.2 inches). Minimum serum bottle height with lowered stopper for a 2-shelf system is 56 mm (2.2 inches).

For a single shelf system, raise both the top and middle shelves until they latch in place in their top positions. The spacing for a single shelf system will accommodate a bottle with raised stopper up to a maximum height of 196 mm (7.7 inches), and the minimum height of a bottle with lowered stopper for successful stoppering is 114 mm (4.5 inches).

To unlatch the shelves, press the latch protruding from the side of the shelf support structure and move the latch until it clears the shelf and allows the shelf to drop. The top shelf has one latched position, the middle shelf has two latched positions, and the bottom shelf should not latch in any position.

Shelf Loading

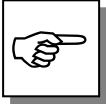

THE STOPPERING MECHANISM IS CAPABLE OF GENERATING A VERY STRONG FORCE, WHICH CAN DAMAGE THE SHELVES OR MECHANISM. THEREFORE, IT IS IMPORTANT TO DISTRIBUTE THE SERUM BOTTLES TO BE STOPPERED EVENLY ACROSS THE ENTIRE SURFACE OF EACH SHELF.

Your Stopping Tray Dryer has a unique system for keeping the shelves level and moving smoothly while stoppering. If a problem occurs during stoppering, the system is designed to flex a small amount to lessen the possibility of damage to the unit.

The stoppering action should be monitored by looking through the chamber door. Cease stoppering when all bottles appear stoppered or if a problem occurs. Distributing the serum bottles evenly on the shelves also aids in consistent drying of all serum bottles on each shelf.

Sample Freezing

Before the freeze dry process can occur, the products to be dried must be in a frozen state. This can be accomplished in a freezer separate from the Stopping Tray Dryer or on the shelves in the Stopping Tray Dryer. First the shelves should be adjusted to accept the size of the selected sample containers. If desired, place one temperature probe in a sample vial on each shelf. Sample freezing can be done in either the MANUAL or PROGRAM mode.

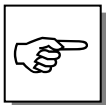

THE VACUUM SHOULD ALWAYS BE TURNED OFF WHILE USING THE SHELVES TO FREEZE SAMPLES

In MANUAL mode, simply set the Shelf temperature to the desired value for freezing the sample, and allow an appropriate amount of time for the sample to be fully frozen before starting the vacuum and the freeze drying process.

In PROGRAM mode, the vacuum set point can be programmed to OFF for the initial pre-freezing step. If multiple steps are desired for more complex pre-freezing/annealing processes, then program the vacuum set point to OFF for each of the pre-freezing / annealing steps.

Chapter 4: Using Your Stoppering Tray Dryer

Freeze Drying

Turn on the FreeZone Freeze Dryer. See Freeze Dryer User's Manual for complete instructions on operating the Freeze Dryer. Following the instructions for the unit, this may be accomplished in either the auto or manual mode.

When the Freeze Dryer collector temperature is less than -40°C and the vacuum has reached the desired level, the MANUAL mode set point temperature may be adjusted or PROGRAM mode may be initiated. At no time during the primary drying phase should the product temperature be allowed to rise higher than the eutectic temperature.

The ice collecting coil temperature and the vacuum level should be monitored. Higher than desired collector coil temperature or vacuum levels will inhibit or ruin the freeze dry process.

Stoppering

The stoppering operation (when desired) is performed after the freeze dry process is complete. To stopper, move the Stoppering control toward the "RAISE" position. This action allows the bladder beneath the bottom shelf to inflate causing the bottom shelf to rise. The vials on the shelf will then contact the middle shelf causing it to rise and the top shelf will eventually be contacted and rise. When all three shelves have raised and made contact with each other, stoppers will be pressed into the vials. Monitor the stoppering process by looking through the chamber door.

When all of the vials appear to be stoppered, move the Stoppering control to the "LOWER" position. This opens the bladder to the vacuum pump, which will cause it to deflate. Opening the vacuum release valve also deflates the stoppering bladder. The Stoppering control should be left in the "LOWER" position when not stoppering.

Vacuum Break/Backfilling

To open the chamber door, the vacuum must be released. To release the vacuum, move the Vacuum Release valve to the "OPEN" position and turn off the vacuum from the Home screen on the Freeze Dryer.

Air enters the vacuum chamber through the Back Fill port. When the sound of air through the Back Fill port is no longer audible, the chamber door is ready to open.

To backfill the chamber with a gas, connect a cylinder of the desired gas to the Back Fill port. The port will accept 1/8" tubing. The bottle must be equipped with a regulator set to 15 psi maximum. The gas can be metered with the Vacuum Release valve and chamber pressure monitored on the Freeze Dryer control panel. Allow the vacuum pump to run for a few minutes while the gas enters to permit the back fill gas to surround the freeze dried sample. When the

vacuum pump is turned off, air will enter the system through the vacuum break valve located between the vacuum pump and the collector chamber.

Alerts

A number of events may occur during a lyophilization procedure that will cause an alert to be displayed on the Freeze Dryer touch screen. An audible alarm (beeper) will also be sounded that will automatically be muted after one minute. The specific alert type can be identified by observing the message box on the Freeze Dryer display. The alert message box and audible alarm can be dismissed by pressing the “Back” button on the alert message box. The following conditions will initiate an alert:

Power Fail

If a power failure to the Stoppering Tray Dryer occurs while a run is in progress, the “Power Fail – ST” alert will be displayed when power is restored. If the failure is of a short duration and the Freeze Dryer collector does not warm up above -30°C , when power is restored the Freeze Dryer and Stoppering Tray Dryer will restart and resume operation of the refrigeration and vacuum systems. If the power failure lasts for a longer duration and the collector warms above -30°C , when the power is restored, the Freeze Dryer will not automatically restart. This prevents melted sample from being drawn into the collector and prevents liquid from being drawn into the vacuum pump.

Line Voltage Range

If the voltage supplied to the Stoppering Tray Dryer varies beyond allowable limits, the “Line Voltage Range – ST” alert will be displayed. The high and low alarm points are preset at the factory to correspond to the normal allowable voltage variations based on the nominal voltage specified for the freeze dryer. Some models may be operated outside the normal voltage limits (see *Appendix C*). If necessary, the high and low LINE VOLTAGE OFFSETS may be adjusted from the Settings / Maintenance screen.

System Temp Variation

Once the system temperature has stabilized (held set point temperature within $\pm 2^{\circ}\text{C}$ for 20 minutes), if the manual set point temperature or program hold temperature varies more than $\pm 2^{\circ}\text{C}$ from the set point (as measured by the system temperature sensor), the “System Temp Variation” alert will be displayed.

Vacuum Variation

Once the system vacuum has stabilized at a point where it changes less than 0.020 mbar in 5 minutes, if the vacuum changes more than 0.500 mbar, the “Vacuum Variation” alert will be displayed.

Chapter 4: Using Your Stoppering Tray Dryer

System Temp Set Point

If during a Ramp segment the system temperature stabilizes without reaching the Shelf Temp Set Point, the control will automatically enter the next Hold segment and the “System Temp Set Point” alert will be displayed.

Program Complete

When the last step of a running program has been completed, the “Program Complete” alert message will be displayed.

CHAPTER 5

MAINTAINING YOUR STOPPERING TRAY DRYER

Service Safety Precautions



- Always ensure that only authorized technicians service the refrigeration, vacuum and electrical systems.
- If performing any electrical maintenance, always disconnect the power at the main disconnect.
- If the refrigeration system must be operated with access panels removed (for diagnostic purposes only), stay clear of moving fan blade.
- Always practice team lifting when moving heavy equipment.
- After servicing, verify that all access panels or covers are in place before resuming normal operation of the equipment.

Routine Maintenance Schedule

Under normal operation, the Stoppering Tray Dryer requires little maintenance. The following maintenance schedule is recommended:

As needed:

1. The user has the responsibility for carrying out appropriate decontamination if hazardous material is spilled on or inside the equipment. This may be done by wiping the contaminated surfaces with a soft cloth dampened with alcohol. Alcohol may craze the acrylic door. Before using any cleaning or decontamination method except those recommended by Labconco, users should check with Labconco that the proposed method will not damage the equipment.
2. Clean up all spills; remove liquids from the chamber.
3. Clean door and gasket using soft cloth, sponge or chamois and a mild, non-abrasive soap or detergent.

Chapter 5: Maintaining Your Stoppering Tray Dryer

4. Check oil level of the vacuum pump. It should be between MIN and MAX. If the oil level is less than an inch (25.4 mm) above MIN, add oil to proper level.
5. If oil shows cloudiness, particles or discoloration, drain the pump and replace with fresh oil.
6. **Utilization of acids requires immediate cleaning and neutralization after a run or physical damage will result.**

Monthly:

1. The rubber components on the Stoppering Tray Dryer may eventually deteriorate and require replacement. The effective life of rubber parts depends upon both their usage and the surrounding environment. Check all rubber hoses and gaskets and replace any that show signs of hardening, permanent set or deterioration.
2. Using a soft cloth, sponge or chamois and a mild, non-abrasive soap or detergent, clean the acrylic door.
3. Using a soft cloth, sponge, or chamois and a mild, non-abrasive soap or detergent, clean the exterior surfaces of the unit. Liquid spray cleaners and polishes may be used on the exterior surfaces. Do not use solvents to remove stains from the exterior surfaces as they may damage the finish.

Annually:

1. Every 12 months, or more often if the Stoppering Tray Dryer is operated in a dusty environment, the refrigeration system condenser should be cleaned. Using a vacuum cleaner with brush attachment, clean the condenser to ensure proper airflow for peak performance.

Decontamination

When freeze drying biological substances, it may be necessary to decontaminate the system. A surface decontaminant should be used to clean the accessible surfaces. The use of ethylene oxide is not recommended because of its hazardous and corrosive nature. Contact Labconco for additional information.

CHAPTER 6

TROUBLESHOOTING

Refer to the following if your Freeze Dry System fails to operate properly. If the suggested corrective actions do not solve your problem, contact Labconco for additional assistance.

FreeZone Freeze Dry Systems that are clean and dry and without samples attached should reach a vacuum of 0.133 mbar within 30 minutes and should achieve an ultimate vacuum of 0.040 mbar within 18 hours when the refrigeration is operating. If the Freeze Dry System does not obtain a satisfactory vacuum, perform the following maintenance tests.

Vacuum Pump

First make sure that the vacuum pump operates. If it fails to operate, check the electrical connections of the Freeze Dry System to the power source and then check the electrical connection of the vacuum pump to the Freeze Dry System. If the vacuum pump has a power switch, make sure that it is turned on. If the vacuum is not adequate when the vacuum pump is operating, proceed with the following steps:

1. Check the oil and ensure it is clear and clean. If the oil looks cloudy or has any particulates, replace the pump oil. Sometimes it may be necessary to flush the pump with clean oil several times. To flush the pump, run the pump 5 to 10 minutes to allow the oil to warm up. Drain the oil and refill with clean oil. Repeat as necessary.
2. Check the oil level in the pump. Ensure it is filled to the correct level.
3. Check vacuum hose connections from the pump to the Freeze Dryer and try running the unit.

Chapter 6: Troubleshooting

If vacuum problems continue, consider obtaining a second vacuum gauge capable of reading a vacuum of 0.010 mbar. It is often useful in determining if the vacuum pump is operating properly and the vacuum sensor reading is accurate.

4. Isolate the pump by disconnecting the vacuum hose from the Freeze Dry System. Deadhead the pump by inserting the vacuum sensor from a secondary vacuum gauge into the end of the vacuum hose and observe the vacuum reading obtained. Confirm that the pump is capable of achieving an ultimate vacuum less than 0.010 mbar or approximately 10 microns. If an inadequate vacuum reading is obtained, the pump has most likely failed and may need to be replaced or rebuilt.

Gaskets, Tubing, Connections, Sample Valves

1. Check all sample valves on the optional 6 port manifold (if installed) and ensure all valves are closed or in the vent position.
2. Check the drain line on the Freeze Dryer and ensure that the quick connect drain fitting is disconnected from the quick connect drain coupling.
3. Check all rubber vacuum tubing for signs of deterioration or cracking.
4. Check all connections and make sure they are secure and leak tight.
5. Check the Freeze Dry System collector lid gasket and the Stoppering Tray Dryer door gasket for indentations, cracks or tears. Clean gaskets using a soft, lint free cloth or paper towel.
6. The Stoppering Tray Dryer chamber and base unit collector chamber must be dry.
7. When checking the sample valves, (if the system is so equipped), pull as much vacuum as possible. If a vacuum indication is displayed, wiggle or rotate the valves and watch the gauge for any fluctuations. Fluctuations can indicate a potential vacuum leak. If the valve seems to be in good condition, remove the valve and apply a thin coat of vacuum grease to the stem and the outside sealing surface of the valve body, and reinstall the valve. If the valve still seems to be the source of the problem, remove the valve and stopper the hole with a rubber stopper (#6). Continue checking the other valves.

The illustration below shows how the sample valve installs on a manifold.

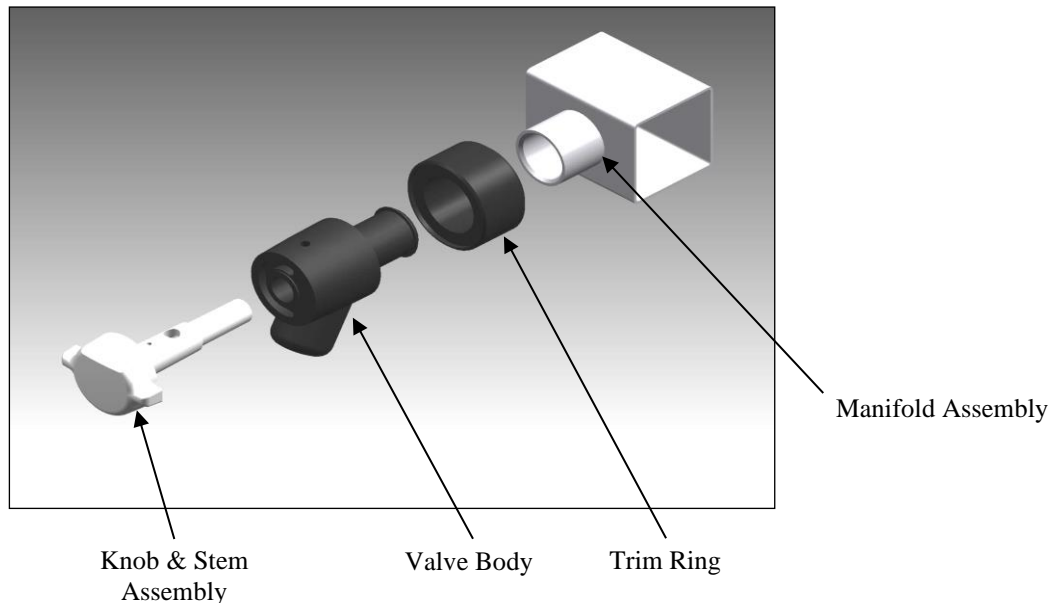

System Components and Collector Chamber Isolation

The following test allows you to check the pump and the connections from the pump to the vacuum tube.

1. Insert a rubber stopper (#2) in the vacuum port in the left side of the collector chamber.
2. Restart the vacuum system and check your vacuum indication. Insufficient vacuum indicates a bad pump or a leak in the connections from the pump to the side of the chamber.
3. Remove #2 stopper after completing test.

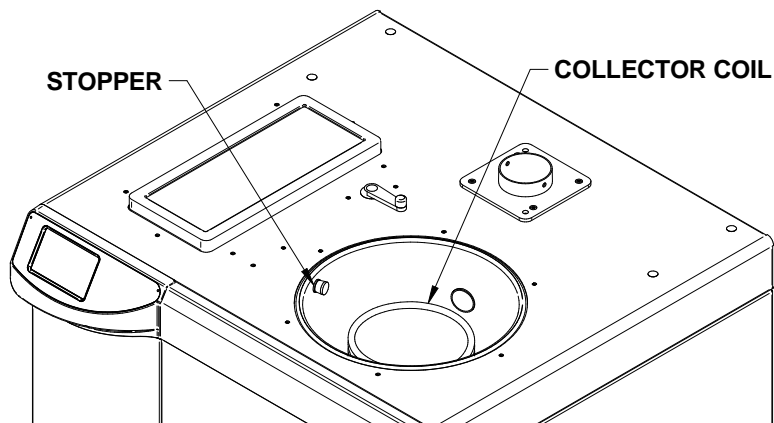

Chapter 6: Troubleshooting

The next test will allow you to determine if the vacuum leak is in the Stoppering Tray Dryer or in the Console Freeze Dryer.

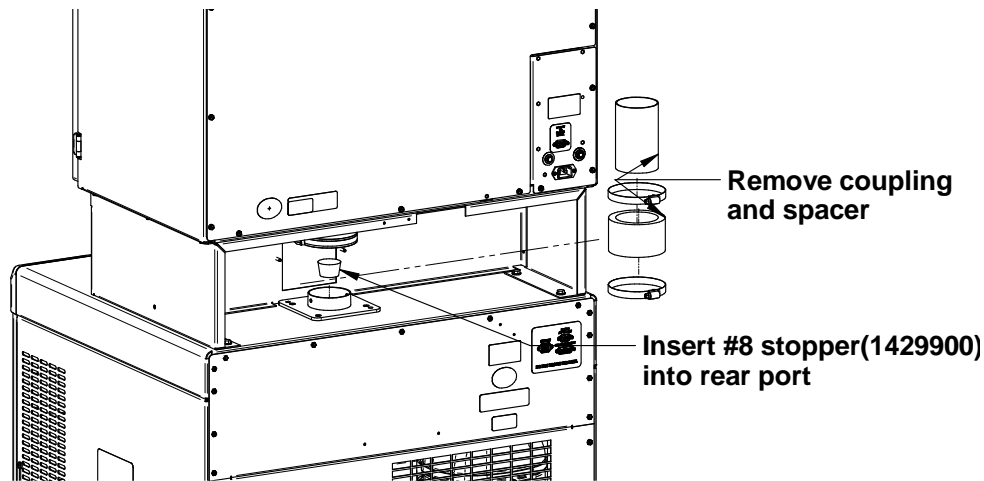

1. Remove the coupling and spacer connecting the Tray Dryer to the Freeze Dryer.
2. Insert a #8 stopper into the rear port.
3. Start the vacuum pump and observe the vacuum indication. If the vacuum indication is good, then the problem is in the Tray Dryer and you should proceed to Section IV. If the vacuum is insufficient then the leak is the Freeze Dryer. All easily accessible connection should be checked first for leaks. The figure below points out more difficult areas to check for leaks.

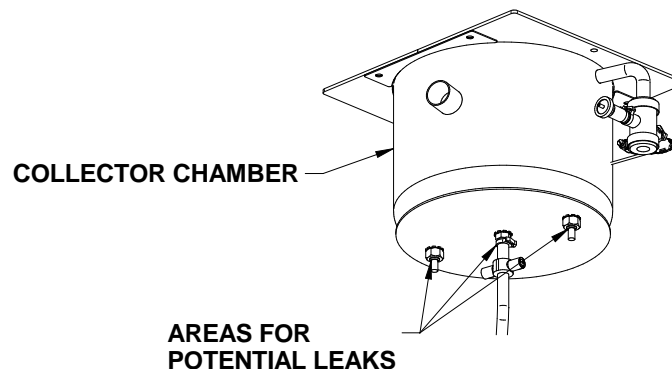

4. If a leak is observed around the bulkhead fittings (where the legs of the collector coil pass through the bottom of the collector chamber), access the bottom of the chamber and remove the insulation. Tighten the appropriate fitting by placing a wrench on the fitting inside the chamber and use a second wrench to turn the nut on the bottom of the chamber. Be careful not to damage the evaporator coils or the brazed joints to the refrigeration system. Once the fitting is tightened, perform the test again. If a leak is

still present at the bulkhead fittings, loosen the bulkhead fittings and apply vacuum grease to the O-rings, then reassemble and test.

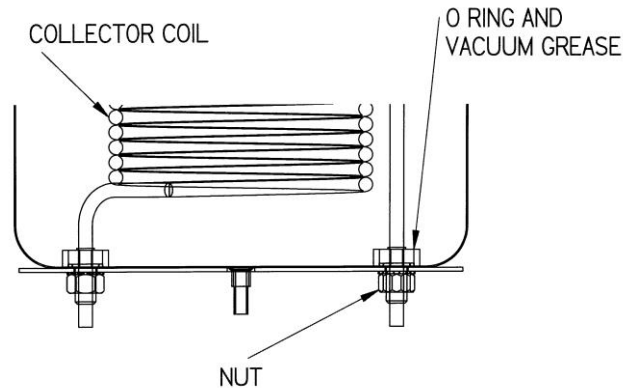

Stoppering Tray Dryer

- Inspect the door and door gasket.
- Inspect the coupling between the freeze dryer and the Stoppering Tray Dryer.
- Remove the top left hand cover panel and inspect the valve and hose connections to the chamber.
- Remove the top right hand cover and inspect the electrical pass through and gasket on the top of the chamber.

Door Adjustment

The following adjustments can be made if the door is not sealing properly when vacuum is applied.

1. The latch can be adjusted to increase the force between the door gasket and chamber sealing surface.
 - a. Open the door.
 - b. Using two ½" wrenches, loosen the nuts securing the latch pawl.
 - c. Move the latch pawl towards the door to tighten the latch.
 - d. Tighten the nuts.
2. The door hinges can be adjusted to move the door in towards the chamber sealing surface.
 - a. Loosen the screws to the hinge covers and rotate the hinge cover out of the way.
 - b. Turn on the vacuum pump using the Freeze Dryer controls.
 - c. After the vacuum level reaches approximately 5 mbar, loosen the six screws on the door hinges. **Do not remove the screws.**

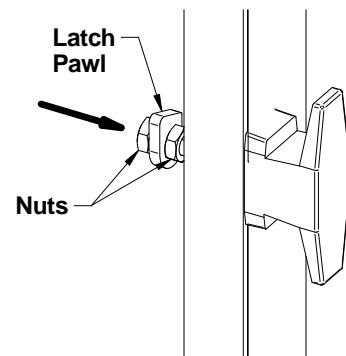

Chapter 6: Troubleshooting

- d. Once the vacuum level reaches approximately 1mbar, tighten the six screws.

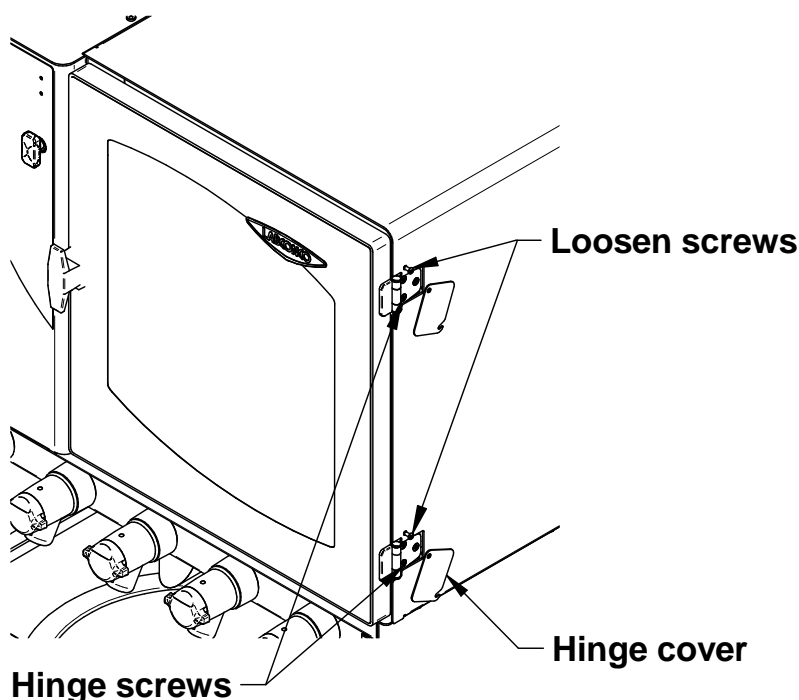

Refrigeration Module Operation

Under a no-load condition and depending on the ambient room temperature, the Stopping Tray Dryer can achieve a system temperature of -40°C or lower within 4 hours when the vacuum pump is running.

If any repairs are required on the refrigeration module, contact your local laboratory supply dealer. If your laboratory supply dealer is unable to provide assistance, please call Labconco. Repairs should only be undertaken by a competent refrigeration technician or through an authorized Labconco service agency.

Access to Mechanical Components

To gain access to the refrigeration system, pump, tank, and the controller and control panel components, it is necessary to remove the cover on the left side.

1. Loosen the set screw in each valve knob (using a $5/64$ hex wrench) and remove the knobs from the valve stems.
2. Remove (3) hex head screw along the bottom edge of the stainless steel front panel.

3. Grasp the left and right edges of the front panel and pull forward to release the spring loaded latches that hold the panel in place.
4. Disconnect the ribbon cable from the connection at the PC board.
5. Disconnect the wires to the power switch.
6. Remove (2) Phillips head screws from the top.
7. Remove the screws securing the left cover to the rear panel and the base plate and remove the left cover.

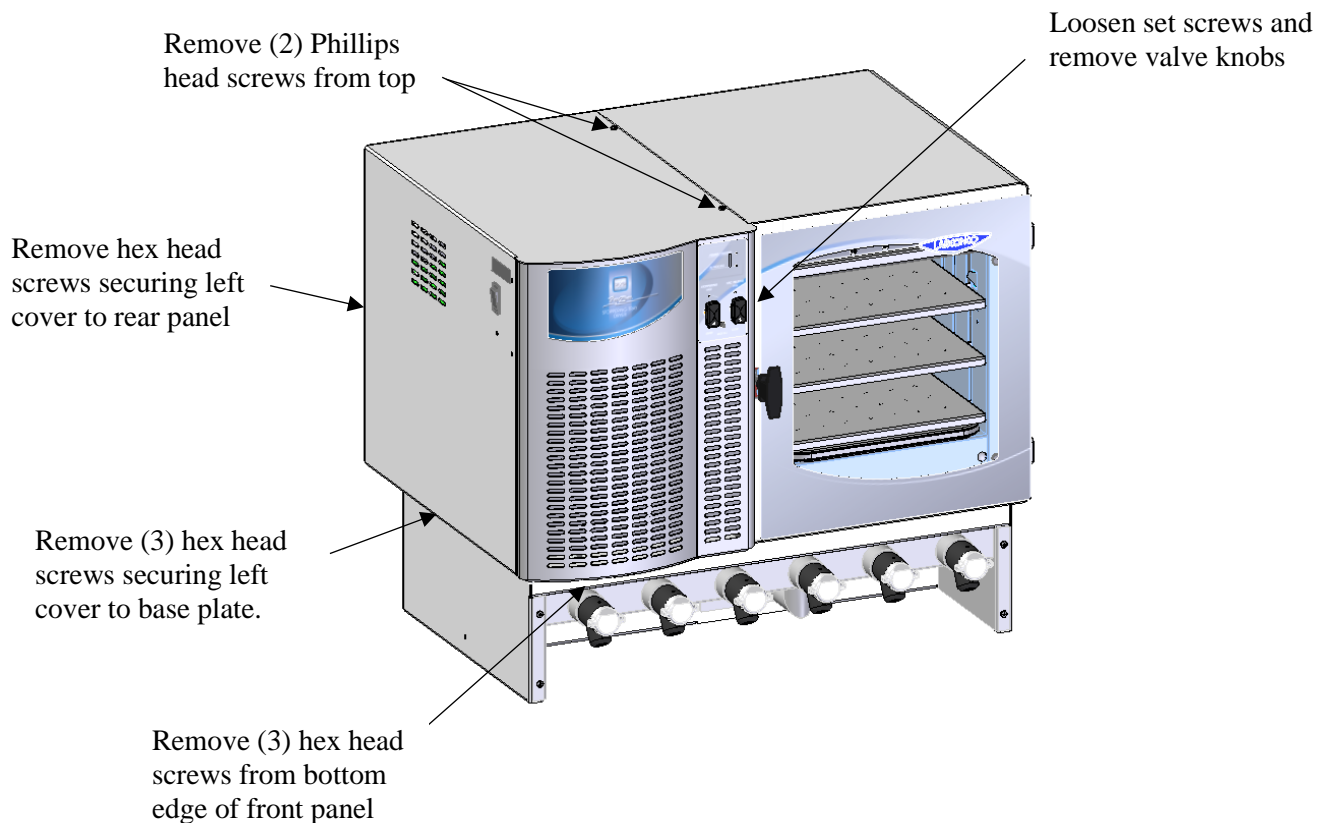

Shelf and Stoppering System Removal

1. The shelf and stoppering system may be removed from the chamber as an assembly for repairs if needed.
2. Place a support in front of the chamber and slide the shelf and stoppering system out approximately 2 inches.
3. Loosen the clamp securing the stoppering diaphragm tube (located in the lower center at the back of the chamber) and remove the tube. Slide the assembly out of the chamber and onto the support.

Chapter 6: Troubleshooting

4. The assembly is now ready for repairs. Whenever possible, do not break the fluid system.
5. Reverse the removal procedures for installation of the shelf and stoppering system. Make sure the fluid inlet and outlet tubes are routed on top of the assembly.

Filling the Fluid System

1. Fluid Circulation Valve
2. Fluid Reservoir and Cap
3. Electrical Junction Block
4. Flexible Tubing

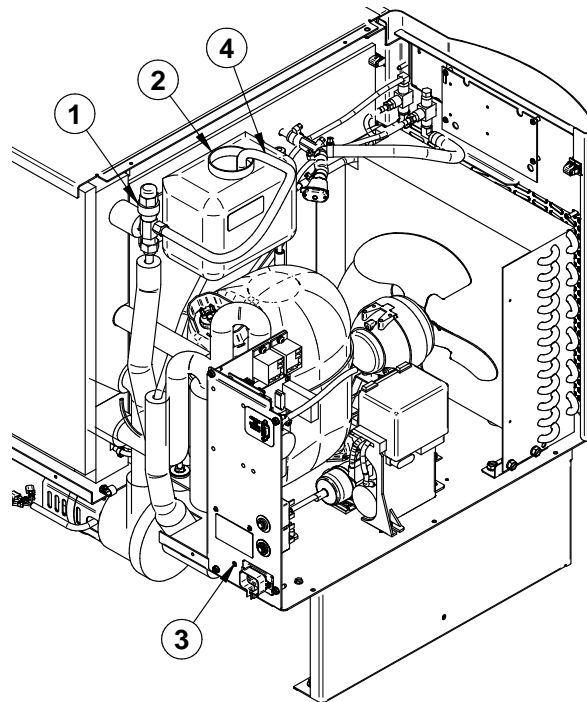

1. Make sure the Power Switch is in the OFF position.
2. Remove the left cover.
3. Remove the insulation and both caps from the fluid circulation valve, which is located directly behind the fluid reservoir.
4. Attach a flexible tube to the exposed port (service port) of the fluid circulation valve. The port is 3/8" x 45° male flare.
5. Remove the fluid reservoir cap and place the opposite end of the tubing into the fluid reservoir.
6. Fill the reservoir slowly allowing the fluid to drain through the system. When the system appears full, prepare to start the circulation pump.

7. Open the fluid circulation valve by completely “down-seating” (turn top valve stem completely clockwise) to direct fluid to by-pass through tubing to fluid reservoir.
8. Temporarily re-install the left cover and secure it to the base plate with (3) hex head screw. Attach the power wires to the power switch. Turn the power switch ON, and start the Stoppering Tray Dryer in Manual mode with Shelf Temp Set Point at 24°C (75°F). The fluid system will circulate with the fluid going through the by-pass tubing, purging itself of air. Add fluid as needed to keep fluid in the reservoir. Allow the fluid to circulate until no air bubbles are seen coming through the by-pass tubing.
9. After the system is free of air, “up-seat” fluid circulation valve (turn valve stem completely counter-clockwise, closing the fluid/tubing by-pass).
10. When the system temperature stabilizes, add or remove fluid from the reservoir to the level indicated by the label.
11. Apply vacuum to the unit, and when the system is 0.133 mbar or less, install the cap on the tank.
12. Remove the tubing. Replace the caps on the valve and replace insulation and covers.

Heat Transfer Fluid Precautions

The fluid’s name and manufacturer are:

Name: Lexol 542
Manufacturer: Santa Barbara Chemical Co.
927 Indio Muerto
Santa Barbara, CA 93140
805-963-7793



WARNING: The fluid used for heat transfer in this system is combustible and hazardous. Leaks and spills should be attended to immediately.

Handling and Storage Precautions – Dirty Solvent: Store in accordance with all applicable regulations. Tighten caps and store in a cool area.

Precautions if Material is Released or Spilled: Spills should be contained immediately. Spills may be soaked up with absorbent materials, placed in closed containers, labeled, stored and disposed of properly. Persons performing this work should wear adequate personal protective equipment and clothing.

Disposal of Non-Recyclable Solvents: Dispose of in accordance with all federal, state, and local health and pollution regulations. Follow same guidelines as used when disposing kerosene.

Heat Transfer Fluid First Aid Procedures

Eye Contact: Immediately flush eyes with fresh water for at least 15 minutes. If irritation persists, get medical attention.

Skin Contact: Wash contaminated areas with soap and water. Remove contaminated clothing and footwear. Wash clothing before reuse. Discard footwear, which cannot be decontaminated. Medical attention may be required.

Inhalation: Remove patient to fresh air. If breathing stops, give artificial respiration. Get medical attention immediately, if required.

Ingestion: Get medical attention immediately. Do not induce vomiting.

APPENDIX A

COMPONENTS

The following pages list components that are available for your Stoppering Tray Dryer. The parts shown are the most common replacement parts. If other parts are required, contact Product Service.

Item	Qty	Part No.	Description
1	1	7592002	Compressor 115V – 60 Hz
		7592001	Compressor 230V – 50 Hz
		7592000	Compressor 230V – 60 Hz
2	1	7501900	Lexsol Pump 115V
		7501901	Lexsol Pump 230V
3	1	7510902	Heater 115V
		7510903	Heater 230V
4	1	7369300	Chamber Pass Thru Harness
5	1	7353302	Temperature Sensor - System
6	3	7365800	Temperature Sensor – Sample
7	1	7343800	Diaphragm
8	1	7351700	Door Gasket
9	1	1302301	Switch
10	2 Gal.	7766801	Heat Transfer Fluid (Not Shown)
11	1	7316200	Printed Circuit Board I/O
12	1	7162300	Vacuum Sensor
13	2	7684200	Coupling – Vacuum
14	4	1966900	Clamp Coupling
15	1	7367701	Door Assembly
16	1	7368000	Electrical Panel Assembly 115V
		7368001	Electrical Panel Assembly 230V
17	1	7364601	Communication Cable
18	1	1345701	Power Cord 230V 50Hz India
		1332601	Power Cord 230V 50Hz UK
		1332701	Power Cord 230V 50Hz China
		1336500	Power Cord 230V 50Hz EU
		1338002	Power Cord 230V 60Hz US
		1336400	Power Cord 115V 60Hz US
19	1	7356200	Ground Strap

Appendix A: Components

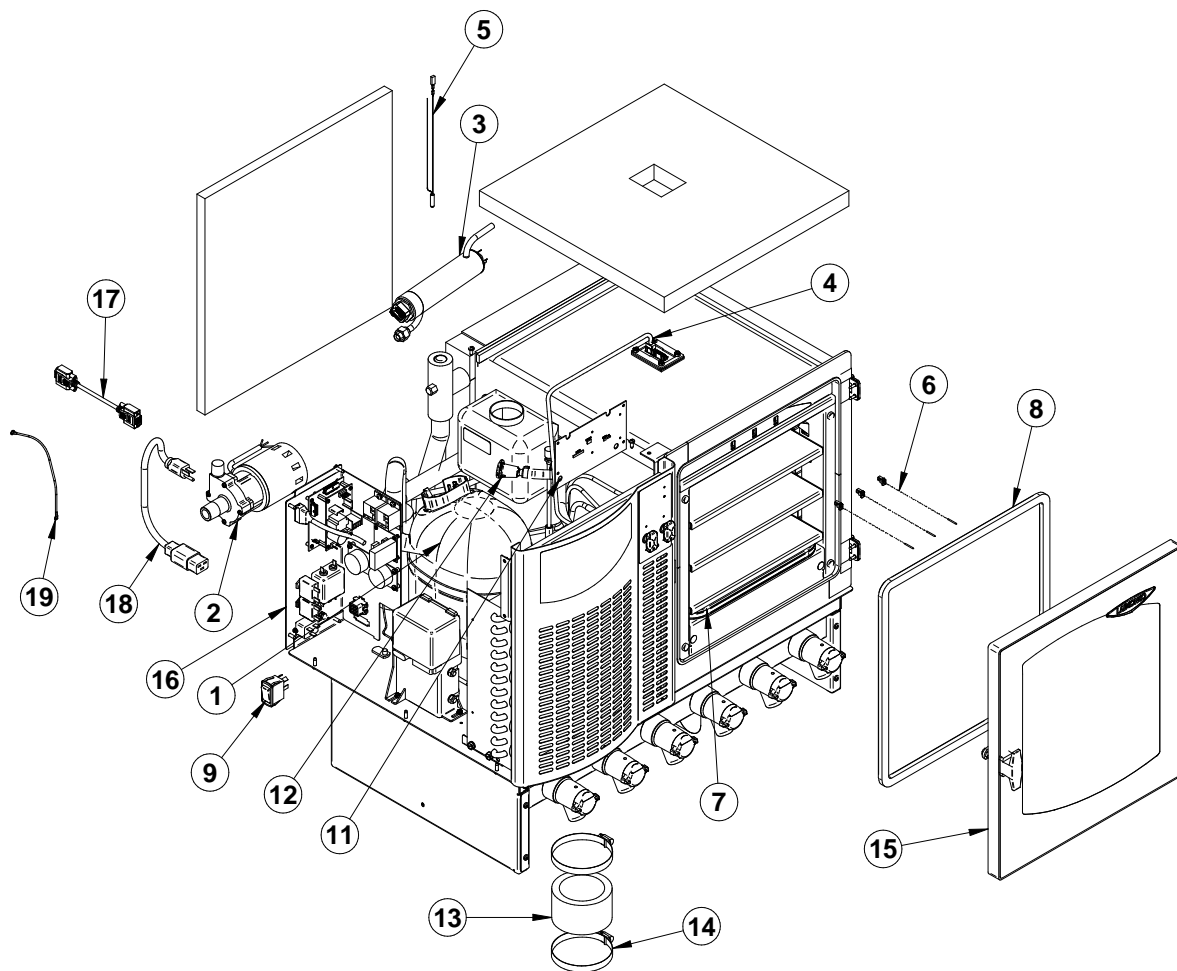

APPENDIX B

DIMENSIONS

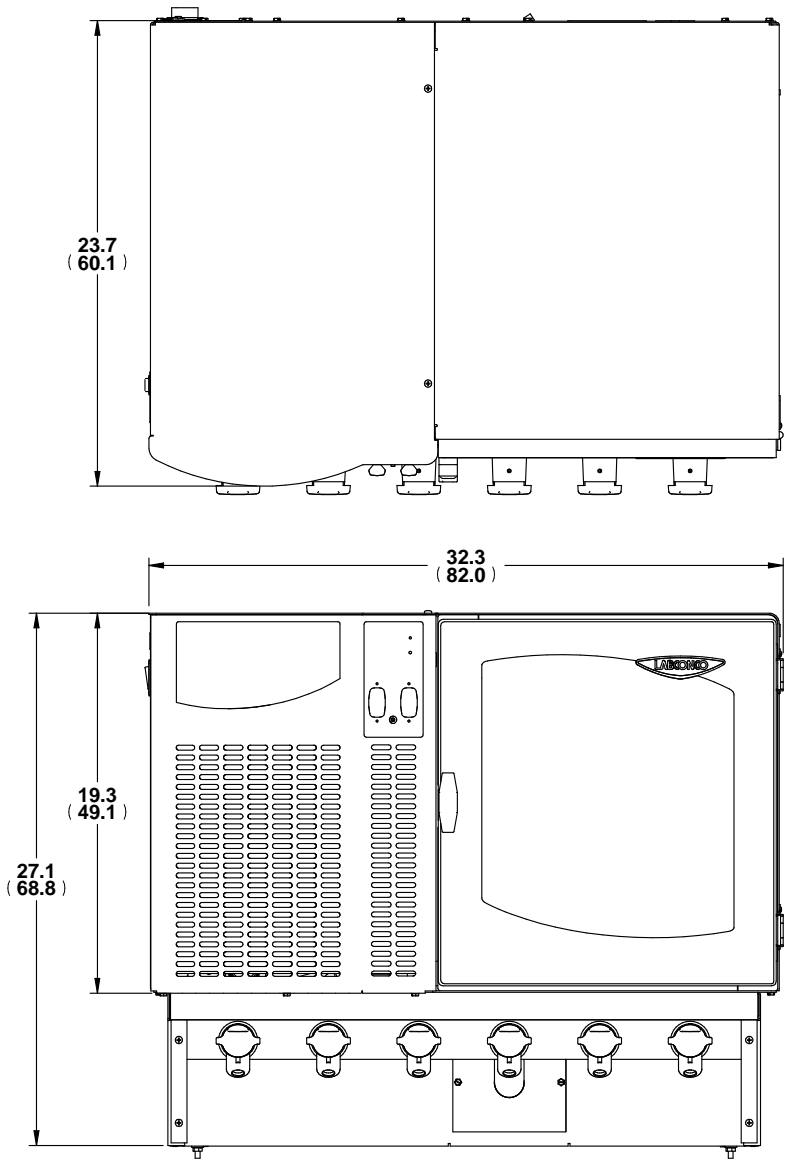

SHOWN WITH 6 PORT MANIFOLD
INCHES
(CENTIMETERS)

Appendix B: Dimensions

Serum Bottle Capacity of the Stoppering Tray Dryer

Size	Labconco No.	Shelf Capacity	No. of Shelves	Total Capacity
2 ml	7575010	430	3	1290
3 ml	7575210	483	3	1449
5 ml	7573010	255	3	765
10 ml	7573210	195	3	585
20 ml	7573410	132	3	396
30 ml	7573610	86	3	258
50 ml	7573810	72	2	144
100 ml	7574010	42	2	84
125 ml	7574210	36	1	36

APPENDIX C

SPECIFICATIONS

This Appendix contains technical information about the Freeze Dryer including electrical specifications and environmental operating conditions.

Electrical Specifications

Catalog #	Description	Voltage		Frequency	Current Rating
		Nominal	Operating Range	(Hz)	Amps
794801*00	Stoppering Tray Dryer	115V	103 - 127	60	16
794801*10 794801*15	Stoppering Tray Dryer	230V	187 - 253	60	9
794801*30 794801*40 794801*50 794801*70	Stoppering Tray Dryer	230V	207 - 253	50	9

(* represents 0, 1, 2 or 3 depending on optional factory installed features)

Environmental Conditions

- Indoor use only.
- Ambient temperature range: 41° to 104°F (5° to 40°C).
- Maximum relative humidity: 80% for temperatures up to 88°F (31°C), decreasing linearly to 50% relative humidity at 104°F (40°C).
- Main supply voltage fluctuations not to exceed $\pm 10\%$ of the nominal voltage.
- Transient over voltages according to Installation Categories II (Over voltage Categories per IEC 1010). Temporary voltage spikes on the AC input line that may be as high as 1500V for 115V models and 2500V for 230V models are allowed.
- Used in an environment of Pollution degrees 2 (i.e., where normally only non-conductive atmospheres are present). Occasionally, however, a temporary conductivity caused by condensation must be expected, in accordance with IEC 664.

APPENDIX D

ACCESSORIES

Labconco offers a full line of accessories to enhance your Stoppering Tray Dryer's operation and usability. For a complete list of these accessories, please consult our website at www.labconco.com.