



SAFETY ENCLOSURES, CLEAN BENCHES &  
NON-VENTILATED ENCLOSURES



Protecting your  
laboratory environment

**LABCONCO**

# PURIFIER® CLASS I & HEPA FILTERED SAFETY ENCLOSURES

## INTRODUCTION

Purifier Class I Safety Enclosures and Purifier HEPA Filtered Enclosures protect you and your laboratory environment. They are an economical alternative to Class II biosafety cabinets when your applications do not require product protection.

**Purifier Class I Enclosures protect the user from agents that require Biosafety Level 1, 2 or 3 containment but no product protection.** These enclosures include an ultraviolet light that may be used in conjunction with surface disinfection to ensure thorough decontamination. The UV light has an interlocking protection panel to ensure that the light operates only when the enclosure is not in use, to avoid personnel exposure to UV rays.

**Purifier HEPA Filtered Enclosures, which do not include a UV light, protect the user from hazardous chemical powders, dust and allergens in diverse applications ranging from screening suspicious mail to blending dry chemicals.**

For applications involving odor-generating materials, Purifier Class I and HEPA Filtered Enclosures may be outfitted with an accessory Trace Odor Carbon Filter to trap nuisance organic, formaldehyde or ammonia vapors. When connected to the accessory Canopy Connection and ducted outside to a remote blower or house exhaust, Purifier Class I and HEPA Filtered Enclosures may be used with fume-generating materials or agents that have been treated with toxic chemicals or radionuclides as an adjunct to research. These canopy-ducted enclosures have the added benefit of eliminating nuisance odors. Use of acids, which would corrode the internal blower within these enclosures, is prohibited. Contact Labconco for information on enclosures suitable for use with acids.



Purifier Class I Enclosure 3980303 on Solid Epoxy Dished Work Surface 3909901 and Telescoping Base Stand 3746711 with Ergonomic Chair 3744000.

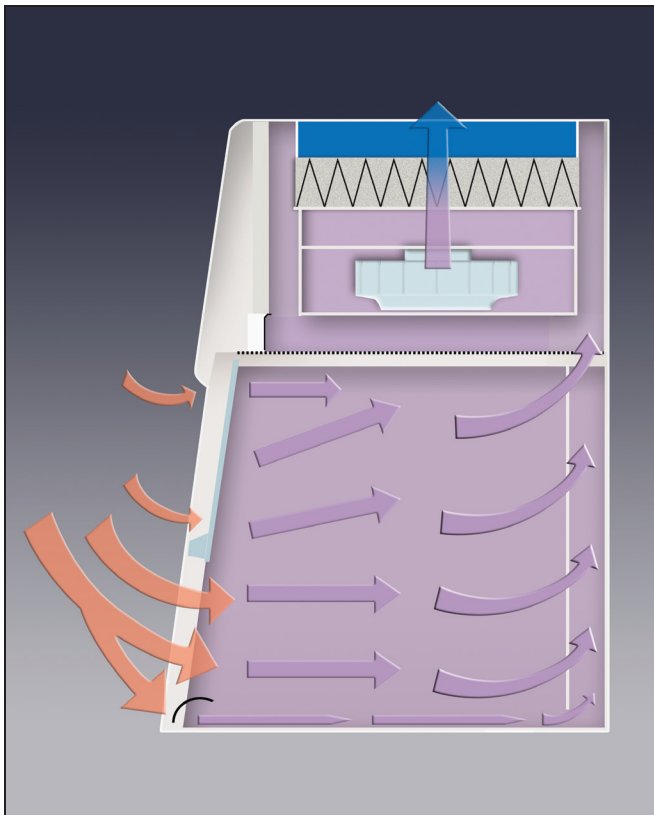

*During operation, room air is drawn into the front of the enclosure, preventing aerosols from escaping into the room. Before leaving the enclosure and returning to the environment, 100% of the air passes through an exhaust HEPA filter.*

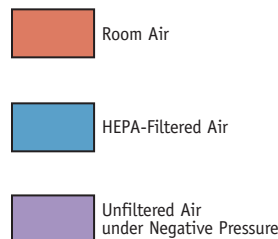

# PURIFIER® CLASS I & HEPA FILTERED SAFETY ENCLOSURES

## FEATURES & BENEFITS

**Built-in exhaust HEPA filter**, 99.99% efficient on 0.3 micron particles.

**Front-mounted differential pressure gauge** monitors pressure differential across the HEPA filter to help determine filter loading.

**Tempered safety glass front sash and sides** offer excellent visibility and protection. Glass has better fire, scratch and corrosion resistance than acrylic and dissipates static charge.

**Patented\* rear baffle with zones of perforations** promotes horizontal laminar airflow to maximize containment.

**Two utility ports with iris openings** allow passage of tubing and cords from inside to back exterior for connection to services.

**Patented\* Clean-Sweep™ air foil** allows air to sweep the work surface for maximum containment. Airflow openings pull inflow air from under the air foil so that clean air continually flows over the air foil creating a constant barrier of protection from contaminants.



**Sturdy powder-coated aluminum frame and steel rear plenum and baffle** dissipate static charge and provide durability and corrosion resistance.

**Space-saving design.** Impeller and HEPA filter are contained within the enclosure's upper plenum for a small overall footprint.

**Intrinsically-safe design.** The positive pressure impeller is surrounded by a negative pressure plenum so that if a leak should develop, the unfiltered air is captured and refiltered.

**Optional built-in Guardian™ Airflow Monitor** alerts the user to face velocities outside of preset range, indicating HEPA filter loading or blower malfunction.

**Glare-free fluorescent lighting.**

**Upper dilution air supply** introduces room air at the top of the sash to dilute concentrations in the upper chamber and bathes the back of the sash with clean air.

**Speed control** regulates speed of the built-in blower and may be used by a certifier to adjust and validate inflow velocity.

**Ergonomic 10° angled sash** allows a closer view, reduces glare and provides a more comfortable operating position than vertical sashes. The hinged sash pivots up and locks to a loading height of 20".

**254 nm UV light with interlocking UV protection panel** (Class I models only) for secondary decontamination while the enclosure is not in use. The UV light does not illuminate without the panel in place.

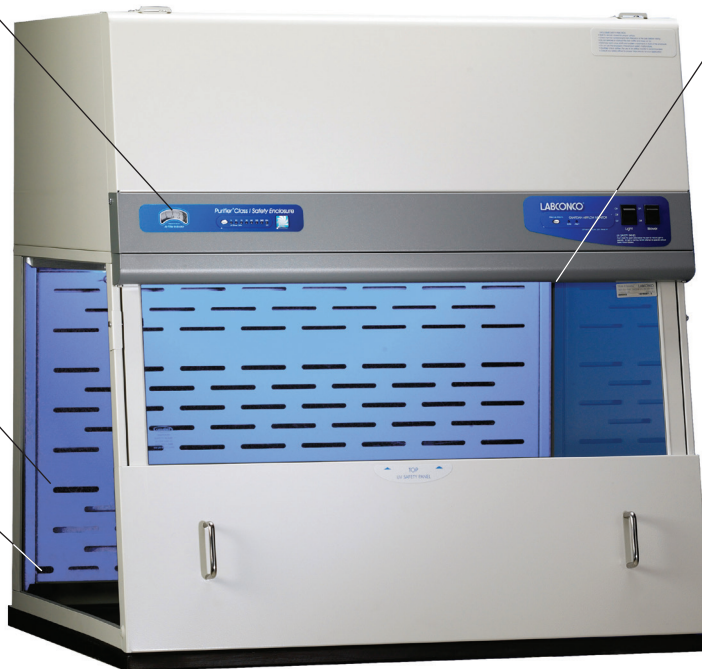

**Variable digital timer** provides timed UV light exposure (Class I models only). From the front-mounted control panel, the operator may select from eight settings in minutes of 5, 10, 15, 30, 60, 120, 240 and continuous.

**Side-entry air foils** allow air to sweep across the interior glass surfaces to enhance containment.

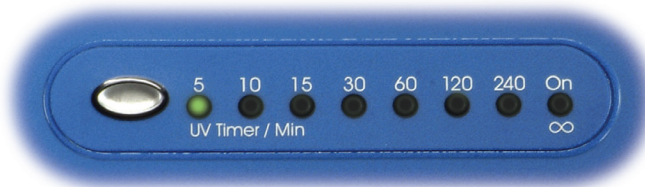

**Particulate containment** tested. Free validation package containing independent containment testing verification is available.

**Biological containment** verified per NSF Standard Number 49 Personnel Protection Test.

\* U.S. Patent No. 6,461,233

Exclusive feature

# PURIFIER® CLASS I SAFETY ENCLOSURES

## ORDERING INFORMATION

### Standard Features

- Nominal inflow velocity of 75 to 105 fpm
- ☒ Ergonomic air foil with aerodynamic Clean-Sweep\* airflow openings
- ☒ Upper dilution air supply
- ☒ Zone-perforated rear baffle\*
- ☒ Side-entry air foils
  - Exhaust HEPA filter, 99.99% efficient on 0.3 micron particles
  - Variable speed built-in blower with dynamically-balanced, vibration-isolated motorized impeller and solid state control rated for 5 amps
- Intrinsically-safe, negative pressure design
- Differential pressure gauge
- Low discharge volume and quiet operation (*see chart below*).
- ☒ Upper containment sash foil
  - Glacier white and gray powder-coated aluminum frame and steel rear plenum and baffle
- Fluorescent lamp
- 254 nm UV lamp with interlocking UV protection panel and two support hooks located atop the bench for stowing the panel.
- ☒ Variable digital timer for UV exposure with eight settings in minutes of 5, 10, 15, 30, 60, 120, 240 and continuous
  - Blower switch and 3-way light switch: UV, off and fluorescent
  - 1/4" thick tempered safety glass front sash and sides
  - 9.44" high sash opening
  - Ergonomic 10° angled and hinged sash that pivots upward, locks to a loading height of 20" and has side wiping seals
- Two utility ports with iris openings
- Particulate containment tested
- Biological containment verified per NSF Standard Number 49 Personnel Protection Test
- ASHRAE 110 conformity tested
- UL 61010-1 and CAN/CSA C22.2 conformity (115 volt models)
- CE Mark (230 volt models)
- One year warranty
- Validation package available



Purifier Class I Safety Enclosure 3980203 on Solid Epoxy Dished Work Surface 3909900 and Telescoping Base Stand 3746710.

### Standard Option

- Guardian Airflow Monitor that continuously monitors airflow and has two LED lights to indicate when airflow is within or outside set point range.

### Required Accessories

- Supporting work surface. Place on existing casework or see page 6.
- Supporting base. Place on existing casework or see pages 28-31.

See page 6 for dimensional drawings.

Catalog #	Nominal Width	Exhaust Volume	Electrical Requirements	Airflow Monitor	Power Cord & Plug	Shipping Weight
3980201	2 feet	110 - 155 CFM	115 volts, 50/60 Hz, 3 amps		115 volts, 15 amps	175 lbs. (79 kg)
3980203	2 feet	110 - 155 CFM	115 volts, 50/60 Hz, 3 amps	•	115 volts, 15 amps	175 lbs. (79 kg)
3980221†	2 feet	110 - 155 CFM	230 volts, 50/60 Hz, 2 amps		230 volts, 10 amps, no plug	175 lbs. (79 kg)
3980223†	2 feet	110 - 155 CFM	230 volts, 50/60 Hz, 2 amps	•	230 volts, 10 amps, no plug	175 lbs. (79 kg)
3980301	3 feet	165 - 230 CFM	115 volts, 50/60 Hz, 3 amps		115 volts, 15 amps	225 lbs. (102 kg)
3980303	3 feet	165 - 230 CFM	115 volts, 50/60 Hz, 3 amps	•	115 volts, 15 amps	225 lbs. (102 kg)
3980321†	3 feet	165 - 230 CFM	230 volts, 50/60 Hz, 2 amps		230 volts, 10 amps, no plug	225 lbs. (102 kg)
3980323†	3 feet	165 - 230 CFM	230 volts, 50/60 Hz, 2 amps	•	230 volts, 10 amps, no plug	225 lbs. (102 kg)
3980401	4 feet	220 - 310 CFM	115 volts, 50/60 Hz, 3 amps		115 volts, 15 amps	275 lbs. (125 kg)
3980403	4 feet	220 - 310 CFM	115 volts, 50/60 Hz, 3 amps	•	115 volts, 15 amps	275 lbs. (125 kg)
3980421†	4 feet	220 - 310 CFM	230 volts, 50/60 Hz, 2 amps		230 volts, 10 amps, no plug	275 lbs. (125 kg)
3980423†	4 feet	220 - 310 CFM	230 volts, 50/60 Hz, 2 amps	•	230 volts, 10 amps, no plug	275 lbs. (125 kg)

☒ Exclusive feature

\*U.S. Patent No. 6,461,233

†International electrical configuration

# PURIFIER® HEPA FILTERED ENCLOSURES

## ORDERING INFORMATION

### Standard Features

- Nominal inflow velocity of 75 to 105 fpm
- ☒ Ergonomic air foil with aerodynamic Clean-Sweep\* airflow openings
- ☒ Upper dilution air supply
- ☒ Zone-perforated rear baffle\*
- ☒ Side-entry air foils
  - Exhaust HEPA filter, 99.99% efficient on 0.3 micron particles
  - Variable speed built-in blower with dynamically-balanced, vibration-isolated motorized impeller and solid state control rated for 5 amps
- Intrinsically-safe, negative pressure design
- Differential pressure gauge
- Low discharge volume and quiet operation
- ☒ Upper containment sash foil
  - Glacier white and gray powder-coated aluminum frame and steel rear plenum and baffle
  - Fluorescent lamp
  - Switches for blower and light
  - 1/4" thick tempered safety glass front sash and sides
  - 9.44" high sash opening
  - Ergonomic 10° angled and hinged sash that pivots upward, locks to a loading height of 20" and has side wiping seals to contain contaminants
- Two utility ports with iris openings
- Particulate containment tested
- Biological containment verified per NSF Standard Number 49 Personnel Protection Test
- ASHRAE 110 conformity tested
- UL 61010-1 and CAN/CSA C22.2 conformity (115 volt models)
- CE Mark (230 volt models)
- One year warranty
- Validation package available



Purifier HEPA Filtered Safety Enclosure 3980402 on Solid Epoxy Dished Work Surface 3909902 and Telescoping Base Stand 3746702.

### Standard Option

- Guardian Airflow Monitor that continuously monitors airflow and has two LED lights to indicate when airflow is within or outside set point range.

### Required Accessories

- Supporting work surface. Place on existing casework or see page 6.
- Supporting base. Place on existing casework or see pages 28-31.

See page 6 for dimensional drawings.

Catalog #	Nominal Width	Exhaust Volume	Electrical Requirements	Airflow Monitor	Power Cord & Plug	Shipping Weight
3980200	2 feet	110 - 155 CFM	115 volts, 50/60 Hz, 3 amps		115 volts, 15 amps	175 lbs. (79 kg)
3980202	2 feet	110 - 155 CFM	115 volts, 50/60 Hz, 3 amps	•	115 volts, 15 amps	175 lbs. (79 kg)
3980220†	2 feet	110 - 155 CFM	230 volts, 50/60 Hz, 2 amps		230 volts, 10 amps, no plug	175 lbs. (79 kg)
3980222†	2 feet	110 - 155 CFM	230 volts, 50/60 Hz, 2 amps	•	230 volts, 10 amps, no plug	175 lbs. (79 kg)
3980300	3 feet	165 - 230 CFM	115 volts, 50/60 Hz, 3 amps		115 volts, 15 amps	225 lbs. (102 kg)
3980302	3 feet	165 - 230 CFM	115 volts, 50/60 Hz, 3 amps	•	115 volts, 15 amps	225 lbs. (102 kg)
3980320†	3 feet	165 - 230 CFM	230 volts, 50/60 Hz, 2 amps		230 volts, 10 amps, no plug	225 lbs. (102 kg)
3980322†	3 feet	165 - 230 CFM	230 volts, 50/60 Hz, 2 amps	•	230 volts, 10 amps, no plug	225 lbs. (102 kg)
3980400	4 feet	220 - 310 CFM	115 volts, 50/60 Hz, 3 amps		115 volts, 15 amps	275 lbs. (125 kg)
3980402	4 feet	220 - 310 CFM	115 volts, 50/60 Hz, 3 amps	•	115 volts, 15 amps	275 lbs. (125 kg)
3980420†	4 feet	220 - 310 CFM	230 volts, 50/60 Hz, 2 amps		230 volts, 10 amps, no plug	275 lbs. (125 kg)
3980422†	4 feet	220 - 310 CFM	230 volts, 50/60 Hz, 2 amps	•	230 volts, 10 amps, no plug	275 lbs. (125 kg)

☒ Exclusive feature

\* U.S. Patent No. 6,461,233

† International electrical configuration

# PURIFIER® CLASS I & HEPA FILTERED SAFETY ENCLOSURES

## D I M E N S I O N S & A C C E S S O R I E S

	2-Foot	3-Foot	4-Foot
A	24.0" (61.0 cm)	36.0" (91.4 cm)	48.0" (121.9 cm)
B	21.6" (54.9 cm)	33.6" (85.3 cm)	45.6" (115.8 cm)

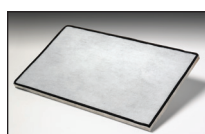
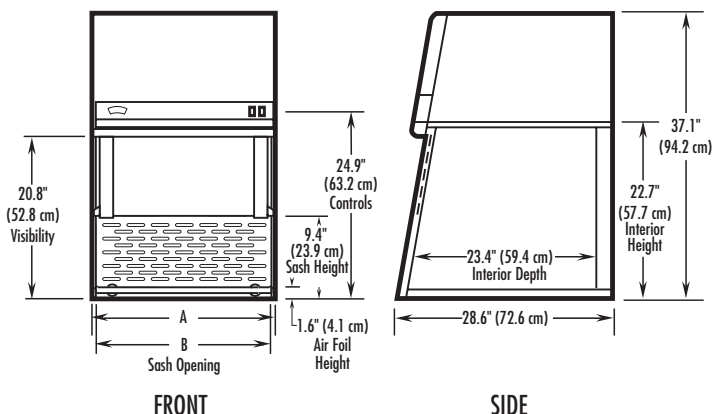

### Trace Odor Carbon Filters

For easy installation atop the Purifier Class I or HEPA Filtered Enclosure. Filters trap non-volatile nuisance odors and vapors from samples or minute quantities of chemicals.

Whether or not a Trace Odor Carbon Filter is appropriate for your application requires consideration of factors such as the time-weighted exposure limits of organic solvents, formaldehyde, ammonia or amines. Using Labconco's exclusive Chemical Assessment Program, our technical specialists can help you determine if the Purifier Enclosure with Trace Odor Carbon Filter is right for your applications and, if so, estimate filter life. To begin the process, please complete the Chemical Usage Assessment Form available at: [labconco.com](http://labconco.com) or call us at 800-821-5525 or 816-333-8811.

Catalog #	Description	For use with:	Shipping Weight
3937200	Organic, 5.5 lbs. activated carbon	2-Ft Purifier Enclosure	6.0 lbs. (2.7 kg)
3937300	Organic, 9.2 lbs. activated carbon	3-Ft Purifier Enclosure	10.0 lbs. (4.5 kg)
3937400	Organic, 12.9 lbs. activated carbon	4-Ft Purifier Enclosure	13.0 lbs. (5.9 kg)
3937201	Formaldehyde, 7 lbs. impregnated carbon	2-Ft Purifier Enclosure	7.5 lbs. (3.4 kg)
3937301	Formaldehyde, 12 lbs. impregnated carbon	3-Ft Purifier Enclosure	12.5 lbs. (5.7 kg)
3937401	Formaldehyde, 16.8 lbs. impregnated carbon	4-Ft Purifier Enclosure	17.0 lbs. (7.7 kg)
3937202	Ammonia & Amines, 8 lbs. impregnated carbon	2-Ft Purifier Enclosure	8.5 lbs. (3.9 kg)
3937302	Ammonia & Amines, 13.5 lbs. impregnated carbon	3-Ft Purifier Enclosure	14.0 lbs. (6.4 kg)
3937402	Ammonia & Amines, 18.9 lbs. impregnated carbon	4-Ft Purifier Enclosure	19.0 lbs. (8.6 kg)



### Solid Epoxy Dished Work Surfaces

Black chemical-resistant work surface is contoured to fit the dimensions of the Purifier Class I and HEPA Filtered Enclosure and to contain spills.

Catalog #	For use with	Dimensions	Shipping Weight
3909900	2-Ft Purifier Enclosure	24.0" w x 29.0" d x 1.0" h (61 cm x 73.7 cm x 2.5 cm)	50 lbs. (23 kg)
3909901	3-Ft Purifier Enclosure	36.0" w x 29.0" d x 1.0" h (91.4 cm x 73.7 cm x 2.5 cm)	75 lbs. (34 kg)
3909902	4-Ft Purifier Enclosure	48.0" w x 29.0" d x 1.0" h (122 cm x 73.7 cm x 2.5 cm)	100 lbs. (45 kg)

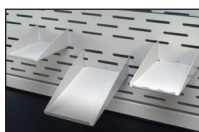

### 3925000 Utility Shelves

Three powder-coated steel shelves attach to the rear baffle perforations to hold a printer, utensils and other miscellaneous supplies. The utensil shelf has a scalloped front edge for spatulas, brushes and other items. Shipping weight 5.0 lbs. (2.2 kg)



### 3927700 Bottle Holder

Powder-coated steel. Attaches to the rear baffle perforations to hold a squirt bottle or other round container. 3" diameter opening. Shipping weight 1.0 lb. (0.5 kg)



### 3927800 Tissue Holder

Powder-coated steel. Attaches to the rear baffle perforations to hold a 4.63" x 4.75" box of tissue wipers in the upside down position. An opening in the bottom of the holder permits tissues to be dispensed from the bottom. Shipping weight 1 lb. (0.5 kg)



### 3744000 Ergonomic Chair with Armrests

Chair has 6-way articulating seat and back control. Pneumatic mechanism adjusts seat height from 18.25" to 25.75". Shipping weight 43.0 lbs. (19.5 kg). **⚠WARNING:** Cancer - P65Warnings.ca.gov (California only)



### 3746000 Adjustable Footrest

Elevates feet and permits angle repositioning while in use. 18.5" w x 11.5" d x 8" high. Shipping weight 6.0 lbs. (2.7 kg)

# PURIFIER® CLASS I & HEPA FILTERED SAFETY ENCLOSURES

## DUCTWORK & VENTILATION ACCESSORIES



### Remote Blowers

Coated steel blowers with belt-drive motors. Contact Labconco for information.

### Flexible Duct Connection

Reduces vibration between the blower and PVC ductwork. Supplied with two clamps. **WARNING:** Cancer - P65Warnings.ca.gov

Catalog #	Nominal Dia.	Shipping Wt.
4861800	7" for use with 6" fittings	8 lbs. (3.6 kg)

### Exhaust Dampers

Catalog #	Nominal Diameter	Material	Equivalent Resistance*	Shipping Weight
4724200	6"	PVC	1 ft.	1 lb. (0.5 kg)
3924000	6"	Powder-coated steel	1 ft.	1 lb. (0.5 kg)

### Duct Reducers

PVC reducers connect duct and male couplings of different diameters.

Catalog #	Nominal Dia.	Equivalent Resistance*	Shipping Wt.
5605900	6" x 8"	0	2 lbs. (0.9 kg)
5606000	8" x 10"	0	5 lbs. (2.3 kg)

### Coated-Coated Steel Blower Transition Adapter

Catalog #	Nominal Dia.	Equivalent Resistance*	Shipping Wt.
4722400	8"	1 ft.	3 lbs. (1.4 kg)

### Zero Pressure Weathercap

PVC Weathercap fits atop standard PVC duct, permits vertical discharge of effluent air above roof line for dispersion away from building.

Catalog #	Nominal Diameter	Equivalent Resistance*	Height	Shipping Weight
4722300	8"	5 ft.	40"	25 lbs. (11.3 kg)

### Canopy Connections

Connection allows the Enclosure to be canopy-ducted to the outside for additional protection. The canopy's air gap balances the air by allowing room air to enter the ductwork and mix with the filtered air being exhausted from the Enclosure. Outlet accepts 6" nominal diameter ductwork. **Ductwork and house exhaust or Remote Blower are required (not included).**

Catalog #	Description	For use with:	Exhaust Volume	Shipping Weight
3924400	2-Ft Canopy Connection	2-Ft Purifier Class I & HEPA Filtered Enclosures	110 to 155 CFM	15 lbs. (6.8 kg)
3924401	3-Ft Canopy Connection	3-Ft Purifier Class I & HEPA Filtered Enclosures	165 to 230 CFM	18 lbs. (8.2 kg)
3924402	4-Ft Canopy Connection	4-Ft Purifier Class I & HEPA Filtered Enclosures	220 to 310 CFM	21 lbs. (9.5 kg)

### Thermoplastic Duct

PVC exhaust duct in 10' lengths. A Female Duct Coupling and solvent cement are required to join two sections.

Catalog #	Nominal Dia.	Actual OD	Actual ID	Shipping Wt.
4708600	6"	6.625"	6.25"	25 lbs. (11.3 kg)
4718900	8"	8.625"	8.25"	35 lbs. (15.9 kg)

### Female Duct Coupling

PVC coupling joins two sections of Thermoplastic Duct.

Catalog #	Nominal Dia.	Equivalent Resistance*	Shipping Wt.
4708900	6"	0	4 lbs. (1.8 kg)

### Male Duct Coupling

PVC coupling joins two Duct Reducers and Duct Reducer to Blower.

Catalog #	Nominal Dia.	Equivalent Resistance*	Shipping Wt.
4719900	8"	0	4 lbs. (1.8 kg)
7027800	10"	0	5 lbs. (2.3 kg)

### 90° Elbow

PVC Elbow has belled end connections to receive Thermoplastic Duct or Male Duct Coupling directly.

Catalog #	Nominal Dia.	Equivalent Resistance*	Shipping Wt.
4708700	6"	12 ft.	8 lbs. (3.6 kg)

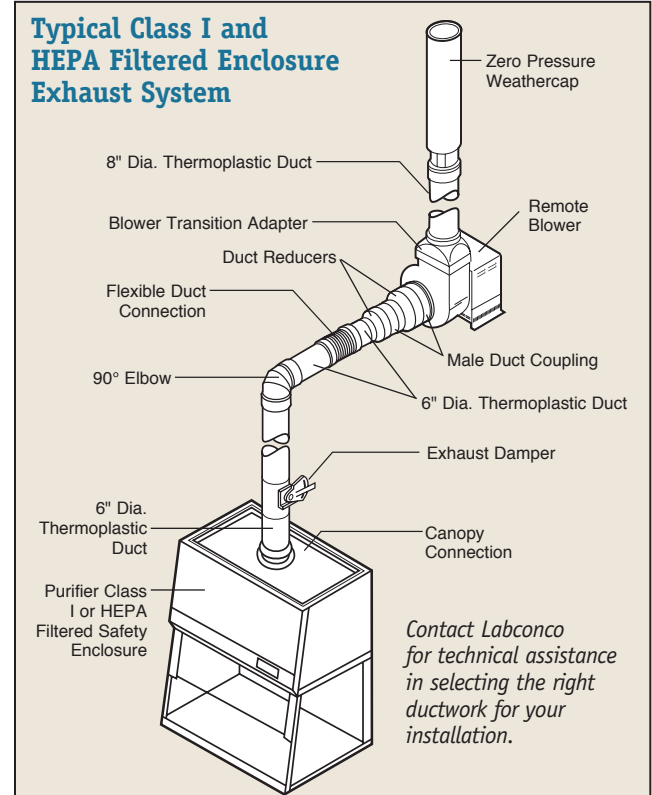

Contact Labconco for technical assistance in selecting the right ductwork for your installation.

\*Equivalent resistance is measured in feet of straight duct.

# PURIFIER® HORIZONTAL CLEAN BENCHES

## INTRODUCTION

**The Purifier Horizontal Clean Bench protects your work.** It is the ISO Class 5 work station of choice to protect materials that do not generate harmful aerosols or vapors, yet require a particulate-free environment. Suitable applications for the bench include plant tissue culture research, media preparation, electronic part inspection, syringe filling, medical device assembly and nonhazardous parenteral drug formulation.

Because air from the work area is dispersed directly into the laboratory, Purifier Horizontal Clean Benches should never be used in conjunction with biohazardous material, toxins or radionuclides. You and your safety officer must carefully assess the risk associated with any operation performed in a clean bench. Purifier Horizontal Clean Benches are offered in 3', 4', 5', 6' and 8' widths.



8' Purifier Horizontal Clean Bench 3818500 on Telescoping Base Stand 3857300, with Ergonomic Chair 3744000.

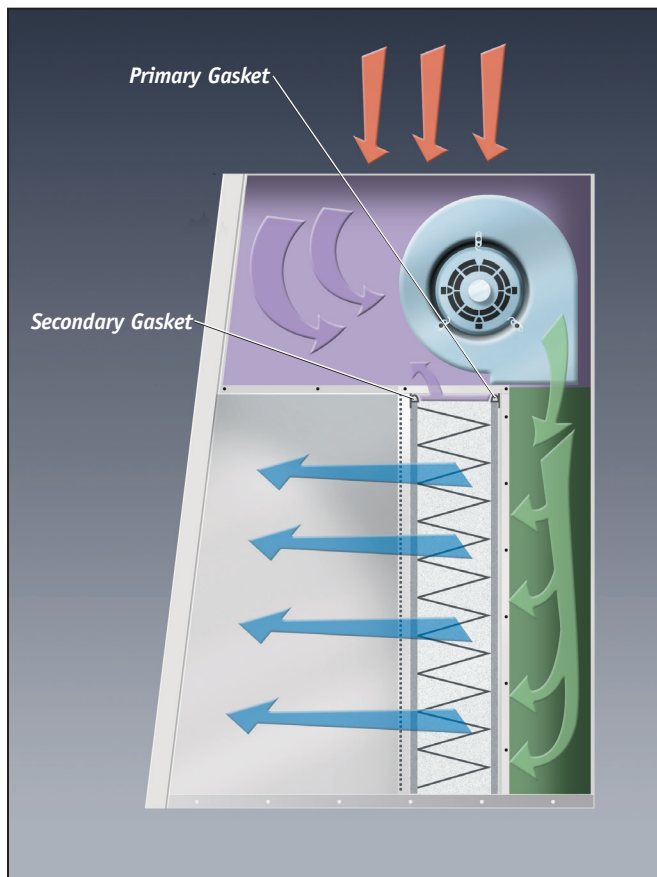

Room Air

HEPA-Filtered Air

Unfiltered Air under Negative Pressure

Unfiltered Air under Positive Pressure

During operation, room air is drawn through a prefilter in the top of the bench to trap large particles. Then, the air flows through a 99.99% efficient HEPA filter and is projected horizontally across the entire work area. This HEPA-filtered air minimizes cross contamination in the work area and provides a particulate-free work environment.

Unique to the Purifier Horizontal Clean Bench is its double HEPA filter seal. The primary gasket seals the upstream side of the filter to prevent unfiltered air from leaking into the work area. The secondary gasket at the front of the HEPA filter seals the downstream side of the filter frame. The area between these two gaskets is maintained under negative pressure. Should a leak occur at the primary HEPA filter gasket, the contaminated air is immediately recaptured and refiltered.



# PURIFIER® HORIZONTAL CLEAN BENCHES

## FEATURES & BENEFITS

**99.99% efficient HEPA filter** bathes the entire work area with ISO 5 air.

**Replaceable prefilters** trap large particles, extend HEPA filter life.

**Particle-free ISO Class 5 air.** Particle counts in the work area conform to ISO 14644-1 and 2, providing ISO Class 5 conditions. This ensures fewer than 3520 particles 0.5 µm or larger per cubic meter of air.

**Glare-free fluorescent lighting.**

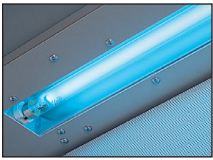

**Optional factory-installed 254 nm UV light with screen** for secondary decontamination while the bench is not in use. UV light switch is safety interlocked with the UV screen to help prevent inadvertent UV exposure while the bench is in operation.

**Variable digital timer** on models with optional UV light provides timed UV light exposure. From the front-mounted control panel, the operator may select from eight settings in minutes of 5, 10, 15, 30, 60, 120, 240 and continuous.



**Low vibration, variable speed motor/blower(s).**

**Differential pressure gauge** displays pressure across the HEPA filter.

**Angled profile design.** Front panel has no protrusions that could hinder visibility for taller users.

**Standard and Deep interior depths** of 21.0" (53.3 cm) and 26.0" (66.0 cm) provide flexibility and space for all applications.

**Front-mounted light and blower switches.**

**Double-gasket, negative pressure leak protection.**

**Two convenient utility ports with iris openings** allow passage of tubing and electrical cords from equipment inside the enclosure through the back for connection to services. Plugs are provided to seal the ports when not in use.

**Type 304 brushed stainless steel work surface** with comfortable rounded front edge.

**Accessory Telescoping Base Stand.** See pages 28-29 for ordering information.

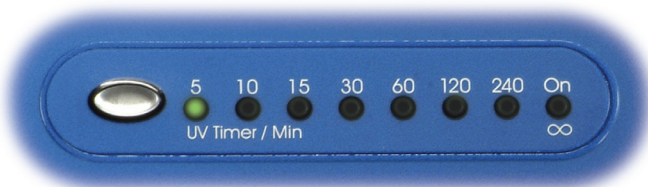

 Exclusive feature



# PURIFIER® HORIZONTAL CLEAN BENCHES

## ORDERING INFORMATION & DIMENSIONS



Purifier Horizontal Clean Bench 3818500 on Telescoping Base Stand 3857300

### Standard Features

- Horizontal unidirectional flow
- 99.99% efficient HEPA filter (2 each on 8' models)
- Prefilters (2 each on 3' and 4' models; 3 each on 5' and 6' models; 4 each on 8' models)
- ISO 5 air per ISO 14644-1 and 2
- Differential pressure gauge
- Double-gasket, negative pressure HEPA filter leak protection
- Front-mounted light and blower switches
- Variable speed motor/blower(s) with vibration isolation pad (2 each on 5', 6' and 8' models)
- Fluorescent lighting
- Type 304 brushed stainless steel work surface
- Glacier white powder-coated steel exterior
- 1/4" thick tempered safety glass side panels with utility ports with iris openings
- May be disassembled for passage through a narrow door or hallway (16.4" deep passageway minimum)
- Angled front profile
- 10' (3 m) power cord with plug
- UL 61010-1 and CAN/CSA C22.2 conformity (115 volt models)
- CE Mark (230 volt models)
- One year warranty

 Exclusive feature

### Standard Option Package

- Factory-installed, 254 nm UV lamp with UV screen and interlocking safety switch allowing operation only when blower and fluorescent light are off, and UV screen is closed

### Required Accessory

- Supporting base. Place on existing casework or see pages 28-29.

# 3-FT & 4-FT PURIFIER® HORIZONTAL CLEAN BENCHES

## ORDERING INFORMATION

Catalog #	Nominal Width	Interior Depth	Electrical Requirements	Plug Type	Light(s)	Shipping Weight
<b>3889700</b>	3 feet	21.0" (53 cm)	115 volts, 60 Hz, 6 amps	115 volts, 15 amps	Fluorescent	364 lbs. (165 kg)
<b>3889701</b>	3 feet	26.0" (66 cm)	115 volts, 60 Hz, 6 amps	115 volts, 15 amps	Fluorescent	372 lbs. (169 kg)
<b>3889702</b>	3 feet	21.0" (53 cm)	230 volts, 50/60 Hz, 3 amps	N. America, 230 volts	Fluorescent	364 lbs. (165 kg)
<b>3889703</b>	3 feet	26.0" (66 cm)	230 volts, 50/60 Hz, 3 amps	N. America, 230 volts	Fluorescent	372 lbs. (169 kg)
<b>3889705*</b>	3 feet	21.0" (53 cm)	230 volts, 50/60 Hz, 3 amps	British (UK)	Fluorescent	364 lbs. (165 kg)
<b>3889706*</b>	3 feet	26.0" (66 cm)	230 volts, 50/60 Hz, 3 amps	British (UK)	Fluorescent	372 lbs. (169 kg)
<b>3889708*</b>	3 feet	21.0" (53 cm)	230 volts, 50/60 Hz, 3 amps	Schuko	Fluorescent	364 lbs. (165 kg)
<b>3889709*</b>	3 feet	26.0" (66 cm)	230 volts, 50/60 Hz, 3 amps	Schuko	Fluorescent	372 lbs. (169 kg)
<b>3889711*</b>	3 feet	21.0" (53 cm)	230 volts, 50/60 Hz, 3 amps	China/Australia	Fluorescent	364 lbs. (165 kg)
<b>3889712*</b>	3 feet	26.0" (66 cm)	230 volts, 50/60 Hz, 3 amps	China/Australia	Fluorescent	372 lbs. (169 kg)
<b>3889720</b>	3 feet	21.0" (53 cm)	115 volts, 60 Hz, 6 amps	115 volts, 15 amps	Fluorescent/UV	364 lbs. (165 kg)
<b>3889721</b>	3 feet	26.0" (66 cm)	115 volts, 60 Hz, 6 amps	115 volts, 15 amps	Fluorescent/UV	372 lbs. (169 kg)
<b>3889722</b>	3 feet	21.0" (53 cm)	230 volts, 50/60 Hz, 3 amps	N. America, 230 volts	Fluorescent/UV	364 lbs. (165 kg)
<b>3889723</b>	3 feet	26.0" (66 cm)	230 volts, 50/60 Hz, 3 amps	N. America, 230 volts	Fluorescent/UV	372 lbs. (169 kg)
<b>3889725*</b>	3 feet	21.0" (53 cm)	230 volts, 50/60 Hz, 3 amps	British (UK)	Fluorescent/UV	364 lbs. (165 kg)
<b>3889726*</b>	3 feet	26.0" (66 cm)	230 volts, 50/60 Hz, 3 amps	British (UK)	Fluorescent/UV	372 lbs. (169 kg)
<b>3889728*</b>	3 feet	21.0" (53 cm)	230 volts, 50/60 Hz, 3 amps	Schuko	Fluorescent/UV	364 lbs. (165 kg)
<b>3889729*</b>	3 feet	26.0" (66 cm)	230 volts, 50/60 Hz, 3 amps	Schuko	Fluorescent/UV	372 lbs. (169 kg)
<b>3889731*</b>	3 feet	21.0" (53 cm)	230 volts, 50/60 Hz, 3 amps	China/Australia	Fluorescent/UV	364 lbs. (165 kg)
<b>3889732*</b>	3 feet	26.0" (66 cm)	230 volts, 50/60 Hz, 3 amps	China/Australia	Fluorescent/UV	372 lbs. (169 kg)
<b>3888400</b>	4 feet	21.0" (53 cm)	115 volts, 60 Hz, 6 amps	115 volts, 15 amps	Fluorescent	455 lbs. (206 kg)
<b>3888401</b>	4 feet	26.0" (66 cm)	115 volts, 60 Hz, 6 amps	115 volts, 15 amps	Fluorescent	465 lbs. (211 kg)
<b>3888402</b>	4 feet	21.0" (53 cm)	230 volts, 50/60 Hz, 3 amps	N. America, 230 volts	Fluorescent	455 lbs. (206 kg)
<b>3888403</b>	4 feet	26.0" (66 cm)	230 volts, 50/60 Hz, 3 amps	N. America, 230 volts	Fluorescent	465 lbs. (211 kg)
<b>3888405*</b>	4 feet	21.0" (53 cm)	230 volts, 50/60 Hz, 3 amps	British (UK)	Fluorescent	455 lbs. (206 kg)
<b>3888406*</b>	4 feet	26.0" (66 cm)	230 volts, 50/60 Hz, 3 amps	British (UK)	Fluorescent	465 lbs. (211 kg)
<b>3888408*</b>	4 feet	21.0" (53 cm)	230 volts, 50/60 Hz, 3 amps	Schuko	Fluorescent	455 lbs. (206 kg)
<b>3888409*</b>	4 feet	26.0" (66 cm)	230 volts, 50/60 Hz, 3 amps	Schuko	Fluorescent	465 lbs. (211 kg)
<b>3888411*</b>	4 feet	21.0" (53 cm)	230 volts, 50/60 Hz, 3 amps	China/Australia	Fluorescent	455 lbs. (206 kg)
<b>3888412*</b>	4 feet	26.0" (66 cm)	230 volts, 50/60 Hz, 3 amps	China/Australia	Fluorescent	465 lbs. (211 kg)
<b>3888420</b>	4 feet	21.0" (53 cm)	115 volts, 60 Hz, 6 amps	115 volts, 15 amps	Fluorescent/UV	455 lbs. (206 kg)
<b>3888421</b>	4 feet	26.0" (66 cm)	115 volts, 60 Hz, 6 amps	115 volts, 15 amps	Fluorescent/UV	465 lbs. (211 kg)
<b>3888422</b>	4 feet	21.0" (53 cm)	230 volts, 50/60 Hz, 3 amps	N. America, 230 volts	Fluorescent/UV	455 lbs. (206 kg)
<b>3888423</b>	4 feet	26.0" (66 cm)	230 volts, 50/60 Hz, 3 amps	N. America, 230 volts	Fluorescent/UV	465 lbs. (211 kg)
<b>3888425*</b>	4 feet	21.0" (53 cm)	230 volts, 50/60 Hz, 3 amps	British (UK)	Fluorescent/UV	455 lbs. (206 kg)
<b>3888426*</b>	4 feet	26.0" (66 cm)	230 volts, 50/60 Hz, 3 amps	British (UK)	Fluorescent/UV	465 lbs. (211 kg)
<b>3888428*</b>	4 feet	21.0" (53 cm)	230 volts, 50/60 Hz, 3 amps	Schuko	Fluorescent/UV	455 lbs. (206 kg)
<b>3888429*</b>	4 feet	26.0" (66 cm)	230 volts, 50/60 Hz, 3 amps	Schuko	Fluorescent/UV	465 lbs. (211 kg)
<b>3888431*</b>	4 feet	21.0" (53 cm)	230 volts, 50/60 Hz, 3 amps	China/Australia	Fluorescent/UV	455 lbs. (206 kg)
<b>3888432*</b>	4 feet	26.0" (66 cm)	230 volts, 50/60 Hz, 3 amps	China/Australia	Fluorescent/UV	465 lbs. (211 kg)

\*International electrical configuration

### Plug Types

115 V, 15 A



For Catalog Numbers  
**3889700, 3889701,**  
**3889720, 3889721,**  
**3888400, 3888401,**  
**3888420, 3888421**

N. America, 230 V



For Catalog Numbers  
**3889702, 3889703,**  
**3889722, 3889723,**  
**3888402, 3888403,**  
**3888422, 3888423**

British (UK)

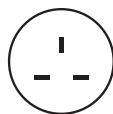

For Catalog Numbers  
**3889705, 3889706,**  
**3889725, 3889726,**  
**3888405, 3888406,**  
**3888425, 3888426**

Schuko

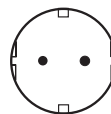

For Catalog Numbers  
**3889708, 3889709,**  
**3889728, 3889729,**  
**3888408, 3888409,**  
**3888428, 3888429**

China/Australia



For Catalog Numbers  
**3889711, 3889712,**  
**3889731, 3889732,**  
**3888411, 3888412,**  
**3888431, 3888432**

# 5-FT PURIFIER® HORIZONTAL CLEAN BENCHES

## ORDERING INFORMATION

Catalog #	Nominal Width	Interior Depth	Electrical Requirements	Plug Type	Light(s)	Shipping Weight
<b>3250000</b>	5 feet	21.0" (53 cm)	115 volts, 60 Hz, 6 amps	115 volts, 15 amps	Fluorescent	560 lbs. (254 kg)
<b>3250001</b>	5 feet	26.0" (66 cm)	115 volts, 60 Hz, 6 amps	115 volts, 15 amps	Fluorescent	575 lbs. (261 kg)
<b>3250002</b>	5 feet	21.0" (53 cm)	230 volts, 50/60 Hz, 3 amps	N. America, 230 volts	Fluorescent	560 lbs. (254 kg)
<b>3250003</b>	5 feet	26.0" (66 cm)	230 volts, 50/60 Hz, 3 amps	N. America, 230 volts	Fluorescent	575 lbs. (261 kg)
<b>3250005*</b>	5 feet	21.0" (53 cm)	230 volts, 50/60 Hz, 3 amps	British (UK)	Fluorescent	560 lbs. (254 kg)
<b>3250006*</b>	5 feet	26.0" (66 cm)	230 volts, 50/60 Hz, 3 amps	British (UK)	Fluorescent	575 lbs. (261 kg)
<b>3250008*</b>	5 feet	21.0" (53 cm)	230 volts, 50/60 Hz, 3 amps	Schuko	Fluorescent	560 lbs. (254 kg)
<b>3250009*</b>	5 feet	26.0" (66 cm)	230 volts, 50/60 Hz, 3 amps	Schuko	Fluorescent	575 lbs. (261 kg)
<b>3250011*</b>	5 feet	21.0" (53 cm)	230 volts, 50/60 Hz, 3 amps	China/Australia	Fluorescent	560 lbs. (254 kg)
<b>3250012*</b>	5 feet	26.0" (66 cm)	230 volts, 50/60 Hz, 3 amps	China/Australia	Fluorescent	575 lbs. (261 kg)
<b>3250020</b>	5 feet	21.0" (53 cm)	115 volts, 60 Hz, 6 amps	115 volts, 15 amps	Fluorescent/UV	560 lbs. (254 kg)
<b>3250021</b>	5 feet	26.0" (66 cm)	115 volts, 60 Hz, 6 amps	115 volts, 15 amps	Fluorescent/UV	575 lbs. (261 kg)
<b>3250022</b>	5 feet	21.0" (53 cm)	230 volts, 50/60 Hz, 3 amps	N. America, 230 volts	Fluorescent/UV	560 lbs. (254 kg)
<b>3250023</b>	5 feet	26.0" (66 cm)	230 volts, 50/60 Hz, 3 amps	N. America, 230 volts	Fluorescent/UV	575 lbs. (261 kg)
<b>3250025*</b>	5 feet	21.0" (53 cm)	230 volts, 50/60 Hz, 3 amps	British (UK)	Fluorescent/UV	560 lbs. (254 kg)
<b>3250026*</b>	5 feet	26.0" (66 cm)	230 volts, 50/60 Hz, 3 amps	British (UK)	Fluorescent/UV	575 lbs. (261 kg)
<b>3250028*</b>	5 feet	21.0" (53 cm)	230 volts, 50/60 Hz, 3 amps	Schuko	Fluorescent/UV	560 lbs. (254 kg)
<b>3250029*</b>	5 feet	26.0" (66 cm)	230 volts, 50/60 Hz, 3 amps	Schuko	Fluorescent/UV	575 lbs. (261 kg)
<b>3250031*</b>	5 feet	21.0" (53 cm)	230 volts, 50/60 Hz, 3 amps	China/Australia	Fluorescent/UV	560 lbs. (254 kg)
<b>3250032*</b>	5 feet	26.0" (66 cm)	230 volts, 50/60 Hz, 3 amps	China/Australia	Fluorescent/UV	575 lbs. (261 kg)

\*International electrical configuration

### Plug Types

115 V, 15 A



For Catalog Numbers  
3250000, 3250001,  
3250020, 3250021

N. America, 230 V



For Catalog Numbers  
3250002, 3250003,  
3250022, 3250023

British (UK)

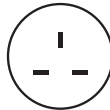

For Catalog Numbers  
3250005, 3250006,  
3250025, 3250026

Schuko

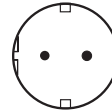

For Catalog Numbers  
3250008, 3250009,  
3250028, 3250029

China/Australia



For Catalog Numbers  
3250011, 3250012,  
3250031, 3250032

# 6-FT & 8-FT PURIFIER® HORIZONTAL CLEAN BENCHES

## ORDERING INFORMATION

Catalog #	Nominal Width	Interior Depth	Electrical Requirements	Plug Type	Light(s)	Shipping Weight
<b>3873000</b>	6 feet	21.0" (53 cm)	115 volts, 60 Hz, 6 amps	115 volts, 15 amps	Fluorescent	645 lbs. (293 kg)
<b>3873001</b>	6 feet	26.0" (66 cm)	115 volts, 60 Hz, 6 amps	115 volts, 15 amps	Fluorescent	660 lbs. (299 kg)
<b>3873002</b>	6 feet	21.0" (53 cm)	230 volts, 50/60 Hz, 3 amps	N. America, 230 volts	Fluorescent	645 lbs. (293 kg)
<b>3873003</b>	6 feet	26.0" (66 cm)	230 volts, 50/60 Hz, 3 amps	N. America, 230 volts	Fluorescent	660 lbs. (299 kg)
<b>3873005*</b>	6 feet	21.0" (53 cm)	230 volts, 50/60 Hz, 3 amps	British (UK)	Fluorescent	645 lbs. (293 kg)
<b>3873006*</b>	6 feet	26.0" (66 cm)	230 volts, 50/60 Hz, 3 amps	British (UK)	Fluorescent	660 lbs. (299 kg)
<b>3873008*</b>	6 feet	21.0" (53 cm)	230 volts, 50/60 Hz, 3 amps	Schuko	Fluorescent	645 lbs. (293 kg)
<b>3873009*</b>	6 feet	26.0" (66 cm)	230 volts, 50/60 Hz, 3 amps	Schuko	Fluorescent	660 lbs. (299 kg)
<b>3873011*</b>	6 feet	21.0" (53 cm)	230 volts, 50/60 Hz, 3 amps	China/Australia	Fluorescent	645 lbs. (293 kg)
<b>3873012*</b>	6 feet	26.0" (66 cm)	230 volts, 50/60 Hz, 3 amps	China/Australia	Fluorescent	660 lbs. (299 kg)
<b>3873020</b>	6 feet	21.0" (53 cm)	115 volts, 60 Hz, 6 amps	115 volts, 15 amps	Fluorescent/UV	645 lbs. (293 kg)
<b>3873021</b>	6 feet	26.0" (66 cm)	115 volts, 60 Hz, 6 amps	115 volts, 15 amps	Fluorescent/UV	660 lbs. (299 kg)
<b>3873022</b>	6 feet	21.0" (53 cm)	230 volts, 50/60 Hz, 3 amps	N. America, 230 volts	Fluorescent/UV	645 lbs. (293 kg)
<b>3873023</b>	6 feet	26.0" (66 cm)	230 volts, 50/60 Hz, 3 amps	N. America, 230 volts	Fluorescent/UV	660 lbs. (299 kg)
<b>3873025*</b>	6 feet	21.0" (53 cm)	230 volts, 50/60 Hz, 3 amps	British (UK)	Fluorescent/UV	645 lbs. (293 kg)
<b>3873026*</b>	6 feet	26.0" (66 cm)	230 volts, 50/60 Hz, 3 amps	British (UK)	Fluorescent/UV	660 lbs. (299 kg)
<b>3873028*</b>	6 feet	21.0" (53 cm)	230 volts, 50/60 Hz, 3 amps	Schuko	Fluorescent/UV	645 lbs. (293 kg)
<b>3873029*</b>	6 feet	26.0" (66 cm)	230 volts, 50/60 Hz, 3 amps	Schuko	Fluorescent/UV	660 lbs. (299 kg)
<b>3873031*</b>	6 feet	21.0" (53 cm)	230 volts, 50/60 Hz, 3 amps	China/Australia	Fluorescent/UV	645 lbs. (293 kg)
<b>3873032*</b>	6 feet	26.0" (66 cm)	230 volts, 50/60 Hz, 3 amps	China/Australia	Fluorescent/UV	660 lbs. (299 kg)
<b>3818500</b>	8 feet	21.0" (53 cm)	115 volts, 60 Hz, 6 amps	115 volts, 20 amps	Fluorescent	835 lbs. (379 kg)
<b>3818501</b>	8 feet	26.0" (66 cm)	115 volts, 60 Hz, 6 amps	115 volts, 20 amps	Fluorescent	855 lbs. (388 kg)
<b>3818502</b>	8 feet	21.0" (53 cm)	230 volts, 50/60 Hz, 3 amps	N. America, 230 volts	Fluorescent	835 lbs. (379 kg)
<b>3818503</b>	8 feet	26.0" (66 cm)	230 volts, 50/60 Hz, 3 amps	N. America, 230 volts	Fluorescent	855 lbs. (388 kg)
<b>3818505*</b>	8 feet	21.0" (53 cm)	230 volts, 50/60 Hz, 3 amps	British (UK)	Fluorescent	835 lbs. (379 kg)
<b>3818506*</b>	8 feet	26.0" (66 cm)	230 volts, 50/60 Hz, 3 amps	British (UK)	Fluorescent	855 lbs. (388 kg)
<b>3818508*</b>	8 feet	21.0" (53 cm)	230 volts, 50/60 Hz, 3 amps	Schuko	Fluorescent	835 lbs. (379 kg)
<b>3818509*</b>	8 feet	26.0" (66 cm)	230 volts, 50/60 Hz, 3 amps	Schuko	Fluorescent	855 lbs. (388 kg)
<b>3818511*</b>	8 feet	21.0" (53 cm)	230 volts, 50/60 Hz, 3 amps	China/Australia	Fluorescent	835 lbs. (379 kg)
<b>3818512*</b>	8 feet	26.0" (66 cm)	230 volts, 50/60 Hz, 3 amps	China/Australia	Fluorescent	855 lbs. (388 kg)
<b>3818520</b>	8 feet	21.0" (53 cm)	115 volts, 60 Hz, 6 amps	115 volts, 20 amps	Fluorescent/UV	835 lbs. (379 kg)
<b>3818521</b>	8 feet	26.0" (66 cm)	115 volts, 60 Hz, 6 amps	115 volts, 20 amps	Fluorescent/UV	855 lbs. (388 kg)
<b>3818522</b>	8 feet	21.0" (53 cm)	230 volts, 50/60 Hz, 3 amps	N. America, 230 volts	Fluorescent/UV	835 lbs. (379 kg)
<b>3818523</b>	8 feet	26.0" (66 cm)	230 volts, 50/60 Hz, 3 amps	N. America, 230 volts	Fluorescent/UV	855 lbs. (388 kg)
<b>3818525*</b>	8 feet	21.0" (53 cm)	230 volts, 50/60 Hz, 3 amps	British (UK)	Fluorescent/UV	835 lbs. (379 kg)
<b>3818526*</b>	8 feet	26.0" (66 cm)	230 volts, 50/60 Hz, 3 amps	British (UK)	Fluorescent/UV	855 lbs. (388 kg)
<b>3818528*</b>	8 feet	21.0" (53 cm)	230 volts, 50/60 Hz, 3 amps	Schuko	Fluorescent/UV	835 lbs. (379 kg)
<b>3818529*</b>	8 feet	26.0" (66 cm)	230 volts, 50/60 Hz, 3 amps	Schuko	Fluorescent/UV	855 lbs. (388 kg)
<b>3818531*</b>	8 feet	21.0" (53 cm)	230 volts, 50/60 Hz, 3 amps	China/Australia	Fluorescent/UV	835 lbs. (379 kg)
<b>3818532*</b>	8 feet	26.0" (66 cm)	230 volts, 50/60 Hz, 3 amps	China/Australia	Fluorescent/UV	855 lbs. (388 kg)

\*International electrical configuration

### Plug Types

115 V, 15 A



For Catalog Numbers  
3873000, 3873001,  
3873020, 3873021

115 V, 20 A

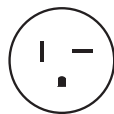

For Catalog Numbers  
3818500, 3818501,  
3818520, 3818521

N. America, 230 V



For Catalog Numbers  
3873002, 3873003,  
3873022, 3873023,  
3818502, 3818503,  
3818522, 3818523

British (UK)

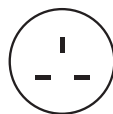

For Catalog Numbers  
3873005, 3873006,  
3873025, 3873026,  
3818505, 3818506,  
3818525, 3818526

Schuko

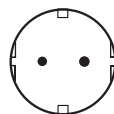

For Catalog Numbers  
3873008, 3873009,  
3873028, 3873029,  
3818508, 3818509,  
3818528, 3818529

China/Australia



For Catalog Numbers  
3873011, 3873012,  
3873031, 3873032,  
3818511, 3818512,  
3818531, 3818532

# PURIFIER® HORIZONTAL CLEAN BENCHES

## D I M E N S I O N S

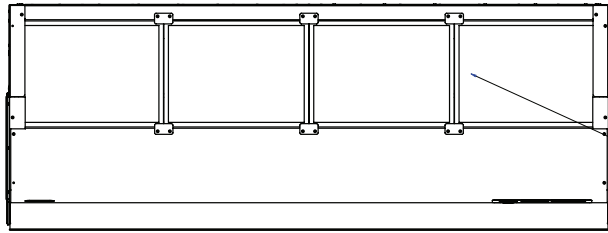

TOP VIEW

2 PREFILTERS on 3-ft & 4-ft models  
3 PREFILTERS on 5-ft & 6-ft models  
4 PREFILTERS on 8-ft models

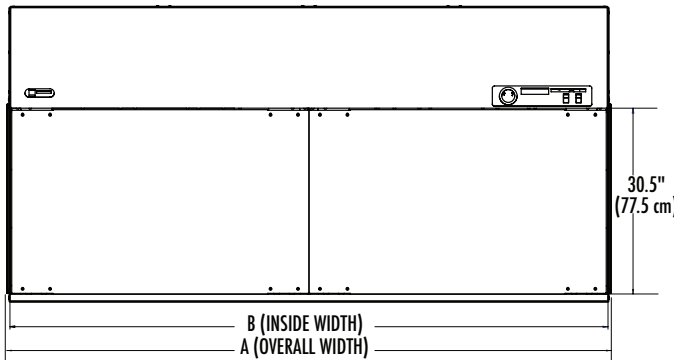

FRONT VIEW

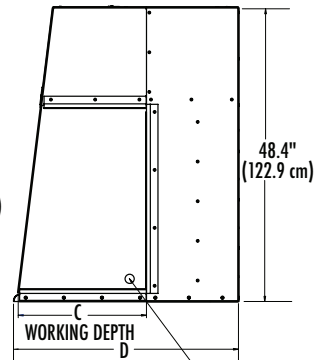

SIDE VIEW

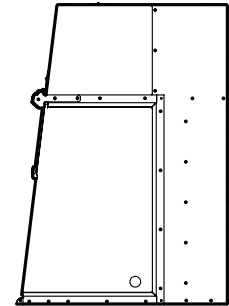

SIDE VIEW UV SCREEN DETAIL

Catalog #	A	B	C	D
3889700, 3889702, 3889705, 3889708, 3889711	38.0" (96.5 cm)	37.0" (94.0 cm)	21.0" (53.3 cm)	34.0" (86.4 cm)
3889720, 3889722, 3889725, 3889728, 3889731	39.0" (99.1 cm)	37.0" (94.0 cm)	21.0" (53.3 cm)	34.0" (86.4 cm)
3889701, 3889703, 3889706, 3889709, 3889712	38.0" (96.5 cm)	37.0" (94.0 cm)	26.0" (66.0 cm)	39.0" (99.1 cm)
3889721, 3889723, 3889726, 3889729, 3889732	39.0" (99.1 cm)	37.0" (94.0 cm)	26.0" (66.0 cm)	39.0" (99.1 cm)
3888400, 3888402, 3888405, 3888408, 3888411	50.0" (127.0 cm)	49.0" (124.5 cm)	21.0" (53.3 cm)	34.0" (86.4 cm)
3888420, 3888422, 3888425, 3888428, 3888431	51.0" (129.5 cm)	49.0" (124.5 cm)	21.0" (53.3 cm)	34.0" (86.4 cm)
3888401, 3888403, 3888406, 3888409, 3888412	50.0" (127.0 cm)	49.0" (124.5 cm)	26.0" (66.0 cm)	39.0" (99.1 cm)
3888421, 3888423, 3888426, 3888429, 3888432	51.0" (127.0 cm)	49.0" (124.5 cm)	26.0" (66.0 cm)	39.0" (99.1 cm)
3250000, 3250002, 3250005, 3250008, 3250011	62.0" (157.5 cm)	61.0" (154.9 cm)	21.0" (53.3 cm)	34.0" (86.4 cm)
3250020, 3250022, 3250025, 3250028, 3250031	63.0" (160.0 cm)	61.0" (154.9 cm)	21.0" (53.3 cm)	34.0" (86.4 cm)
3250001, 3250003, 3250006, 3250009, 3250012	62.0" (157.5 cm)	61.0" (154.9 cm)	26.0" (66.0 cm)	39.0" (99.1 cm)
3250021, 3250023, 3250026, 3250029, 3250032	63.0" (160.0 cm)	61.0" (154.9 cm)	26.0" (66.0 cm)	39.0" (99.1 cm)
3873000, 3873002, 3873005, 3873008, 3873011	74.0" (188.0 cm)	73.0" (182.5 cm)	21.0" (53.3 cm)	34.0" (86.4 cm)
3873020, 3873022, 3873025, 3873028, 3873031	75.0" (190.5 cm)	73.0" (182.5 cm)	21.0" (53.3 cm)	34.0" (86.4 cm)
3873001, 3873003, 3873006, 3873009, 3873012	74.0" (188.0 cm)	73.0" (182.5 cm)	26.0" (66.0 cm)	39.0" (99.1 cm)
3873021, 3873023, 3873026, 3873029, 3873032	75.0" (190.5 cm)	73.0" (182.5 cm)	26.0" (66.0 cm)	39.0" (99.1 cm)
3818500, 3818502, 3818505, 3818508, 3818511	99.0" (251.5 cm)	98.0" (248.9 cm)	21.0" (53.3 cm)	34.0" (86.4 cm)
3818520, 3818522, 3818525, 3818528, 3818531	100.0" (254.0 cm)	98.0" (248.9 cm)	21.0" (53.3 cm)	34.0" (86.4 cm)
3818501, 3818503, 3818506, 3818509, 3818512	99.0" (251.5 cm)	98.0" (248.9 cm)	26.0" (66.0 cm)	39.0" (99.1 cm)
3818521, 3818523, 3818526, 3818529, 3818532	100.0" (254.0 cm)	98.0" (248.9 cm)	26.0" (66.0 cm)	39.0" (99.1 cm)

# PURIFIER® HORIZONTAL CLEAN BENCHES

## ACCESSORIES



### Base Stands

Powder-coated steel frame. Available in Telescoping, Manual Hydraulic and Electric Hydraulic Configurations.

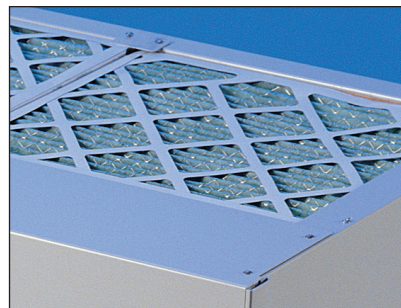

### Replacement Prefilters

Labconco recommends replacing prefilters every three months. One each. Shipping weight 1.0 lb. (0.4 kg)

Catalog #	For use with:	# Required
3768900	3-Ft Purifier Clean Benches	2
3768901	4-Ft Purifier Clean Benches	2
3768900	5-Ft Purifier Clean Benches	2
3768901	5-Ft Purifier Clean Benches	1
3768901	6-Ft Purifier Clean Benches	3
3768901	8-Ft Purifier Clean Benches	4



### IV Bar Kits

Support intravenous solution bottles and bags. Each includes IV bar, mounting hardware, four hangers and instructions for installation. Three-foot, four-foot and five-foot Purifier Clean Benches accommodate one IV bar. Six-foot and eight-foot benches accommodate two. Shipping weight 5.0 lbs. (2.3 kg)

Catalog #	For use with:	# Required
3697500	3-Ft Purifier Clean Benches	1
3697500	4-Ft Purifier Clean Benches	1
3697501	5-Ft Purifier Clean Benches	1
3697500	6-Ft Purifier Clean Benches	2
3697500	8-Ft Purifier Clean Benches	2



### 3744000 Ergonomic Chair with Armrests

Lab chair has 6-way articulating seat and back control. Pneumatic mechanism adjusts seat height from 18.25" to 25.75". Shipping weight 43.0 lbs. (19.5 kg).  
**⚠WARNING:** Cancer - P65Warnings.ca.gov (California only)



### 3746000 Adjustable Footrest

Elevates feet and permits angle repositioning while in use. 18.5" w x 11.5" d x 8" high. Shipping weight 6.0 lbs. (2.7 kg)

# PURIFIER® VERTICAL CLEAN BENCHES

## INTRODUCTION

**Purifier Vertical Clean Benches protect your work from particulate contamination.** Using a 99.99% efficient supply HEPA filter, Purifier Vertical Clean Benches maintain ISO Class 5 conditions in the work area. Appropriate applications for Clean Benches include plant tissue culture, media plate preparation, electronics inspection, medical device assembly and IV drug compounding.

Because Purifier Vertical Clean Benches do not provide protection to the user, they should not be used in conjunction with biohazardous material, toxins or radionuclides. You and your safety officer must carefully assess the risk associated with any operation performed in a clean bench.

Purifier Vertical Clean Benches are offered in 2', 3', 4', and 6' widths. Built-in options include a UV light with timer for secondary decontamination and a Guardian Airflow Monitor to monitor downflow velocity and HEPA filter loading.



*Purifier Vertical Clean Bench 3970200 on Solid Epoxy Dished Work Surface 3909900 and Telescoping Base Stand 3746710 with Ergonomic Chair 3744000 and Adjustable Footrest 3746000.*

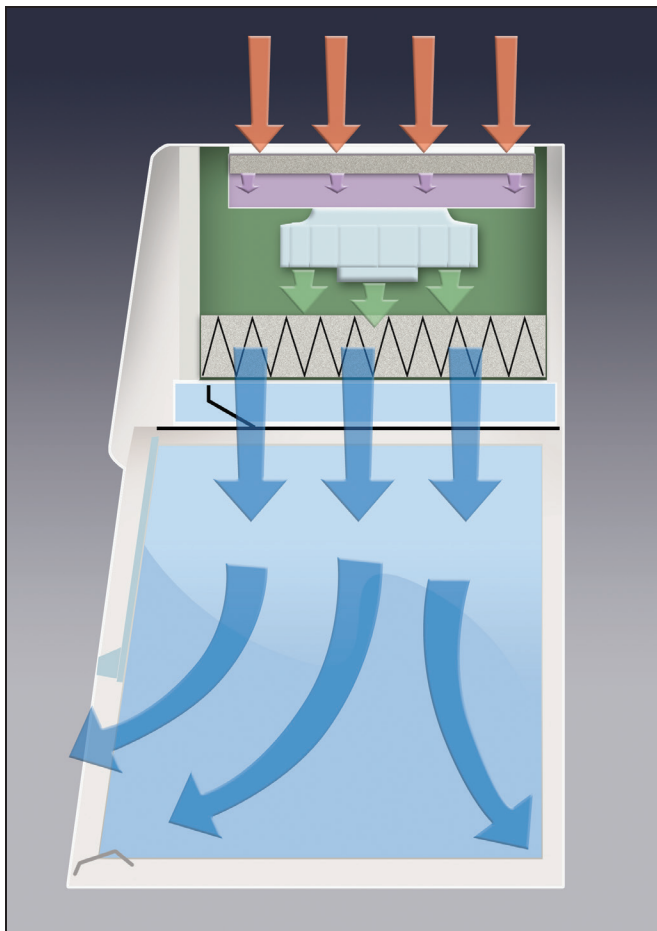

*During operation, room air is drawn through a prefilter in the top of the cabinet to trap large particles. Then, the air flows through a 99.99% efficient HEPA filter and is projected vertically over the work area. This HEPA-filtered air prevents contaminants from entering the work area and provides a particulate-free work environment that minimizes cross contamination.*

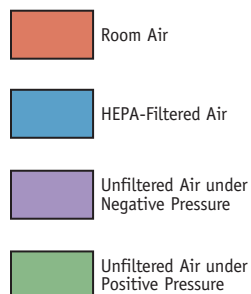



# PURIFIER® VERTICAL CLEAN BENCHES

## FEATURES & BENEFITS

**HEPA filter** is rated to remove 99.99% of all particles 0.3 microns in size.

**Particulate-free ISO Class 5 air.** Particle counts in the work area conform to ISO 14644-1 and 2, providing ISO Class 5 conditions

**Front-mounted differential pressure gauge** indicates the total system pressure across the HEPA filter and pressurized plenum to help determine HEPA filter loading.

**Variable digital timer** provides timed UV light exposure on models with UV lamp. From the front-mounted control panel, the operator may select from eight settings in minutes of 5, 10, 15, 30, 60, 120, 240 and continuous.

**Disposable prefilter** traps large particles to extend the life of the HEPA filter.

**Support hooks** (on models with UV lamp) allow the UV protection panel to be stowed above the work area while the enclosure is in use.

**Light and blower switches** are located within easy reach of the operator. On models with UV light, a single 3-way switch powers the fluorescent and UV light, but only one at a time, helping to protect the operator from inadvertent UV exposure.

**Tempered safety glass sash** is sloped 10° for less glare and closer, more comfortable viewing. The glass is UV opaque and resistant to UV irradiation. May be pivoted upward and locked open for loading and cleaning.

**Glare-free fluorescent lighting.** The lamp is located above the work area, out of contact with the filtered air.

**Accessory Solid Epoxy Dished Work Surface.** Sold separately. See page 23 for ordering information.

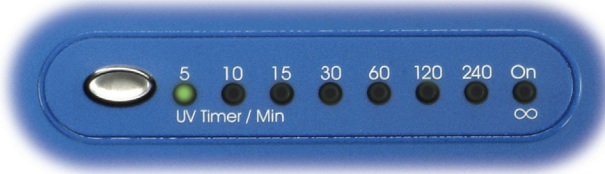

**Two convenient utility ports with iris openings** allow passage of tubing and electrical cords from equipment inside the enclosure through the back for connection to services. Plugs are provided to seal the ports when not in use.

**Ultraviolet lamp, 254 nm, with interlocked protection panel** (on models with UV lamp) provides secondary decontamination while the bench is not in use.

**Variable speed blower** with solid state control can be adjusted to extend filter life.

**Optional built-in Guardian™ Airflow Monitor** alerts the user to downflow velocities outside of preset range and HEPA filter conditions.



Exclusive feature

# PURIFIER® VERTICAL CLEAN BENCHES

## ORDERING INFORMATION

### Standard Features

- Vertical laminar flow
- Supply HEPA filter, 99.99% efficient at 0.3 microns
- ISO Class 5 air
- Disposable prefilter
- Nominal downflow velocity of 40-55 fpm
- Variable speed built-in blower with motorized impeller and solid state control
- Differential pressure gauge
- Air diffuser
- ☒ UV-resistant, glacier white and gray powder-coated aluminum and steel construction
- ☒ UV-opaque and resistant 1/4" thick tempered safety glass sash and sides
- Fluorescent lamp
- Light and blower switches
- ☒ 9.4" sash opening (11.6" for 6' models)
- Ergonomic 10° angled and hinged sash that pivots upward, locks to a loading height of 20" (30" for 6' models) and has wiping seals to promote ISO Class 5 conditions
- Two utility ports with iris openings and plugs
- UL Standard 61010-1 and CAN/CSA C22.2 conformity (115 volt models)
- CE Mark (230 volt models)
- One year warranty

### Standard Options

- ☒ Guardian Airflow Monitor that continuously monitors downflow airflow and has two LED lights to indicate when airflow is within or outside set point range.
- ☒ 254 nm UV lamp with 3-way switch (fluorescent, UV and off), interlocked protection panel that closes the sash opening to guard inadvertent exposure to UV rays; variable digital timer with eight settings in minutes of 5, 10, 15, 30, 60, 120, 240 and continuous

### Required Accessories

- Supporting work surface.
- Supporting base.

See page 23 for dimensional drawings.

☒ Exclusive feature



Purifier Vertical Clean Bench 3970200 on Solid Epoxy Dished Work Surface 3909900 and Telescoping Base Stand 3746710.

# PURIFIER® VERTICAL CLEAN BENCHES

## ORDERING INFORMATION

Catalog #	Nominal Width	Electrical Requirements	UV Lamp/ Panel/Timer	Airflow Monitor	Power Cord & Plug	Shipping Weight
3970200	2 feet	115 volts, 50/60 Hz, 5 amps			115 volts, 15 amps	165 lbs. (75 kg)
3970201	2 feet	115 volts, 50/60 Hz, 5 amps	•		115 volts, 15 amps	165 lbs. (75 kg)
3970203	2 feet	115 volts, 50/60 Hz, 5 amps		•	115 volts, 15 amps	165 lbs. (75 kg)
3970204	2 feet	115 volts, 50/60 Hz, 5 amps	•	•	115 volts, 15 amps	165 lbs. (75 kg)
3970220*	2 feet	230 volts, 50/60 Hz, 3 amps			230 volts, 10 amps, no plug	165 lbs. (75 kg)
3970221*	2 feet	230 volts, 50/60 Hz, 3 amps	•		230 volts, 10 amps, no plug	165 lbs. (75 kg)
3970223*	2 feet	230 volts, 50/60 Hz, 3 amps		•	230 volts, 10 amps, no plug	165 lbs. (75 kg)
3970224*	2 feet	230 volts, 50/60 Hz, 3 amps	•	•	230 volts, 10 amps, no plug	165 lbs. (75 kg)
3970300	3 feet	115 volts, 50/60 Hz, 5 amps			115 volts, 15 amps	205 lbs. (93 kg)
3970301	3 feet	115 volts, 50/60 Hz, 5 amps	•		115 volts, 15 amps	205 lbs. (93 kg)
3970303	3 feet	115 volts, 50/60 Hz, 5 amps		•	115 volts, 15 amps	205 lbs. (93 kg)
3970304	3 feet	115 volts, 50/60 Hz, 5 amps	•	•	115 volts, 15 amps	205 lbs. (93 kg)
3970320*	3 feet	230 volts, 50/60 Hz, 3 amps			230 volts, 10 amps, no plug	205 lbs. (93 kg)
3970321*	3 feet	230 volts, 50/60 Hz, 3 amps	•		230 volts, 10 amps, no plug	205 lbs. (93 kg)
3970323*	3 feet	230 volts, 50/60 Hz, 3 amps		•	230 volts, 10 amps, no plug	205 lbs. (93 kg)
3970324*	3 feet	230 volts, 50/60 Hz, 3 amps	•	•	230 volts, 10 amps, no plug	205 lbs. (93 kg)
3970400	4 feet	115 volts, 50/60 Hz, 5 amps			115 volts, 15 amps	245 lbs. (111 kg)
3970401	4 feet	115 volts, 50/60 Hz, 5 amps	•		115 volts, 15 amps	245 lbs. (111 kg)
3970403	4 feet	115 volts, 50/60 Hz, 5 amps		•	115 volts, 15 amps	245 lbs. (111 kg)
3970404	4 feet	115 volts, 50/60 Hz, 5 amps	•	•	115 volts, 15 amps	245 lbs. (111 kg)
3970420*	4 feet	230 volts, 50/60 Hz, 3 amps			230 volts, 10 amps, no plug	245 lbs. (111 kg)
3970421*	4 feet	230 volts, 50/60 Hz, 3 amps	•		230 volts, 10 amps, no plug	245 lbs. (111 kg)
3970423*	4 feet	230 volts, 50/60 Hz, 3 amps		•	230 volts, 10 amps, no plug	245 lbs. (111 kg)
3970424*	4 feet	230 volts, 50/60 Hz, 3 amps	•	•	230 volts, 10 amps, no plug	245 lbs. (111 kg)
3660600	6 feet	115 volts, 50/60 Hz, 5 amps			115 volts, 15 amps	393 lbs. (178 kg)
3660601	6 feet	115 volts, 50/60 Hz, 5 amps	•		115 volts, 15 amps	393 lbs. (178 kg)
3660603	6 feet	115 volts, 50/60 Hz, 5 amps		•	115 volts, 15 amps	393 lbs. (178 kg)
3660604	6 feet	115 volts, 50/60 Hz, 5 amps	•	•	115 volts, 15 amps	393 lbs. (178 kg)
3660620	6 feet	230 volts, 50/60 Hz, 3 amps			230 volts, 10 amps, no plug	393 lbs. (178 kg)
3660621	6 feet	230 volts, 50/60 Hz, 3 amps	•		230 volts, 10 amps, no plug	393 lbs. (178 kg)
3660623	6 feet	230 volts, 50/60 Hz, 3 amps		•	230 volts, 10 amps, no plug	393 lbs. (178 kg)
3660624	6 feet	230 volts, 50/60 Hz, 3 amps	•	•	230 volts, 10 amps, no plug	393 lbs. (178 kg)

\*International electrical configuration

# PURIFIER® FILTERED PCR ENCLOSURES

## INTRODUCTION

**Purifier Filtered PCR Enclosures are vertical clean benches that protect your work.** Available in 2', 3' and 4' widths, they provide a controlled environment in which to perform polymerase chain reaction experiments. ISO Class 5 air is constantly projected vertically down over the work area, minimizing the risk of cross contamination of samples.



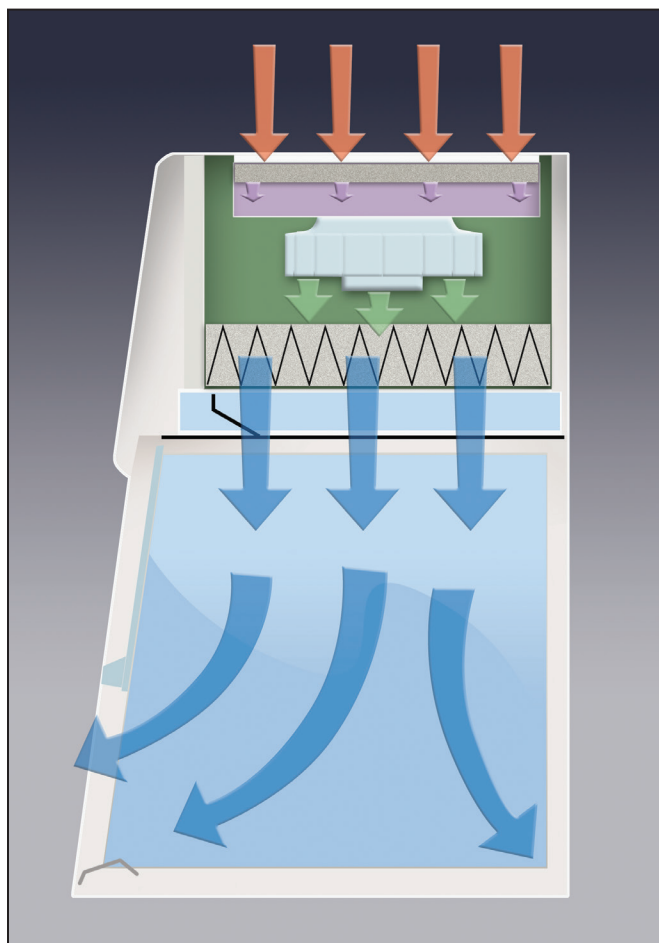

Purifier Filtered PCR Enclosures do not provide protection to the user and should not be used in conjunction with biohazardous material, toxins or radionuclides. You and your safety officer must carefully assess risks associated with any operation performed in the PCR enclosure.

The variable digital timer provides UV light exposure continuously or in user-selected increments of 5, 10, 15, 30, 60, 120 or 240 minutes to deactivate DNA and RNA contaminants. When the timer expires, the UV light automatically switches off in preparation for the next experiment. An interlocked protection panel guards against inadvertent exposure to UV rays.



*Purifier Filtered PCR Enclosure 3970305 on Solid Epoxy Dished Work Surface 3909901 and Telescoping Base Stand 3746711 with Ergonomic Chair 3744000 and Adjustable Footrest 3746000.*

*During operation, room air is drawn through a prefilter in the top of the cabinet to trap large particles. Then, the air flows through a 99.99% efficient HEPA filter and is projected vertically over the work area. This HEPA-filtered air prevents contaminants from entering the work area and provides a particulate-free work environment that minimizes cross contamination.*

-  Room Air
-  HEPA-Filtered Air
-  Unfiltered Air under Negative Pressure
-  Unfiltered Air under Positive Pressure

# PURIFIER® FILTERED PCR ENCLOSURES

## FEATURES & BENEFITS

**Particulate-free ISO 5 air.** Particle counts in the work area conform to ISO 14644-1 and 2.

**Ultraviolet lamp, 254 nm, with interlocked protection** denatures stray DNA strands and provides secondary decontamination while the enclosure is not in use. Two top-mounted support hooks allow the protection panel to be stowed above the work area while the bench is in use.

**Front-mounted differential pressure gauge** indicates the total system pressure across the HEPA filter and pressurized plenum to help determine HEPA filter loading.

**Two convenient utility ports with iris openings** allow passage of tubing and electrical cords from equipment inside the enclosure through the back for connection to services. Plugs are provided to seal the ports when not in use.

**HEPA filter** is rated to remove 99.99% of all particles 0.3 microns in size.

**Disposable prefilter** traps large particles to extend the life of the HEPA filter.

**Variable speed blower with solid state control** can be adjusted to extend filter life.

**Support hooks** allow the UV protection panel to be stowed above the work area while the enclosure is in use.

**Air diffuser** protects the HEPA filter from possible damage from direct contact with the operator and apparatus inside the enclosure. It distributes air evenly across the work area to optimize airflow.

**Glare-free fluorescent lighting.** The lamp is located above the work area, out of contact with the filtered air.

**Light and blower switches** are located within easy reach of the operator. The 3-way light switch powers the fluorescent and UV light, but only one at a time, helping to protect the operator from inadvertent UV exposure.

**Tempered safety glass sash** is sloped 10° for less glare and closer, more comfortable viewing than vertical sashes offer. The glass is UV opaque and resistant to UV irradiation. May be pivoted upward and locked open for loading and cleaning.

**Variable digital timer** provides timed UV light exposure. From the front-mounted control panel, the operator may select from eight settings in minutes of 5, 10, 15, 30, 60, 120, 240 and continuous.

**Protection panel interlocked with the UV lamp** closes off the sash opening to guard against inadvertent UV light exposure and prevent contaminants from entering when the enclosure is not in use.

**Accessory Solid Epoxy Dished Work Surface.** See page 23 for ordering information.

**Optional built-in Guardian™ Airflow Monitor** alerts the user to downflow velocities outside of preset range and HEPA filter conditions.

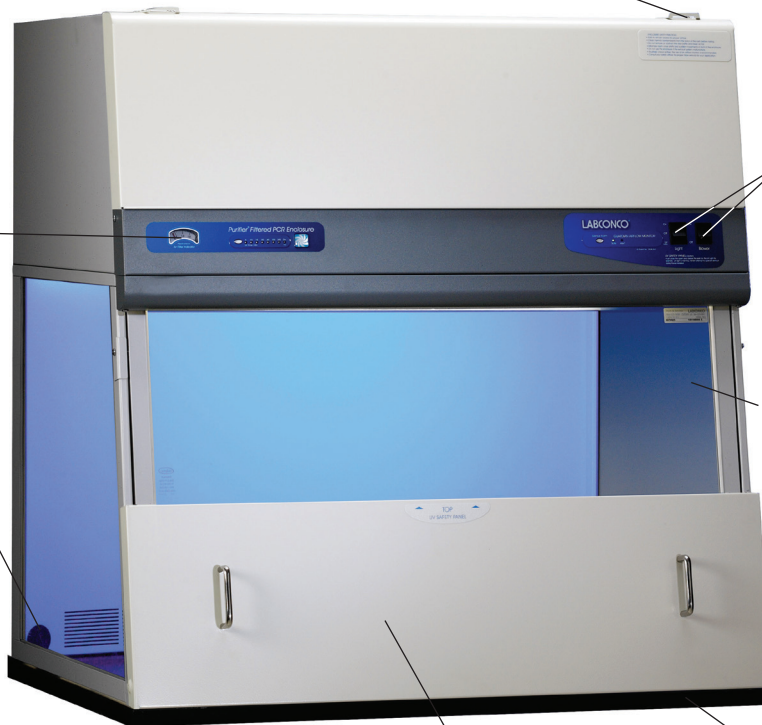

 Exclusive feature

# PURIFIER® FILTERED PCR ENCLOSURES

## ORDERING INFORMATION

### Standard Features

- Nominal downflow velocity of 40-55 fpm
- Supply HEPA filter, 99.99% efficient on particles 0.3 micron
- ISO Class 5 air
- Disposable prefilter
- Variable speed built-in blower with motorized impeller and solid state control rated for 5 amps
- Differential pressure gauge
- Air diffuser
- ☒ UV-resistant, glacier white and gray powder-coated aluminum and steel construction
- ☒ UV-opaque and resistant 1/4" thick tempered safety glass sash and sides
  - 9.4" high sash opening
  - Fluorescent lamp
  - 254 nm UV lamp
- ☒ Variable digital timer for UV exposure with eight settings in minutes of 5, 10, 15, 30, 60, 120, 240 and continuous
  - Blower and 3-way light (fluorescent, UV and off) switches
- ☒ Ergonomic 10° angled and hinged sash that pivots upward, locks to a loading height of 20" and has wiping seals to promote ISO Class 5 conditions
- ☒ Protection panel interlocked with UV lamp that closes the sash opening and two support hooks located atop the enclosure for stowing the panel
  - Two utility ports with iris openings and plugs
  - UL Standard 61010-1 and CAN/CSA C22.2 (115 volt models)
  - CE Mark (230 volt models)
  - One year warranty



Purifier Filtered PCR Enclosure 3970305 on Solid Epoxy Dished Work Surface 3909901 and Telescoping Base Stand 3746711.

### Standard Option

- ☒ Guardian Airflow Monitor that continuously monitors down-flow airflow and has two LED lights to indicate when airflow is within or outside set point range.

### Required Accessories

- Supporting work surface. Place on existing casework or see page 23.
- Supporting base. Place on existing casework or see pages 28-31.

See page 23 for dimensional drawings.

Catalog #	Nominal Width	Electrical Requirements	UV Lamp/Timer/Protection Panel	Airflow Monitor	Power Cord & Plug	Shipping Weight
3970202	2 feet	115 volts, 50/60 Hz, 5 amps	•		115 volts, 15 amps	165 lbs. (75 kg)
3970205	2 feet	115 volts, 50/60 Hz, 5 amps	•	•	115 volts, 15 amps	165 lbs. (75 kg)
3970222*	2 feet	230 volts, 50/60 Hz, 3 amps	•		230 volts, 10 amps, no plug	165 lbs. (75 kg)
3970225*	2 feet	230 volts, 50/60 Hz, 3 amps	•	•	230 volts, 10 amps, no plug	165 lbs. (75 kg)
3970302	3 feet	115 volts, 50/60 Hz, 5 amps	•		115 volts, 15 amps	205 lbs. (93 kg)
3970305	3 feet	115 volts, 50/60 Hz, 5 amps	•	•	115 volts, 15 amps	205 lbs. (93 kg)
3970322*	3 feet	230 volts, 50/60 Hz, 3 amps	•		230 volts, 10 amps, no plug	205 lbs. (93 kg)
3970325*	3 feet	230 volts, 50/60 Hz, 3 amps	•	•	230 volts, 10 amps, no plug	205 lbs. (93 kg)
3970402	4 feet	115 volts, 50/60 Hz, 5 amps	•		115 volts, 15 amps	245 lbs. (111 kg)
3970405	4 feet	115 volts, 50/60 Hz, 5 amps	•	•	115 volts, 15 amps	245 lbs. (111 kg)
3970422*	4 feet	230 volts, 50/60 Hz, 3 amps	•		230 volts, 10 amps, no plug	245 lbs. (111 kg)
3970425*	4 feet	230 volts, 50/60 Hz, 3 amps	•	•	230 volts, 10 amps, no plug	245 lbs. (111 kg)

\*International electrical configuration

☒ Exclusive feature

# PURIFIER® VERTICAL CLEAN BENCHES & FILTERED PCR ENCLOSURES

## DIMENSIONS & ACCESSORIES

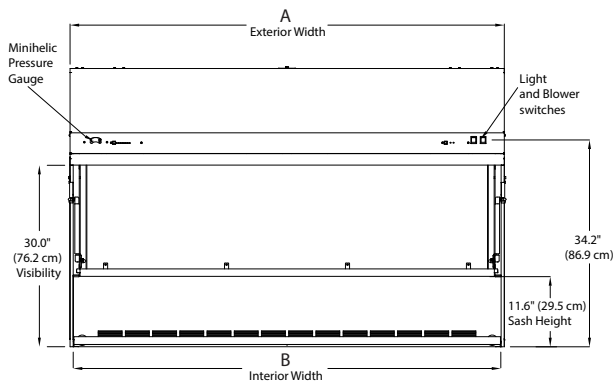

FRONT (6' Models)

### Purifier Vertical Clean Benches & Filtered PCR Enclosures

	2-Foot	3-Foot	4-Foot	6-Foot
<b>A</b>	24.0" (61.0 cm)	36.0" (91.4 cm)	48.0" (121.9 cm)	72.0" (182.9 cm)
<b>B</b>	22.8" (57.9 cm)	34.8" (88.4 cm)	46.8" (118.9 cm)	70.8" (179.8 cm)

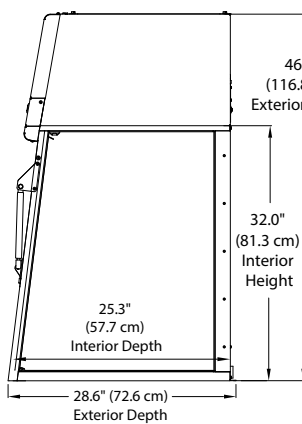

SIDE (6' Models)

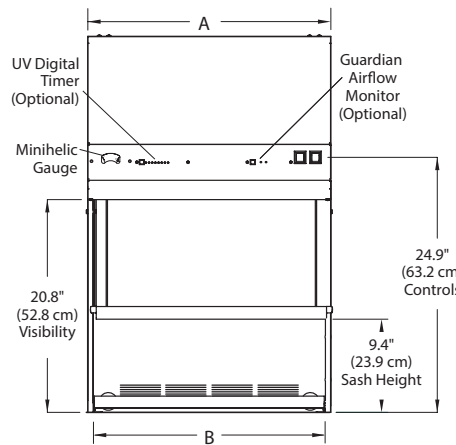

FRONT (2' - 4' Models)

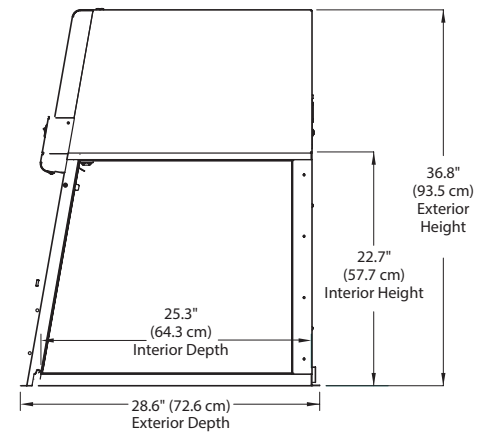

SIDE (2' - 4' Models)

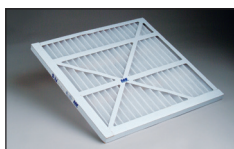

#### Replacement Disposable Prefilters

Corrugated paper prefilters trap large particles to extend HEPA filter life. Labconco recommends replacing the prefilter every three months. One each.

Catalog #	For use with	Shipping Weight
3935700	2-Ft Vertical Clean Bench	1.0 lb. (0.5 kg)
3935701	3-Ft Vertical Clean Bench	1.0 lb. (0.5 kg)
3935702	4-Ft Vertical Clean Bench	1.0 lb. (0.5 kg)
3935701	6-Ft Vertical Clean Bench*	1.0 lb. (0.5 kg)

\*Two required



#### Solid Epoxy Dished Work Surfaces

Black chemical-resistant work surface is contoured to fit the dimensions of the Purifier Vertical Clean Benches and Filtered PCR Enclosures and to contain spills.

Catalog #	For use with	Dimensions	Shipping Weight
3909900	2-Ft Purifier Enclosure	24.0" w x 29.0" d x 1.0" h (61 cm x 73.7 cm x 2.5 cm)	50.0 lbs. (23 kg)
3909901	3-Ft Purifier Enclosure	36.0" w x 29.0" d x 1.0" h (91.4 cm x 73.7 cm x 2.5 cm)	75.0 lbs. (34 kg)
3909902	4-Ft Purifier Enclosure	48.0" w x 29.0" d x 1.0" h (122 cm x 73.7 cm x 2.5 cm)	100.0 lbs. (45 kg)
3909910	6-Ft Purifier Enclosure	72.0" w x 29.0" d x 1.0" h (182.8 cm x 73.7 cm x 2.5 cm)	150.0 lbs. (68 kg)



#### IV Bars

Support intravenous solution bottles and bags. Include IV bar, mounting hardware, four hangers and installation instructions.

Catalog #	For use with	Shipping Weight
3721000	2-Ft Vertical Clean Bench	4.0 lbs. (1.8 kg)
3721001	3-Ft Vertical Clean Bench	6.0 lbs. (2.7 kg)
3721002	4-Ft Vertical Clean Bench	8.0 lbs. (3.6 kg)
3721004	6-Ft Vertical Clean Bench	10.0 lbs. (4.5 kg)

Please contact Labconco for ordering information on stainless steel work surfaces.

# PURIFIER® NON-VENTILATED PCR ENCLOSURES

## FEATURES & BENEFITS

**Purifier Non-Ventilated PCR Enclosures provide a circulation-free work area designed to reduce cross contamination.** These enclosures have an ultraviolet light that decontaminates surfaces and denatures trace DNA during periods of non-use. A protection panel interlocked with the UV light closes the sash opening while the UV light is in use to prevent inadvertent personnel exposure and contaminants from entering the enclosure.

The Purifier Non-Ventilated PCR Enclosures, designed for conducting polymerase chain reaction procedures, include a UV light timer that allows the user to select from eight time settings. Because these enclosures do not provide protection to the user, they should not be used in conjunction with biohazardous material, toxins or radionuclides. You and your safety officer must carefully assess the risk associated with any operation performed in a Purifier Non-Ventilated Enclosure.

**Glare-free fluorescent lighting** provides illumination inside the enclosure.

**The 254 nm ultraviolet lamp** eliminates stray DNA and provides secondary decontamination while the enclosure is not in use.

**Electrical receptacle** located inside the enclosure is powered by the front-mounted auxiliary switch.

**Light and auxiliary electrical receptacle switches** are located within easy reach of the operator. The 3-way light switch powers the fluorescent and UV light, but only one at a time, helping to protect the operator from inadvertent UV exposure.

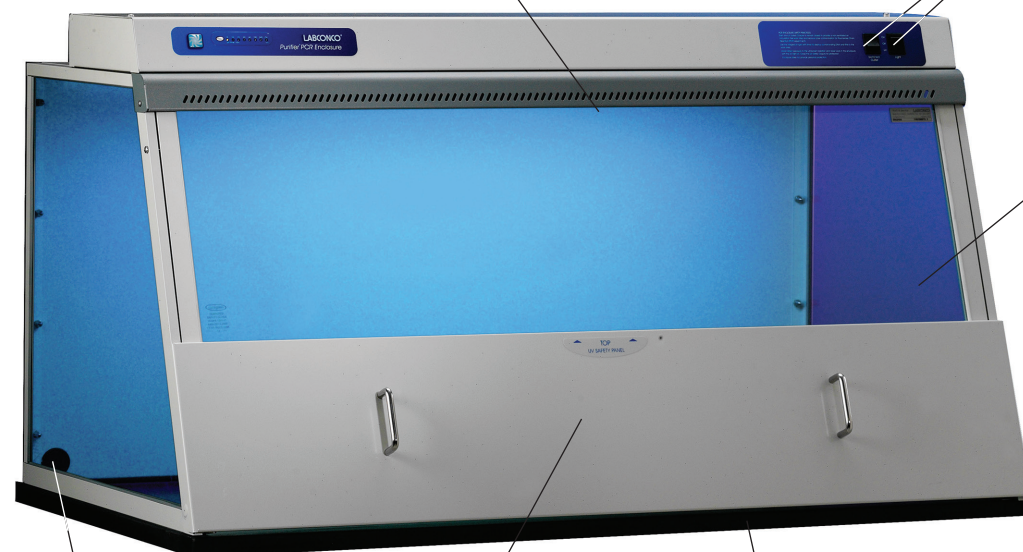

**Two convenient utility ports with iris openings** allow passage of tubing and electrical cords from equipment inside the enclosure through the back for connection to services. Plugs are provided to seal the ports when not in use.

**Protection panel interlocked with the UV light** closes off the sash opening while the UV light is on and prevents contaminants from entering when the enclosure is not in use.

**Accessory Solid Epoxy Dished Work Surface.** See page 26 for ordering information.

**Tempered safety glass sash** is sloped 20° for less glare and closer, more comfortable viewing than vertical sashes offer. The glass is UV opaque and resistant to UV irradiation. Wiping seals reduce cross contamination inside the enclosure. The sash has a spring-loaded latch so that it may be pivoted upward and locked open for loading and cleaning.

**Variable digital timer** provides timed UV light exposure. From the front-mounted control panel, the operator may select from eight settings in minutes of 5, 10, 15, 30, 60, 120, 240 and continuous.

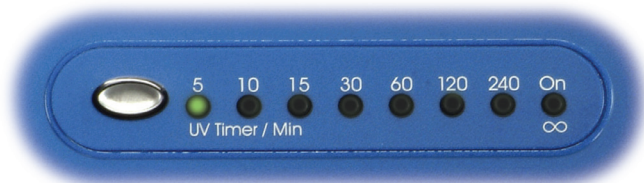





 Exclusive feature



# PURIFIER® NON-VENTILATED PCR ENCLOSURES

## ORDERING INFORMATION

### Standard Features

-  UV-resistant, glacier white and gray powder-coated aluminum and steel construction
-  UV-opaque and resistant, 1/4" thick tempered safety glass sash and sides
  - 7.8" high sash opening
-  Ergonomic 20° angled and hinged sash that pivots upward, locks to a loading height of 20" and has wiping seals to reduce cross contamination
-  Protection panel with UV light interlock to close the sash opening
  - Fluorescent lamp
  - 254 nm UV lamp
  - Interior electrical receptacle
-  Variable digital timer for UV exposure with eight settings in minutes of 5, 10, 15, 30, 60, 120, 240 and continuous
  - Front-mounted switches for 3-way light (fluorescent, UV and off) and auxiliary electrical receptacle
  - Two utility ports with iris openings and plugs
  - UL 61010-1 and CAN/CSA C22.2 conformity (115 volt models)
  - CE Conformity Marking (230 volt models)
  - One year warranty

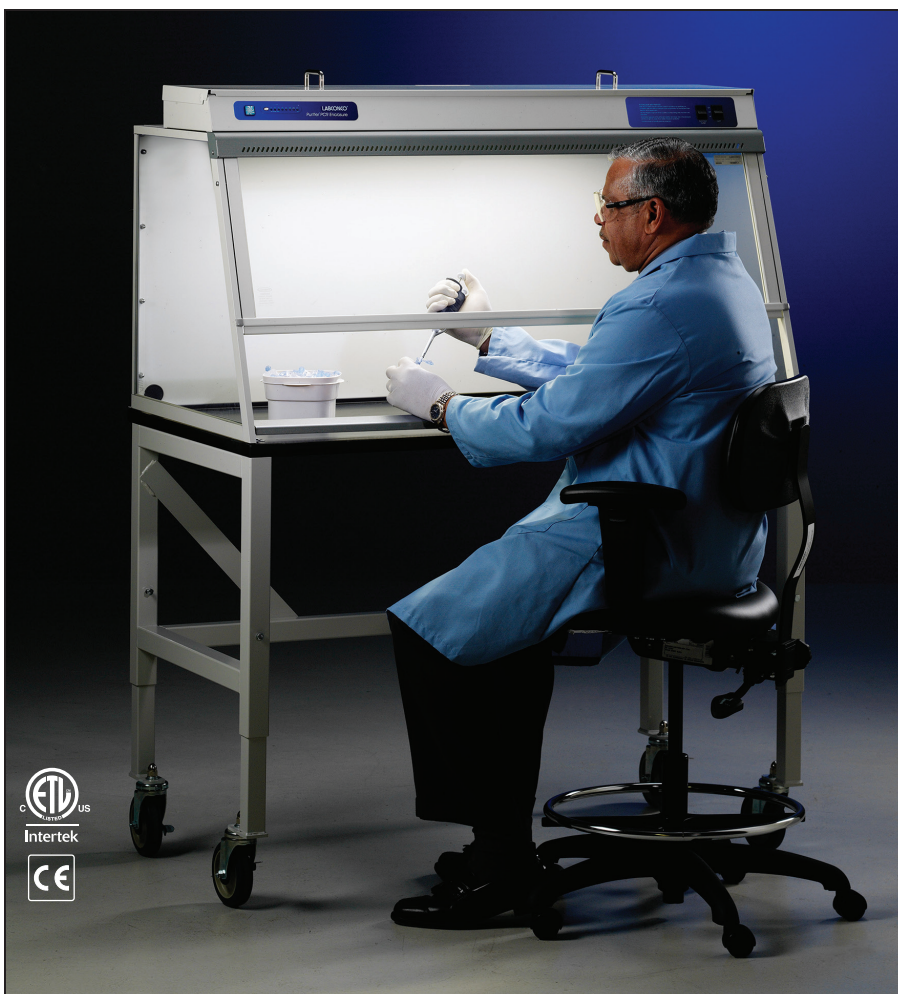

Purifier Non-Ventilated PCR Enclosure 3952400 on Solid Epoxy Dished Work Surface 3908402 and Telescoping Base Stand 3747012 with Ergonomic Chair 3744000 and Adjustable Footrest 3746000.



### Required Accessories

- Supporting work surface. Place on existing casework or see page 26.
- Supporting base. Place on existing casework or see pages 28-29.

See page 26 for dimensional drawings.

Catalog #	Nominal Width	Electrical Requirements	Variable Timed UV Lamp/Protection Panel	Power Cord & Plug	Shipping Weight
3952400	4 feet	115 volts, 60 Hz, 10 amps	•	115 volts, 15 amps	175 lbs. (79 kg)
3952420*	4 feet	230 volts, 50 Hz, 5 amps	•	230 volts, 10 amps, no plug	175 lbs. (79 kg)

\*International electrical configuration

# PURIFIER® NON-VENTILATED PCR ENCLOSURES

## DIMENSIONS & ACCESSORIES

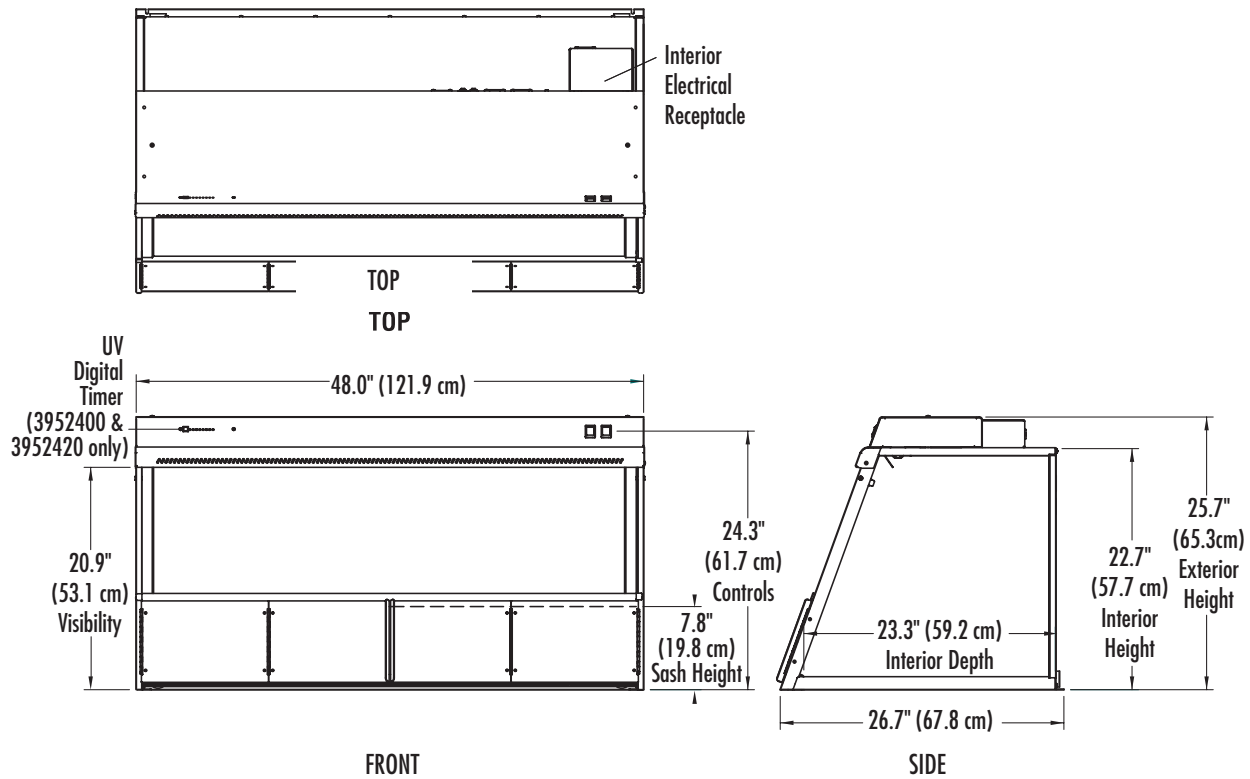

### Telescoping Base Stands

Powder-coated steel. Adjust in 1" increments from 27.5" to 33.5" high. Available with fixed leveling feet or casters. See pages 28-29 for more information.



### Solid Epoxy Dished Work Surface

Black chemical-resistant work surface is contoured to fit the dimensions of the Purifier Non-Ventilated PCR Enclosure and Tissue Culture Enclosure and to contain spills.



### 3744000 Ergonomic Chair with Armrests

Chair has 6-way articulating seat and back control for personalized adjustment. Pneumatic mechanism adjusts seat height from 18.25" to 25.75". Shipping weight 43.0 lbs. (19.5 kg). **⚠WARNING:** Cancer - P65Warnings.ca.gov (California only)



### 3746000 Adjustable Footrest

Elevates feet and permits angle repositioning while in use. 18.5" w x 11.5" d x 8" high. Shipping weight 6.0 lbs. (2.7 kg)

Catalog #	For use with	Dimensions	Shipping Weight
3908402	Non-Ventilated PCR & Tissue Culture Enclosures	48.0" w x 26.7" d x 1.0" h (122 cm x 67.8 cm x 2.5 cm)	96 lbs. (44 kg)

## ACCESSORIES



### Coated Steel Blowers for Canopy-Ducted Purifier Class I and HEPA Filtered Enclosures

A remote blower or house exhaust is required when canopy-ducting the Purifier Class I Safety Enclosure or Purifier HEPA Filtered Enclosure. Phenolic-coated impeller and housing, powder-coated steel

base and weather cover, belt-drive motor with adjustable sheave and self-adjusting gravity belt tightener, flow-through vent holes and louvers, lubricated pillow block bearings, and variable exhaust orientation (vertical discharge is recommended). Blower inlet is 10.87" OD and is sized to accept 10" nominal diameter PVC duct. Blower outlet is 5.5" d x 10.0" w. Contact Labconco for ordering information on Remote Blowers with other equivalent duct lengths or diameters or other electrical configurations.

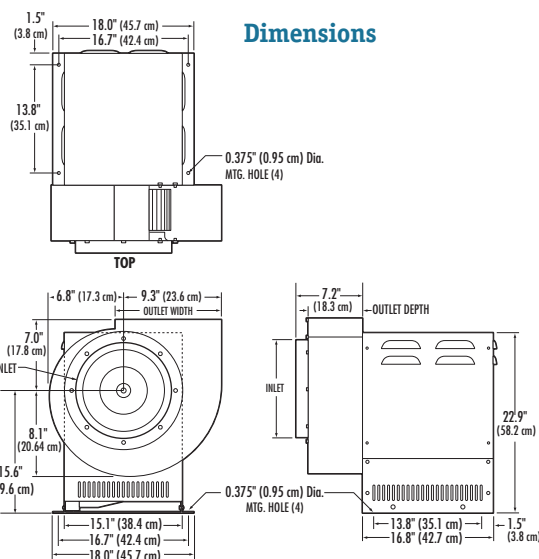

Catalog #	For use with:	Electrical Requirements	HP	.12* CFM@RPM	.25* CFM@RPM	.38* CFM@RPM	.50* CFM@RPM	.62* CFM@RPM	.75* CFM@RPM	Shipping Weight
7068000	Canopy-ducted 2-Ft & 3-Ft Purifier Class I & HEPA Filtered Enclosures with up to 100 equivalent feet of 6" dia. duct	115 volts, 60 Hz, 4.0 amps	1/6	370 @ 530 500 @ 650	300 @ 635 540 @ 800	308 @ 760 410 @ 800	—	—	—	92 lbs. (41.7 kg)
7068200	Canopy-Ducted 4-Ft Purifier Class I & HEPA Filtered Enclosures with up to 100 equivalent feet of 6" dia. duct	115 volts, 60 Hz, 4.4 amps	1/4	—	540 @ 800 720 @ 950	410 @ 800 760 @ 1050	350 @ 870 710 @ 1060	390 @ 970 620 @ 1060	430 @ 1060	92 lbs. (41.7 kg)

\*Static pressure in inches H<sub>2</sub>O

## ERGONOMIC CHAIR



The Ergonomic Chair provides comfortable seating and may be used throughout the laboratory.

### Standard Features

- 6-way articulating seat and back control for personalized adjustment.
- Pneumatic mechanism seat height adjustment from 18.25" to 25.75".
- Five-leg black reinforced composite base with 2" diameter ball-bearing casters.
- Aluminum support ring.
- Removable armrests.
- Black vinyl upholstery.

Catalog #	Description	Shipping Weight
3744000	Ergonomic Chair with Armrests <b>⚠WARNING:</b> Cancer - P65Warnings.ca.gov (California only)	43.0 lbs. (19.5 kg)

# TELESCOPING BASE STANDS

These stands have telescoping legs so that they may be adjusted to eight height positions.\* The stands are available with fixed feet or casters for mobility.

## Standard Features

- Support any Purifier Clean Bench or Enclosure.
- Models with fixed feet support loads up to 4,000 pounds (1814 kg). Models with casters support load up to 1,000 pounds (454 kg).
- Durable 1.75" tubular, powder-coated steel frame. Models 3' wide and larger have rear crossbar supports.
- Telescoping legs are adjustable to eight height positions in 1" increments from 27.5" to 34.5".\*
- Available with fixed leveling feet or 5" diameter, toe-locking, non-marking polyurethane casters with bearings for quiet operation.
- ADA-compliant.

## 3730500 Caster Kit

For converting Telescoping Base Stands with Fixed Feet. Kit includes four 5" diameter, non-marking polyurethane casters with bearings and toe locks. Load rating for each caster is 250 pounds. **Installation is required.** Shipping weight 10 lbs. (5 kg)



Top to Bottom:

Telescoping Base Stand with Fixed Feet 3746702.

Telescoping Base Stand with Casters 3746710.

Telescoping Base Stand with Fixed Feet 3888700.

## With Fixed Feet

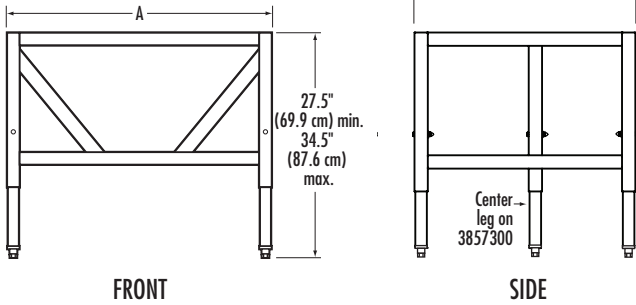

## With Casters

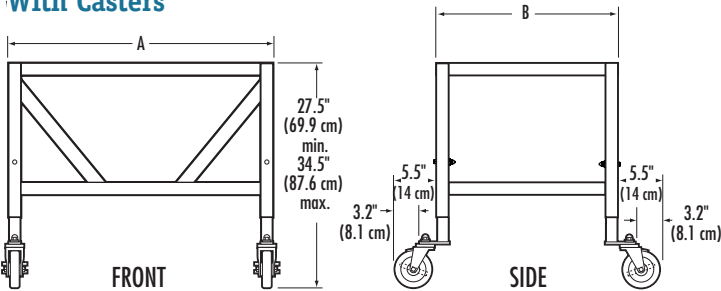

Catalog Numbers	Nominal Width	A	B
3746700, 3746710	2-Ft	24.0" (60.0 cm)	29.0" (73.7 cm)
3746701, 3746711	3-Ft	36.0" (91.4 cm)	29.0" (73.7 cm)
3613200, 3613201	3-Ft	35.0" (88.9 cm)	29.0" (73.7 cm)
3747002, 3747012	4-Ft	48.0" (121.9 cm)	25.5" (64.8 cm)
3746702, 3746712	4-Ft	48.0" (121.9 cm)	29.0" (73.7 cm)
3888700, 3888701	4-Ft	47.0" (119.4 cm)	29.0" (73.7 cm)
3255000, 3255001	5-Ft	59.0" (149.9 cm)	29.0" (73.7 cm)
3857700, 3857701	6-Ft	71.0" (180.3 cm)	29.0" (73.7 cm)
3857300, 3857301	8-Ft	96.0" (243.8 cm)	29.0" (73.7 cm)

# TELESCOPING BASE STANDS

## Base Stands for Horizontal Clean Benches

Nominal Width	Catalog #	Overall Width x Depth	Shipping Weight	Casters
3-Ft	3613200	35.0" w x 29.0" d (88.9 x 73.7 cm)	100 lbs. (45 kg)	
3-Ft	3613201	35.0" w x 29.0" d (88.9 x 73.7 cm)	100 lbs. (45 kg)	•
4-Ft	3888700	47.0" w x 29.0" d (119.4 x 73.7 cm)	120 lbs. (55 kg)	
4-Ft	3888701	48.0" w x 29.0" d (121.9 x 73.7 cm)	120 lbs. (55 kg)	•
5-Ft	3255000	59.0" w x 29.0" d (149.9 x 73.7 cm)	130 lbs. (59 kg)	
5-Ft	3255001	59.0" w x 29.0" d (149.9 x 73.7 cm)	130 lbs. (59 kg)	•
6-Ft	3857700	71.0" w x 29.0" d (180.3 x 73.7 cm)	135 lbs. (61 kg)	
6-Ft	3857701	72.0" w x 29.0" d (182.9 x 73.7 cm)	135 lbs. (61 kg)	•
8-Ft	3857300	96.0" w x 29.0" d (243.8 x 73.7 cm)	165 lbs. (75 kg)	
8-Ft	3857301	96.0" w x 29.0" d (243.8 x 73.7 cm)	165 lbs. (75 kg)	•

## Base Stands for Class I & HEPA Filtered Enclosures, Vertical Clean Benches & PCR Enclosures, & Non-Filtered Enclosures

Nominal Width	Catalog #	Overall Width x Depth	Shipping Weight	Casters
2-Ft	3746700	24.0" w x 29.0" d (61.0 x 73.7 cm)	80 lbs. (36 kg)	
2-Ft	3746710	24.0" w x 29.0" d (61.0 x 73.7 cm)	85 lbs. (39 kg)	•
3-Ft	3746701	36.0" w x 29.0" d (91.4 x 73.7 cm)	105 lbs. (48 kg)	
3-Ft	3746711	36.0" w x 29.0" d (91.4 x 73.7 cm)	110 lbs. (50 kg)	•
4-Ft	3746702	48.0" w x 29.0" d (121.9 x 73.7 cm)	115 lbs. (52 kg)	
4-Ft	3746712	48.0" w x 29.0" d (121.9 x 73.7 cm)	120 lbs. (55 kg)	•
4-Ft	3747002*	48.0" w x 25.5" d (121.9 x 64.8 cm)	110 lbs. (50 kg)	
4-Ft	3747012*	48.0" w x 25.5" d (121.9 x 64.8 cm)	115 lbs. (52 kg)	•
6-Ft	3746704	72.0" w x 29.0" d (92.8 cm x 73.7 cm)	125 lbs. (57 kg)	
6-Ft	3746714	72.0" w x 29.0" d (92.8 cm x 73.7 cm)	130 lbs. (59 kg)	•

\*For Non-Filtered PCR Enclosures

### Accessory Shelves

Glacier white, powder-coated, 16 gauge steel. Designed to hook on the lower rear horizontal cross member of the Telescoping Base Stand. Provides storage space for wipes, cleaning agents, gloves and other miscellaneous laboratory apparatus. One each.



Nominal Width	Catalog #	Shelf Width x Depth	Shipping Weight	For Use With:
2-Ft	3811100	20.4" x 9.9" (51.8 x 25.1 cm)	9 lbs. (4 kg)	3746700, 3746710
3-Ft	3811101	32.4" x 9.9" (82.3 x 25.1 cm)	12 lbs. (5 kg)	3746701, 3746711
4-Ft	3811102	44.4" x 9.9" (112.8 x 25.1 cm)	15 lbs. (7 kg)	3747002, 3746702, 3747012, 3746712
5-Ft	3811103	56.4" x 9.9" (143.3 x 25.1 cm)	19 lbs. (9 kg)	3255000, 3255001
6-Ft	3811104	68.4" x 9.9" (173.7 x 25.1 cm)	23 lbs. (10 kg)	3746704, 3746714

# ELECTRIC & MANUAL HYDRAULIC LIFT BASE STANDS

These stands have a built-in hydraulic lift so that height may be adjusted at any time. They allow you to position the stand and the safety enclosure or clean bench it supports to accommodate persons wheelchair bound or of different heights, to transport equipment through doorways, and for easier service access.

## Standard Features

- Support Purifier Class I Safety Enclosures, Purifier HEPA Filtered Enclosures, Purifier Vertical & Horizontal Clean Benches and Purifier Filtered PCR Enclosures.
- Support loads up to 1,000 pounds (454 kg).
- Durable 1.75" tubular, powder-coated steel frame with rear crossbar supports. Sub-frame is 2.0" x 3.0".
- Height is infinitely adjustable from 25.5" to 33.5" high.
- Include four powder-coated, die-cast feet with levelers.
- Include front-accessible up/down switch (Electric Lift models)
- Include front-accessible hand crank. Turning the crank clockwise raises the stand; counterclockwise lowers it. The handle may be disengaged and folded under, out of the way, when not in use. (Manual Lift models)
- ADA-compliant.



Manual Hydraulic Lift Base Stand 3780304.



## Caster Kit 3784000

Castors add mobility to the Hydraulic Lift Base Stand. Kit includes four 5" diameter, non-marking polyurethane casters with toe locks. Load rating for each caster is 250 pounds. Casters have bearings for quiet operation. Casters replace the fixed feet that are included with the stand. **Installation is required.** Not for use with stands that support hard-ducted enclosures. 10 lbs. (5 kg)

## Hydraulic Stand Brace

Required with Horizontal Clean Benches placed onto Electric or Manual Hydraulic base stands.

Catalog Numbers	Width	Shipping Weight
3257000	3'	10.0 lbs (4.5 kg)
3257001	4'	14.0 lbs (6.4 kg)
3257002	5'	18.0 lbs (8.2 kg)
3257003	6'	22.0 lbs (10.0 kg)

## Electric Lift

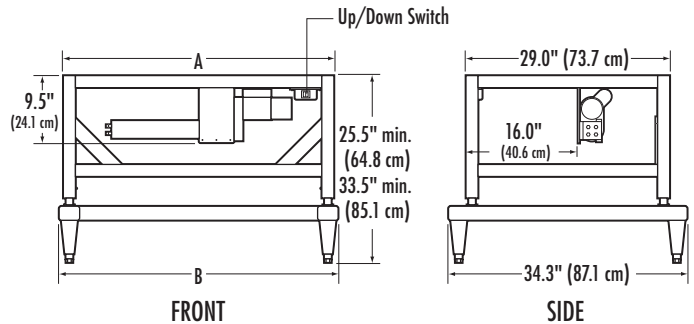

## Manual Lift

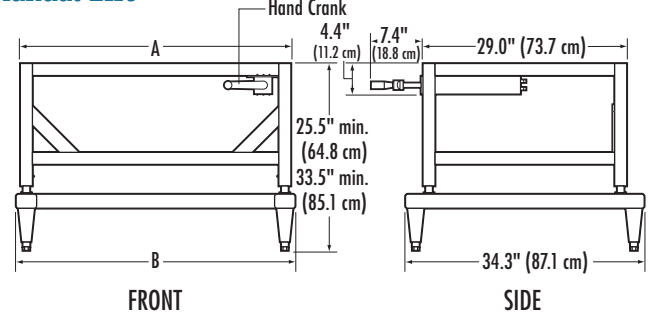

Nominal Width	A	B
3-Ft	36.0" (91.4 cm)	37.2" (94.5 cm)
4-Ft	48.0" (121.9 cm)	49.2" (125.0 cm)
5-Ft	60.0" (152.4 cm)	61.2" (155.5 cm)
6-Ft	72.0" (182.9 cm)	73.2" (185.9 cm)

# ELECTRIC & MANUAL HYDRAULIC LIFT BASE STANDS

## Electric Hydraulic Lift Base Stands

Nominal Width	Overall Catalog #	Switch Width x Depth	Raise/Lower Location	Electrical Requirements	Weight
3-Ft	<b>3780300</b>	36.0" w x 29.0" d (91.4 x 73.7 cm)	Right Side	115 volts, 60 Hz, 2.4 amps	150 lbs. (68 kg)
3-Ft	<b>3780303*</b>	36.0" w x 29.0" d (91.4 x 73.7 cm)	Right Side	230 volts, 50/60 Hz, 0.8 amp	150 lbs. (68 kg)
4-Ft	<b>3780301</b>	48.0" w x 29.0" d (121.9 x 73.7 cm)	Right Side	115 volts, 60 Hz, 2.4 amps	180 lbs. (82 kg)
4-Ft	<b>3780304*</b>	48.0" w x 29.0" d (121.9 x 73.7 cm)	Right Side	230 volts, 50/60 Hz, 0.8 amp	180 lbs. (82 kg)
5-Ft	<b>3780306</b>	60.0" w x 29.0" d (152.4 x 73.7 cm)	Right Side	115 volts, 60 Hz, 2.4 amps	210 lbs. (95 kg)
5-Ft	<b>3780307*</b>	60.0" w x 29.0" d (152.4 x 73.7 cm)	Right Side	230 volts, 50/60 Hz, 0.8 amps	210 lbs. (95 kg)
6-Ft	<b>3780302</b>	72.0" w x 29.0" d (182.8 x 73.7 cm)	Right Side	115 volts, 60 Hz, 2.4 amps	240 lbs. (109 kg)
6-Ft	<b>3780305*</b>	72.0" w x 29.0" d (182.8 x 73.7 cm)	Right Side	230 volts, 50/60 Hz, 0.8 amps	109 lbs. (109 kg)

\*International electrical configuration

## Manual Hydraulic Lift Base Stands

Nominal Width	Catalog #	Overall Width x Depth	Raise/Lower Location	Shipping Weight
3-Ft	<b>3780400</b>	36.0" w x 29.0" d (91.4 x 73.7 cm)	Right Side	150 lbs. (68 kg)
4-Ft	<b>3780401</b>	48.0" w x 29.0" d (121.9 x 73.7 cm)	Right Side	180 lbs. (82 kg)
5-Ft	<b>3780403</b>	60.0" w x 29.0" d (121.9 x 73.7 cm)	Right Side	210 lbs. (95 kg)
6-Ft	<b>3780402</b>	72.0" w x 29.0" d (182.8 x 73.7 cm)	Right Side	240 lbs. (108.9 kg)

*Contact Labconco for more information about these quality products for your laboratory.*



Biological Safety Cabinets



Laboratory Animal Research Stations



Fume Hoods & Carbon-Filtered Enclosures



Balance & Bulk Powder Enclosures



Glove Boxes



Glassware Washers



Water Purification Systems



Freeze Dry Systems



Vacuum Concentrators & Cold Traps

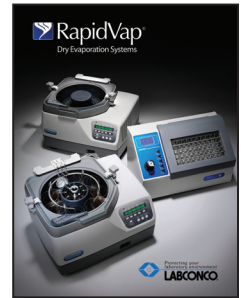

Multiple Sample Evaporation Systems



Agricultural Chemistry Products



Laboratory Carts & Benches



Blood Drawing Chairs



Forensic Enclosures



**Labconco Corporation**

8811 Prospect Avenue  
 Kansas City, MO 64132-2696  
 816-333-8811 or 800-821-5525  
 FAX: 816-363-0130  
 HOME PAGE: Labconco.com



© 2022 by Labconco Corporation  
 Printed in the U.S.A.  
 Product design subject to change without notice  
 2-12-5/09/22